

CARBON STEEL GATE VALVE FLANGED CLASS 300 PN50 TRIM8

Carbon steel gate valve TRIM8 flanged Class 300 PN50 full bore for water distribution, gas oil, steam, petrochemical, petroleum industry and gas.

Rising non rotating stem with flexible one piece wedge.

Graphite packing for stem and gasket bonnet in stainless steel+graphite.

Gate valve with fire safe certificate API 6FA to reduce risks in case of fire.

Compatible with explosive atmosphere, ATEX Zone 1&21 and Zone 2&22.



Size : DN50 à DN400 (NPS 2" to 16")

Connection : Flanges RF Class 300 PN50

Min Temperature : -29°C

Max Temperature : +425°C

Max Pressure : 50 Bars

Specifications : Rising non rotating stem

Bolted bonnet and packing

Full bore, Fire safe API 6FA

Materials : Carbon steel ASTM A216 WCB

CARBON STEEL GATE VALVE FLANGED CLASS 300 PN50 TRIM8

SPECIFICATIONS :

- Full bore
- Fire safe API 6FA
- Rising, non-rotating stem
- Fixed non rising handwheel
- Flexible one piece wedge
- Flanges R.F. Class 300 (PN50)
- Carbon steel body
- Bolted bonnet and gland pack
- ½ stellite (Trim 8 , seat with stellite)
- Acrylic grey painting RAL 7001 color, 60 µm thickness

USE :

- Water distribution, gas oil, steam, petrochemical, petroleum industry, gas
- Min and max Temperature Ts : - 29°C to + 425°C
- Max Pressure Ps : 50 bars
- **Do not use with scraper**
- **Tighten the gland packing in service**

FLOW COEFFICIENT Kvs :

DN (mm)	50	80	100	150	200	250	300	350	400
NPS (")	2"	3"	4"	6"	8"	10"	12"	14"	16"
Kvs	265	614	1124	2690	4940	7720	11540	14070	18650

TORQUE VALUE (in Nm without safety coefficient) :

DN	50	80	100	150	200	250	300	350	400
NPS (")	2"	3"	4"	6"	8"	10"	12"	14"	16"
Torque (Nm)	70	124	160	220	300	480	520	1075	1446

GEARBOX SPECIFICATIONS :

DN	400
NPS (")	16"
Input Torque (Nm)	130

NUMBER OF CYCLES TO CLOSE OR OPEN THE VALVE :

DN	50	80	100	150	200	250	300	350	400
NPS (")	2"	3"	4"	6"	8"	10"	12"	14"	16"
Number of cycles	15	29	23	28	36	45	54	46	52

CARBON STEEL GATE VALVE FLANGED CLASS 300 PN50 TRIM8

PRESSURE / TEMPERATURE RELATION :

(According to AMSE B16-34 for A216 WCB)

Pressure (Bar)	51.1	51.1	46.2	45.1	43.8	41.3	37.9	36.9	36.9	34.8	28.2
Temperature (°C)	-29	38	93	149	204	260	316	343	371	399	425

PRESSURE / TEMPERATURE GRAPH :

Pressure

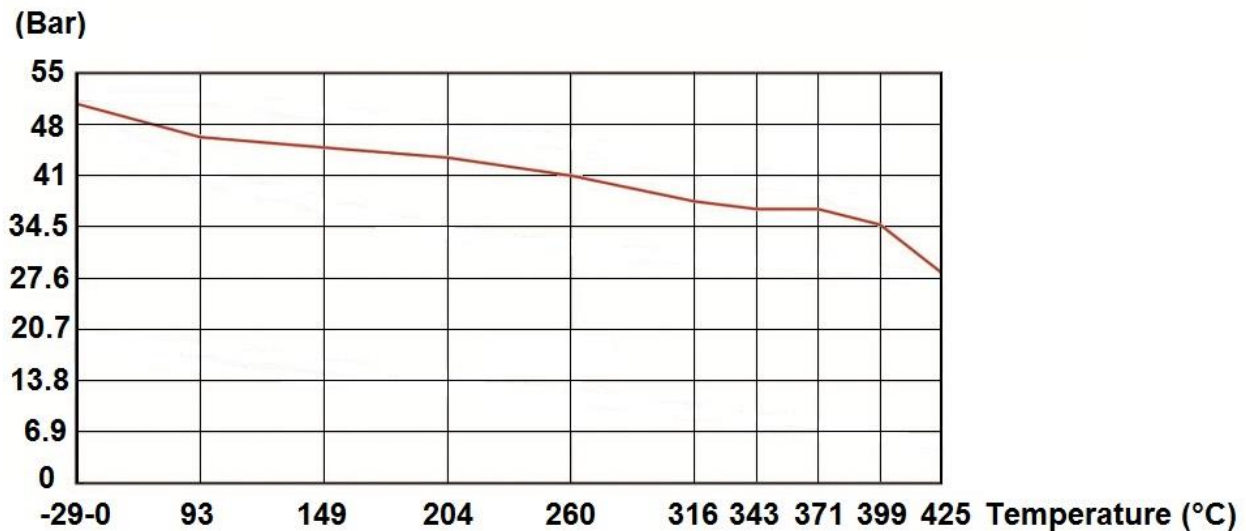

RANGE :

- Carbon steel gate valve with flanges R.F. Class 300 (PN50) **Ref. 144** From DN 50 to DN 350 (from NPS 2" to 14")
- Carbon steel gate valve with flanges R.F. Class 300 (PN50) with gearbox **Ref. 144** DN 400 (NPS 16")

CARBON STEEL GATE VALVE FLANGED CLASS 300 PN50 TRIM8

MATERIALS DN50-350 (NPS 2" to 14") :

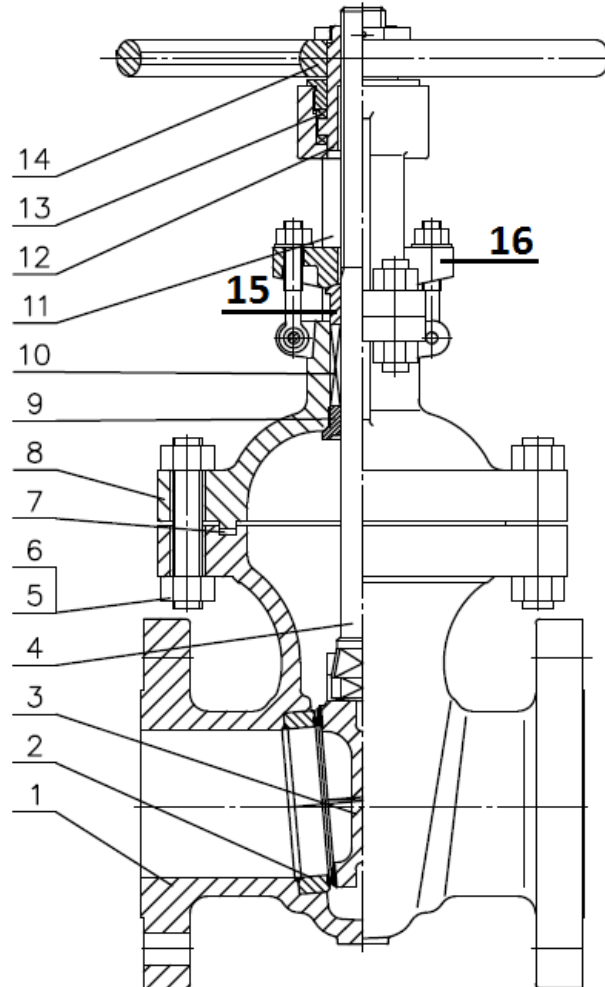

(* : included in gaskets kit)

Item	Designation	Materials
1	Body	ASTM A216 WCB
2	Seat	ASTM A105 + Stellite Gr.6
3	Wedge	ASTM A216 WCB + 13Cr
4	Stem	ASTM A182 F6a
5	Stud bolt	ASTM A193 Gr B7
6	Nut	ASTM A194 Gr 2H
7*	Bonnet gasket	AISI 304 + graphite
8	Bonnet	ASTM A216 WCB
9	Back seat bushing	ASTM A276-420
10*	Packing	Flexible graphite
11	Yoke	ASTM A216 WCB
12	Stem nut	Aluminium + Bronze
13	Ring	E51100
14	Handwheel	Cast iron
15	Packing gland	ASTM A276-420
16	Gland flange	ASTM A216 WCB

CARBON STEEL GATE VALVE FLANGED CLASS 300 PN50 TRIM8

MATERIALS DN400 (NPS 16") :

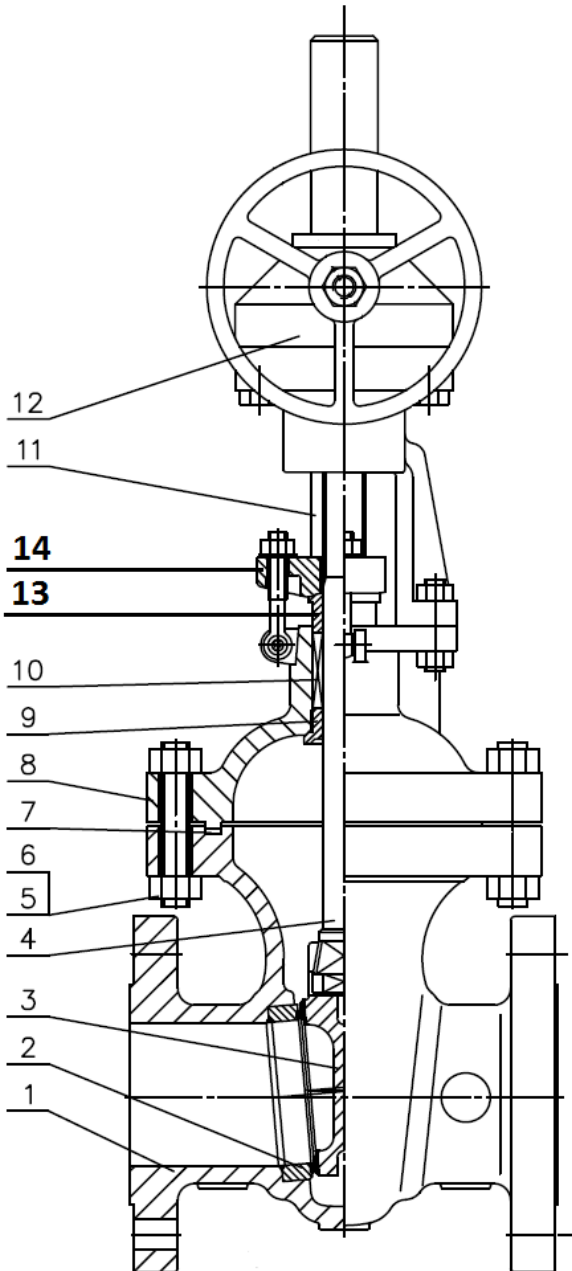

Item	Designation	Materials
1	Body	ASTM A216 WCB
2	Seat	ASTM A105 + Stellite Gr.6
3	Wedge	ASTM A216 WCB + 13Cr
4	Stem	ASTM A182 F6a
5	Stud Bolt	ASTM A193 Gr B7
6	Nut	ASTM A194 Gr 2H
7*	Bonnet gasket	AISI 304 + graphite
8	Bonnet	ASTM A216 WCB
9	Back seat bushing	ASTM A276-420
10*	Packing	Flexible graphite
11	Yoke	ASTM A216 WCB
12	Gearbox	-
13	Packing gland	ASTM A276-420
14	Gland flange	ASTM A216 WCB

(* : included in gaskets kit)

CARBON STEEL GATE VALVE FLANGED CLASS 300 PN50 TRIM8

SIZE DN50-350 (NPS 2" to 14") (in mm) :

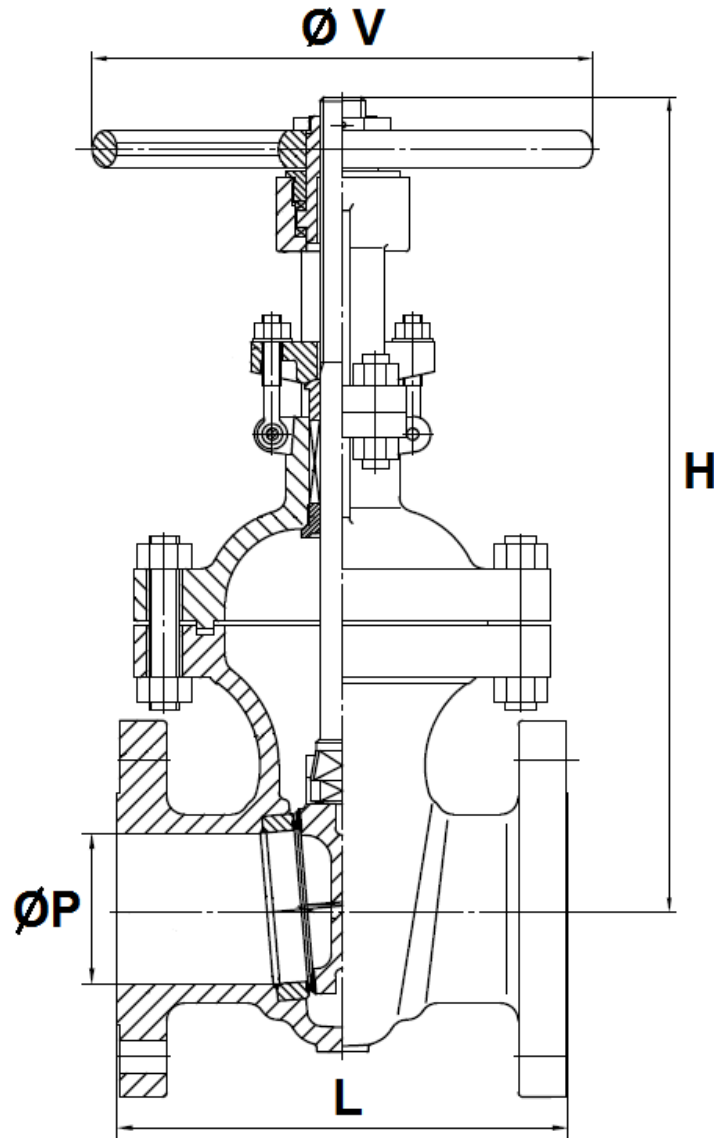

DN (mm)	50	80	100	150	200	250	300	350
NPS (")	2"	3"	4"	6"	8"	10"	12"	14"
Ø P	51	76	102	152	203	254	305	334
L	216	283	305	403	419	457	502	762
H (opened)	402	538	616	817	992	1249	1415	1574
H (closed)	335	445	505	647	771	975	1085	1214
Ø V	240	280	300	400	400	500	500	600
Weight (Kg)	23	48	69	130	189	297	439	650
Ref.	144050	144080	144100	144150	144200	144250	144300	144350

CARBON STEEL GATE VALVE FLANGED CLASS 300 PN50 TRIM8

SIZE DN 400 (NPS 16") (in mm) :

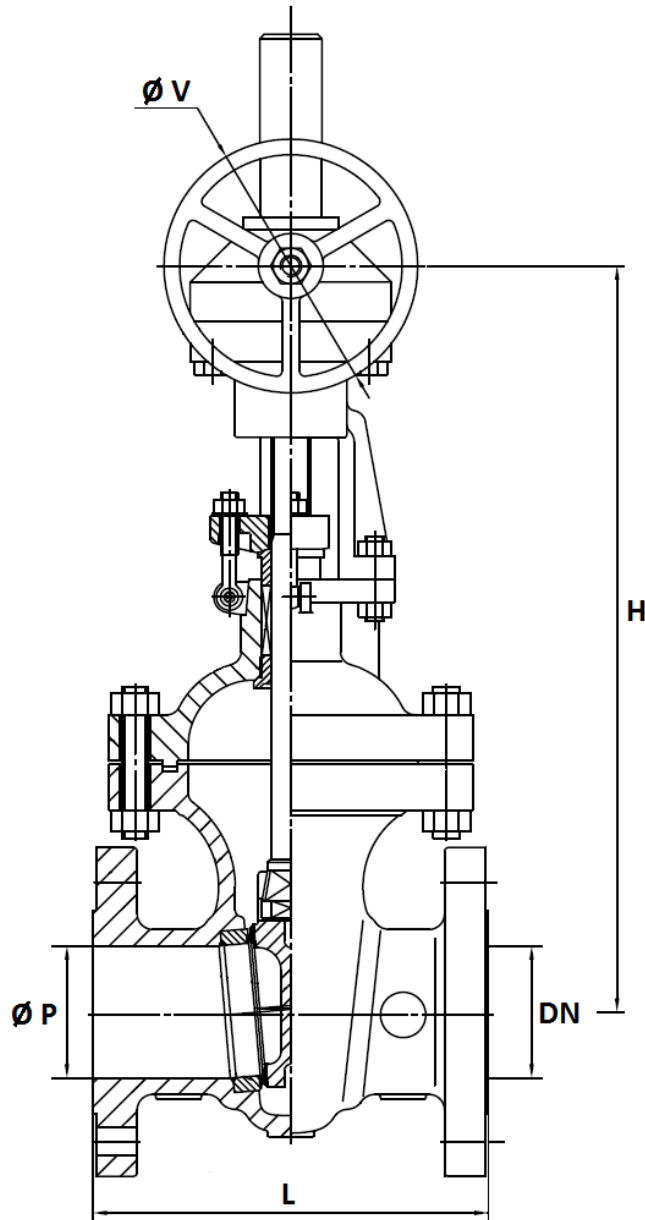

Ref.	DN (mm)	400
	NPS (")	16"
144400	$\varnothing P$	385
	L	838
	H	1455
	$\varnothing V$	530
	Weight (in Kg)	805

CARBON STEEL GATE VALVE FLANGED CLASS 300 PN50 TRIM8**STANDARDS :**

- Manufacturer certified ISO 9001 : 2015 and ISO 14001 : 2015
- DIRECTIVE 2014/68/EU : CE N° 0036
Risk category III Module H
- Certificate 3.1 on request
- Designing according to API 600
- Pressure Tests according to API 598, table 6
- Length according to ASME B16.10, table 2 A10 series and EN 558 series 4
- Flanges R.F. according to ASME B16.05 Class 300
- Fire safe according to API SPEC 6FA 3th edition 04-1999
- ATEX Group II Category 2 G/2D Zone 1 & 21 Zone 2 & 22 (optional marking) according to directive 2014/34/EU
- Materials according to NACE MR 01-75 **on request**