

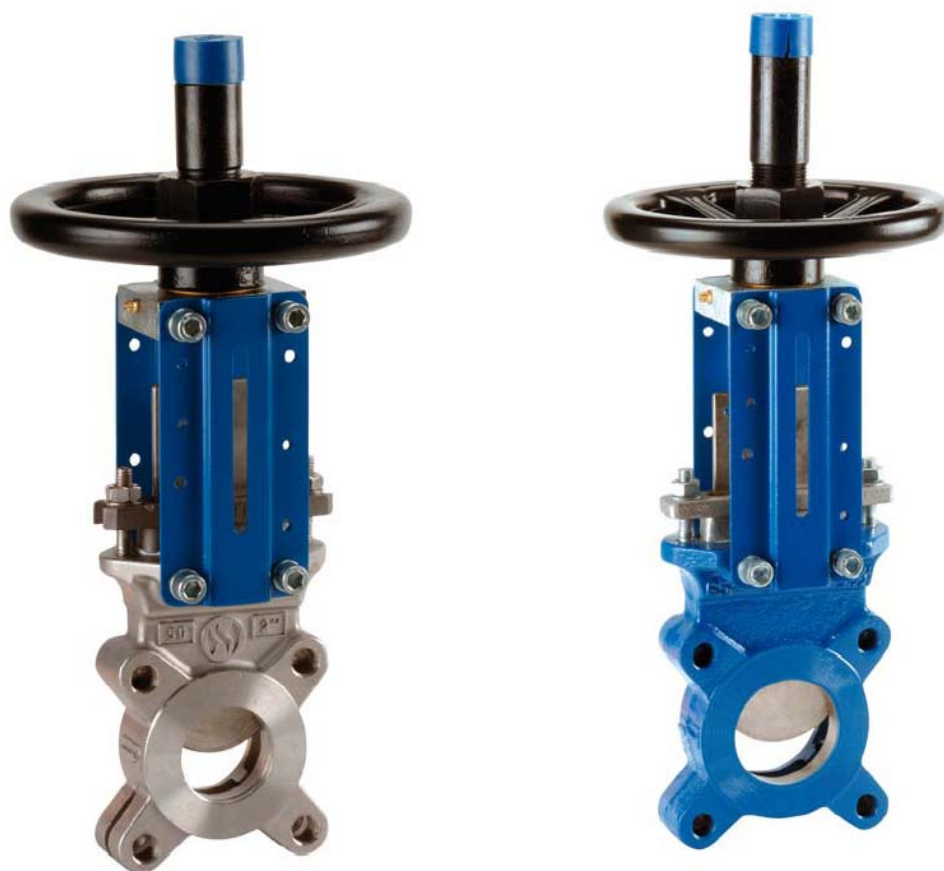

ARMATURY A POTRUBNÍ DÍLY, s.r.o., Kapitána Jaroše 256, 595 01 Velká Bíteš, CZECH REPUBLIC - EUROPE
www.arpod.cz, email info@arpod.cz, tel.+00420 566 531 031, fax.+00420 566 531 034

S76.1.170/176 PN10

Knife gate valve



Size : DN 50 to DN 700
Ends : Between flanges GN10
Min Temperature : -10°C for cast iron type (-15°C for S.S.)
Max Temperature : + 90°C for cast iron type (+ 100°C for S.S.)
Max Pressure : 10 Bars up to DN 200
Specifications : Rising rotating stem , non rising handwheel
Unidirectional tightness
Weak head loss

Materials : Cast iron or Stainless steel



ARMATURY A POTRUBNÍ DÍLY, s.r.o., Kapitána Jaroše 256, 595 01 Velká Bíteš, CZECH REPUBLIC - EUROPE
www.arpod.cz, email info@arpod.cz, tel.+00420 566 531 031, fax.+00420 566 531 034

SPECIFICATIONS :

- Opened or closed valve
- Rising rotating stem, non rising handwheel
- Unidirectional tightness (Respect the flow direction indicated by the arrow)
- Weak head loss
- Between flanges GN10
- Full crossing threaded lower holes and blind threaded top holes
- With handwheel
- With lever or chain handwheel (option)
- Possible with bipolar sensor O + C , voltage AC 15-240V 3A, IP66 type XCK M115C
- Deflector (option)
- 50% epoxy 50% polyester painting blue colour RAL 5017

USE :

- Water, water treatment, chemical pulp, powders, food industry, chemistry
- Min and max Temperature Ts : - 10°C to + 90°C for cast iron body **Ref.170**
- Min and max Temperature Ts : - 15°C to + 100°C for stainless steel body **Ref.172**
- When using powders, inverse flow direction

MAX PRESSURE :

DN	50	65	80	100	125	150	200	250	300	350	400	450	500	600	700
Ps (Bars)	10	10	10	10	10	10	10	8	6	4	4	3	3	3	2

RANGE :

- Between flanges GN10 cast iron body, SS 304 gate, NBR seat, with handwheel **Ref. 170** from DN 50 to DN 700
- Between flanges GN10 SS CF8M body, SS 316 gate , EPDM seat, with handwheel **Ref. 172** from DN 50 to DN 400
- With chain handwheel (**Ref. 980179**) from DN 50 to DN 600
- With lever (**Ref. 980178**) from DN 50 to DN 300
- Option with deflector (**Ref. 98018**)
- Option with bipolar sensors O + C (**Ref. 980135**) from DN 50 to DN 700



MATERIALS WITH HANDWHEEL (REF. 170 AND 172) :

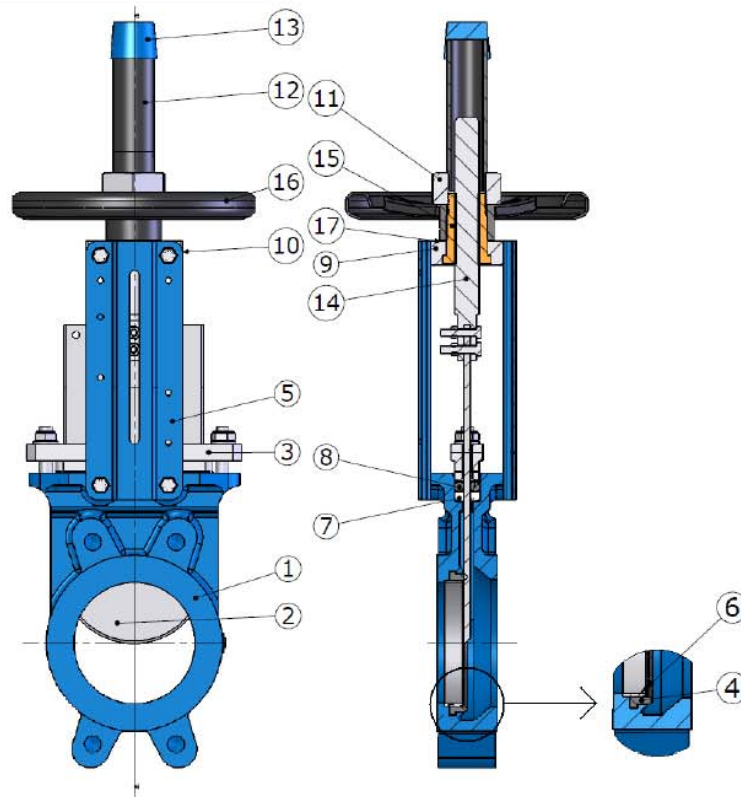

Item	Designation	Materials Ref. 170	Materials Ref. 172
1	Body	Cast iron EN GJL-250	ASTM A351 CF8M
2	Gate	SS 304	SS 316
3	Packing gland nut DN50 – DN 200	Aluminium	ASTM A351 CF8M
3	Packing gland nut DN 250 – 700	Cast iron EN GJL-250	ASTM A351 CF8M
4(*)	Seat	NBR	EPDM
5	Support	Painted steel	Painted steel
6(*)	Retainer	SS 304	SS 316
7(+)	Packing (Tress)	PTFE	PTFE
8(+)	Packing (O ring)	NBR	EPDM
9	Yoke	Steel	Steel
10	Oil hole	Steel	Steel
11	Fixing screw	Steel	Steel
12	Hood	Steel	Steel
13	Hood cover	Plastic	Plastic
14	Spindle	SS 303	SS 303
15	Stem nut	Bronze	Bronze
16	Handwheel	Steel	Steel
17	Washer	Brass	Brass

(*) : Included in seat seal kit
 (+) : Included in packing gland kit

MATERIALS WITH CHAIN HANDWHEEL :

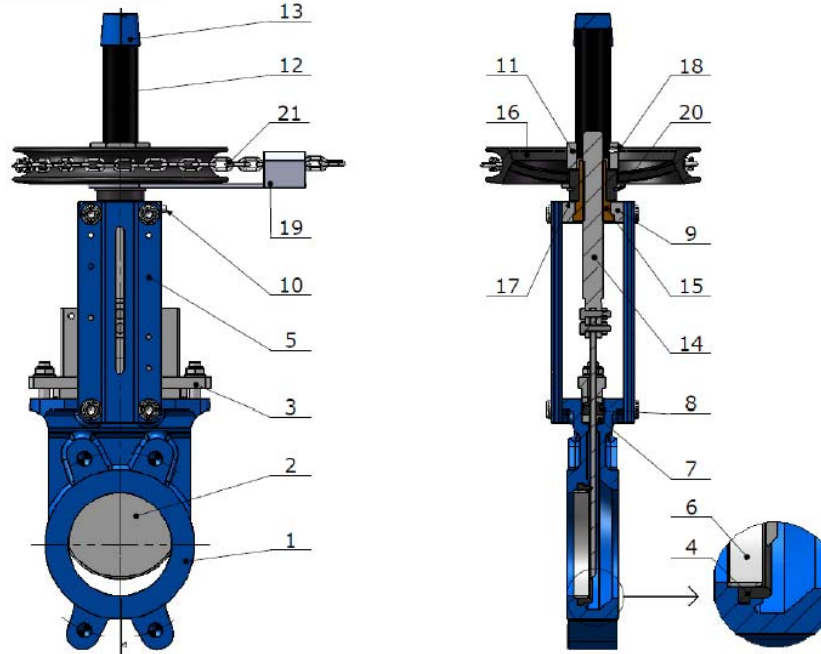

Item	Designation	Materials Ref. 170 + 980179	Materials Ref. 172 + 980179
1	Body	Cast iron EN GJL-250	ASTM A351 CF8M
2	Gate	SS 304	SS 316
3	Packing gland nut DN50 – DN 200	Aluminium	ASTM A351 CF8M
3	Packing gland nut DN 250 – 600	Cast iron EN GJL-250	ASTM A351 CF8M
4(*)	Seat	NBR	EPDM
5	Support	Painted steel	Painted steel
6(*)	Retainer	SS 304	SS 316
7(+)	Packing (Tress)	PTFE	PTFE
8(+)	Packing (O ring)	NBR	EPDM
9	Yoke	Steel	Steel
10	Oil hole	Steel	Steel
11	Fixing screw	Steel	Steel
12	Hood	Steel	Steel
13	Hood cover	Plastic	Plastic
14	Spindle	SS 303	SS 303
15	Stem nut	Bronze	Bronze
16	Handwheel	Steel	Steel
17	Washer	Brass	Brass
18	Fixing screw	SS 304	SS 304
19	Chain guide	Cast iron	Cast iron
20	Washer	Brass	Brass
21	Chain	Steel or stainless steel	Steel or stainless steel

(*) : Included in seat seal kit
 (+) : Included in packing gland kit

MATERIALS WITH LEVER :

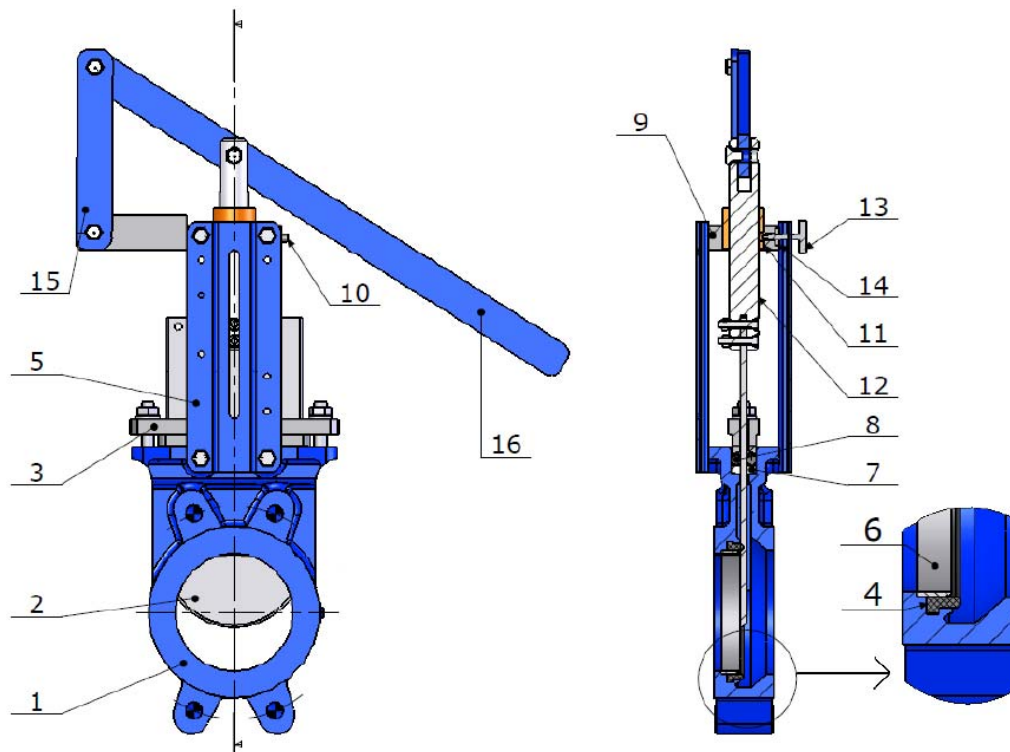

Item	Designation	Materials Ref. 170 + 980178	Materials Ref. 172 + 980178
1	Body	Cast iron EN GJL-250	ASTM A351 CF8M
2	Gate	SS 304	SS 316
3	Packing gland nut DN50 – DN 200	Aluminium	ASTM A351 CF8M
3	Packing gland nut DN 250 – 300	Cast iron EN GJL-250	ASTM A351 CF8M
4(*)	Seat	NBR	EPDM
5	Support	Painted steel	Painted steel
6(*)	Retainer	SS 304	SS 316
7(+)	Packing (Tress)	PTFE	PTFE
8(+)	Packing (O ring)	NBR	EPDM
9	Yoke	Steel	Steel
10	Oil hole	Steel	Steel
11	Stem nut	Bronze	Bronze
12	Spindle	SS 303	SS 303
13	Fixing screw	Steel	Steel
14	Wedge	Steel	Steel
15	Link	Steel	Steel
16	Lever	Steel	Steel

(*) :: Included in seat seal kit

(+) :: Included in packing gland kit



SIZE WITH HANDWHEEL REF.170-172 (in mm) :

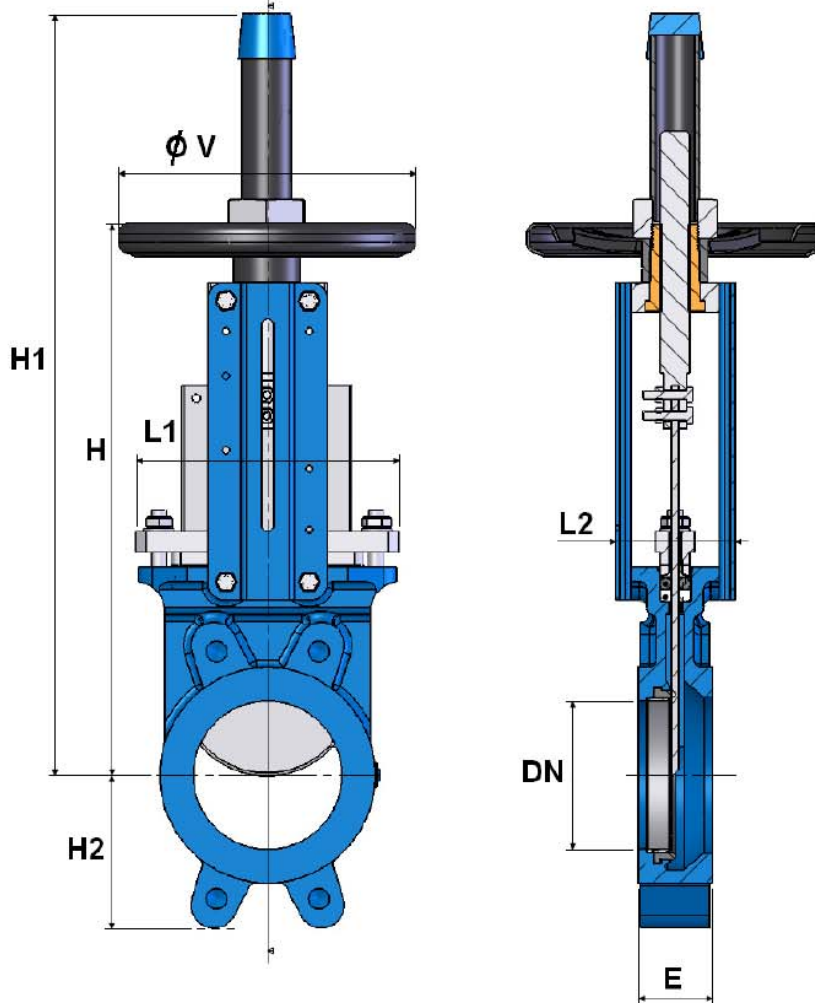

DN	50	65	80	100	125	150	200	250	300	350	400	450	500	600	700
E	40	40	50	50	50	60	60	70	70	96	100	106	110	110	110
H	289	316	342	382	415	458	575	676	776	906	1012	1098	1210	1416	1611
H1	409	436	462	502	585	637	815	1016	1116	1336	1442	1628	1740	2046	2461
H2	63	70	92	105	120	130	160	198	234	256	292	308	340	400	452
L1	124	139	154	174	192	217	270	326	380	438	493	546	620	714	830
L2	92	92	92	92	102	102	119	119	119	290	290	290	290	290	320
Ø V	185	185	185	185	225	225	325	325	380	450	450	450	450	450	620
Weig. Ref.170(Kg)	6.53	7.1	8.53	9.8	12.7	16.16	26.8	43.5	57.5	108	132	170	210	298	446
Weig. Ref.172(Kg)	6.52	7.81	8.48	10.06	12.7	15.8	27.8	44.6	58.6	110	150	-	-	-	-



ARMATURY A POTRUBNÍ DÍLY, s.r.o., Kapitána Jaroše 256, 595 01 Velká Bíteš, CZECH REPUBLIC - EUROPE
www.arpod.cz, email info@arpod.cz, tel.+00420 566 531 031, fax.+00420 566 531 034

SIZE WITH CHAIN HANDWHEEL REF.170-172 + 980179 (in mm) :

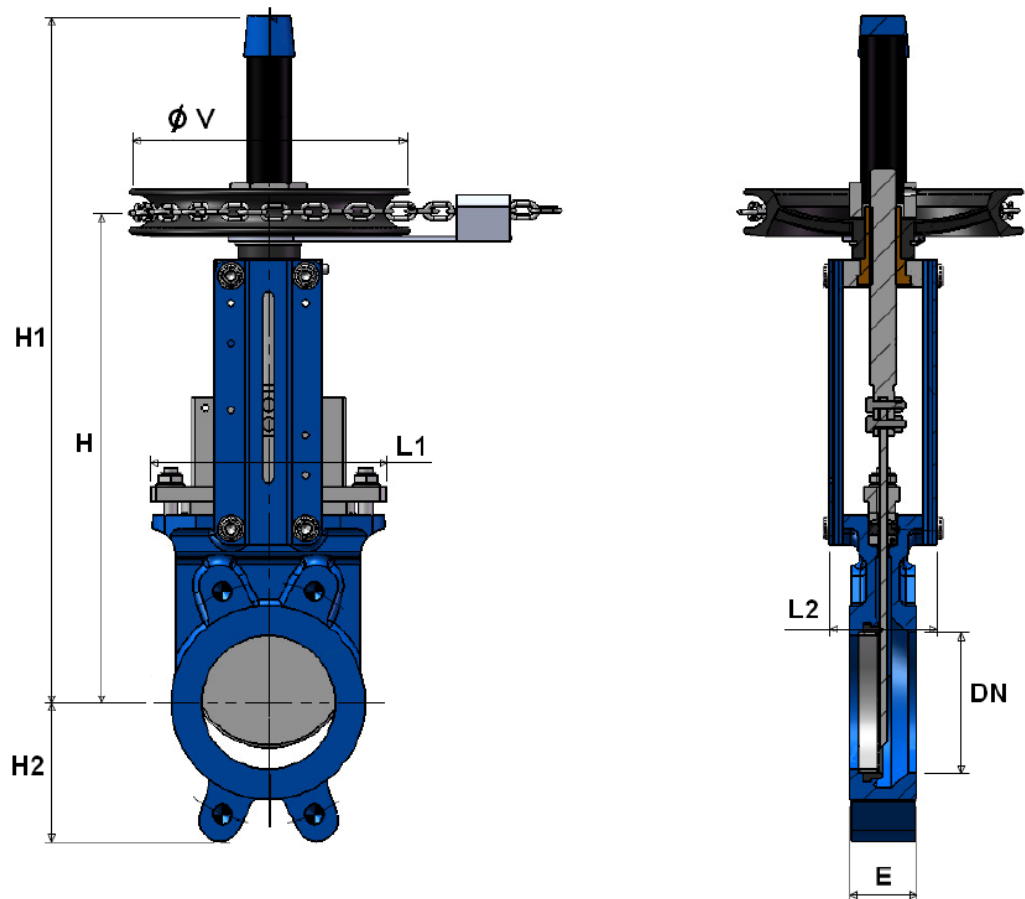

DN	50	65	80	100	125	150	200	250	300	350	400	450	500	600
E	40	40	50	50	50	60	60	70	70	96	100	106	110	110
H	289	316	342	382	415	458	575	676	776	906	1012	1098	1210	1416
H1	409	436	462	502	585	637	815	1016	1116	1336	1442	1628	1740	2046
H2	63	70	92	105	120	130	160	198	234	256	292	308	340	400
L1	124	139	154	174	192	217	270	326	380	438	493	546	620	714
L2	92	92	92	92	102	102	119	119	119	290	290	290	290	290
Ø V	212	212	212	212	212	212	296	296	296	482	482	482	482	482
Weig. Ref.170 + 980179 (Kg)	11.4	12	13.4	14.7	17.6	21	34.3	51	65	122.5	146.5	184.5	224.5	312.5
Weig. Ref.172 + 980179 (Kg)	11.4	12.7	13.4	14.9	17.6	20.7	35.3	52.1	66.1	124.5	164.5	-	-	-



SIZE WITH LEVER REF.170-172 + 980178 (in mm) :

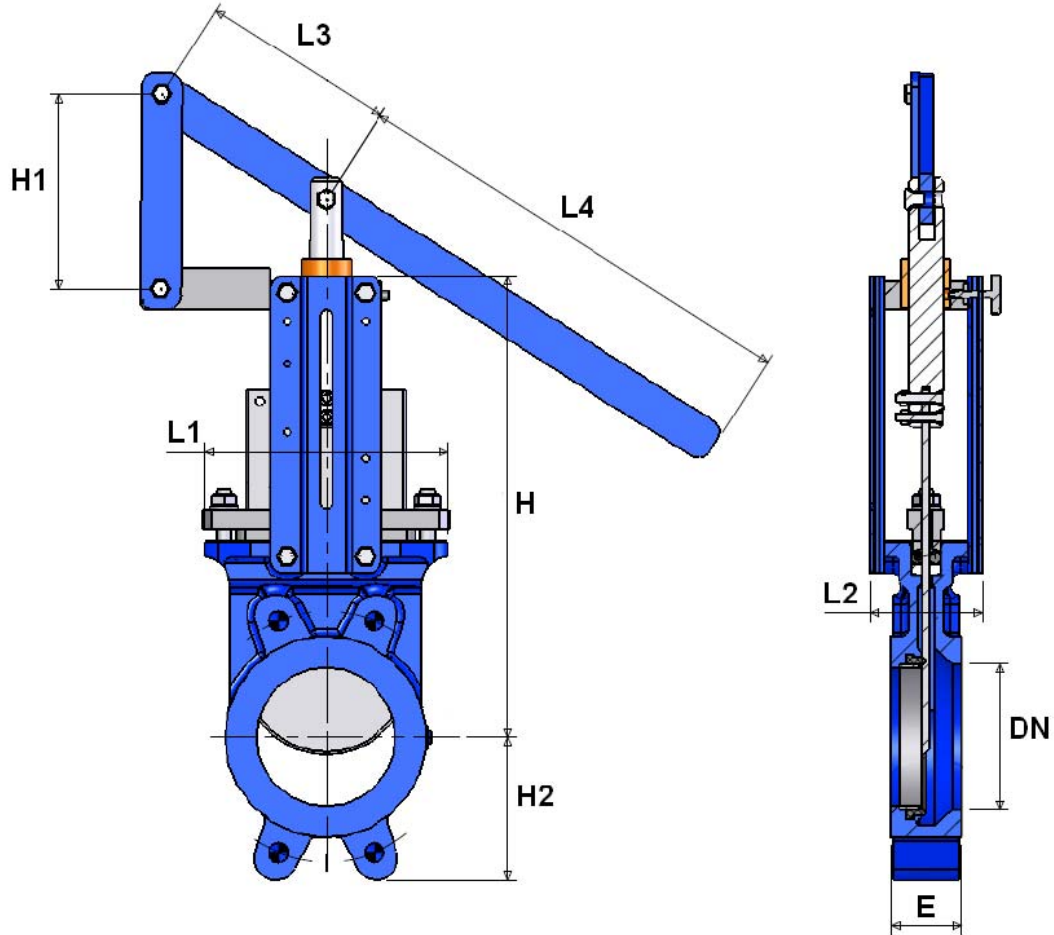

DN	50	65	80	100	125	150	200	250	300
E	40	40	50	50	50	60	60	70	70
H	240	265	290	335	373	424	533	625	732
H1	125	125	125	125	170	170	190	285	285
H2	63	70	92	105	120	130	160	198	234
L1	124	139	154	174	189	220	275	326	380
L2	83	83	83	83	93	93	108	108	108
L3	140	140	140	140	140	140	230	230	230
L4	340	340	340	340	440	440	640	680	680
Weig. Ref.170 or 172 + 980178 (Kg)	8.9	9.8	11	13.3	16	18.9	32.9	53.6	67.3



ARMATURY A POTRUBNÍ DÍLY, s.r.o., Kapitána Jaroše 256, 595 01 Velká Bíteš, CZECH REPUBLIC - EUROPE
www.arpod.cz, email info@arpod.cz, tel.+00420 566 531 031, fax.+00420 566 531 034

SIZE FIXING VALVE THREADED HOLES (BETWEEN FLANGES GN10 in mm) :

DN 50 – 65

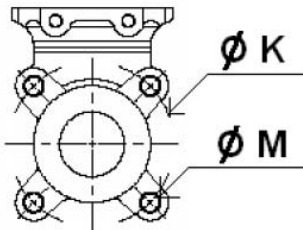

DN 80 – 200

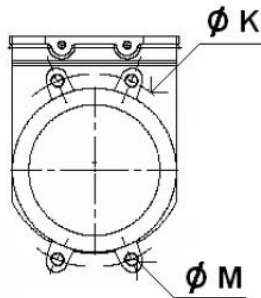

DN 250 - 300

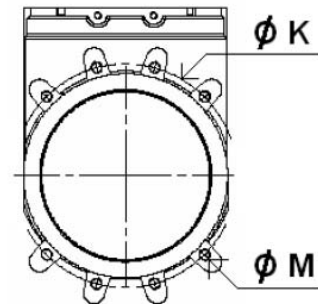

DN 350 – 400

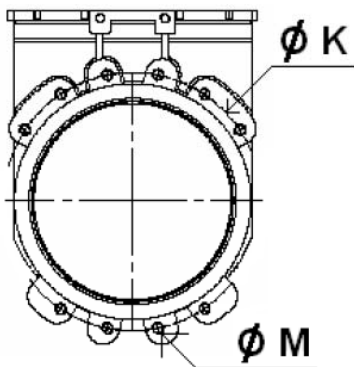

DN 450 – 600

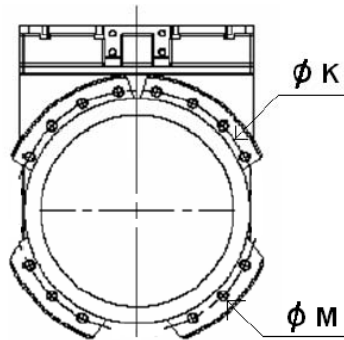

DN 700

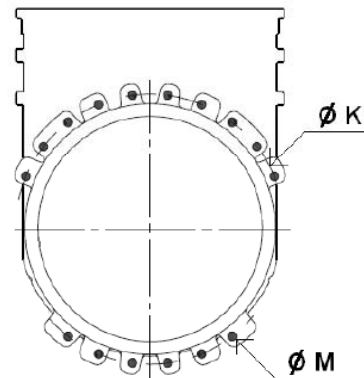

THREADED LENGHT FOR TOP BLIND HOLES :

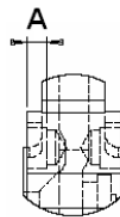

DN	50	65	80	100	125	150	200	250	300	350	400	450	500	600	700
Ø K	125	145	160	180	210	240	295	350	400	460	515	565	620	725	840
Ø M	M16	M16	M16	M16	M16	M20	M20	M20	M20	M20	M24	M24	M24	M27	M27
Nb threaded hole	4	4	4	4	4	4	4	8	8	10	10	14	14	14	16
A	8	8	9	9	9	10	10	12	12	20	20	22	22	22	22



ARMATURY A POTRUBNÍ DÍLY, s.r.o., Kapitána Jaroše 256, 595 01 Velká Bíteš, CZECH REPUBLIC - EUROPE
www.arpod.cz, email info@arpod.cz, tel.+00420 566 531 031, fax.+00420 566 531 034

SENSOR SIZE (in mm) AND SCHEMA :

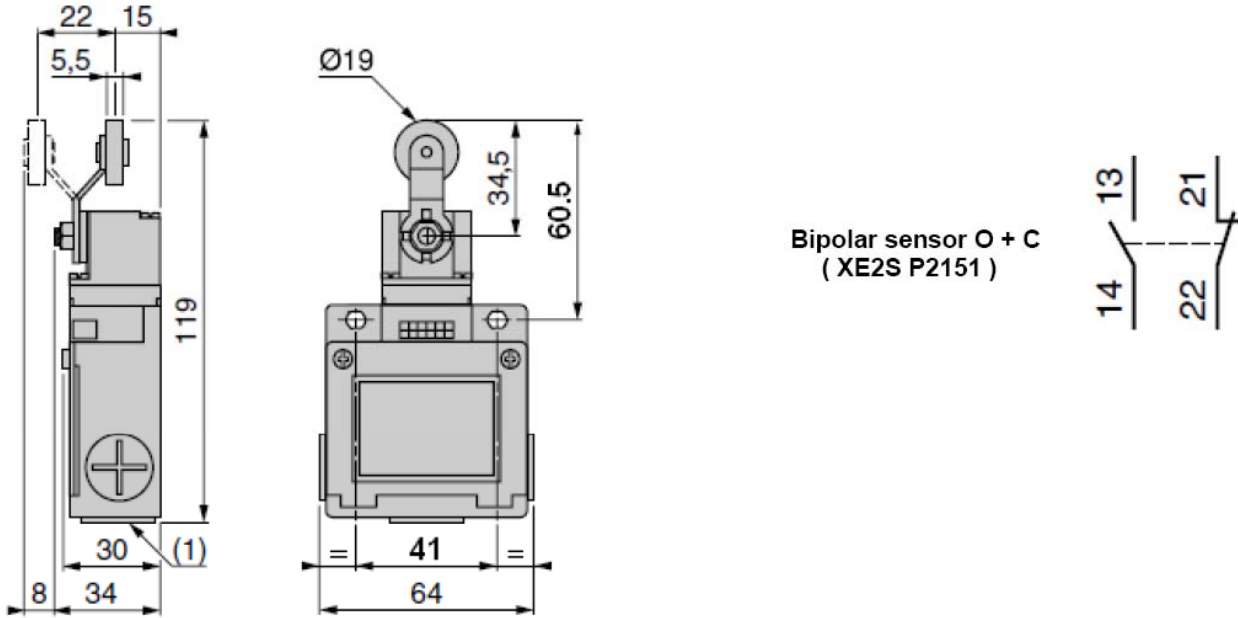

STANDARDS :

- Between flanges GN10 according to EN 1092-2 PN10