

SK 61 – ODVADEČ KONDENZÁTU PLOVÁKOVÝ PŘÍRUBOVÝ

MAIN CHARACTERISTICS

The SK 61 steam trap is float trap dedicated to the draining of condensate in the steam lines. SK61 has a stainless steel body with threaded or flanged connections PN 16/25 with DIN 2533 face to face dimension. This steam trap is able to drain large capacities of condensate and is well adapted to the variations of flowrates. For this reason it is recommended for the draining of process like heat exchangers, autoclaves, condensers in the field of chemical processing, food and drugs industries. As a standard the SK61 is fitted with an thermostatic capsule for air elimination in starting phase. It must be installed horizontally and several mechanisms are available depending on the differential pressure.



AVAILABLE MODELS

BSP threaded connections 1/2" - 3/4" - 1"

DN15,20 and 25 flanged connections PN16/25/40

ΔP 4,5 / 10 / 14 bar

CLASSIFICATION ACC. TO PED 97/23

Homologation CE 0036 cat. II

LIMITS OF USE

Maximum operating pressure PS : 25 bar

Maximum operating temperature TS : 250°C

CONSTRUCTION

N°	Item	Material
1	Body	Stainless steel 1.4408
2	Cover	Stainless steel 1.4408
3	Gasket	Graphite-stainless steel
4	Therm. capsule	SS AISI 304 / hastelloy
5	Seat (air)	SS AISI 304
6	Seat (condensate)	SS AISI 304
7	Lever	SS AISI 304
8	Float	SS AISI 304

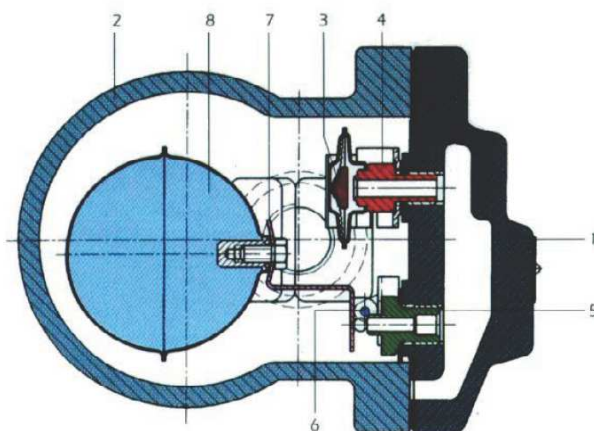

DIMENSIONS (mm)

DN	A	K	B	B1	C	D
15	150	150	108	105	68	122
20	150	150	108	105	68	122
25	160	167	108	110	107	145

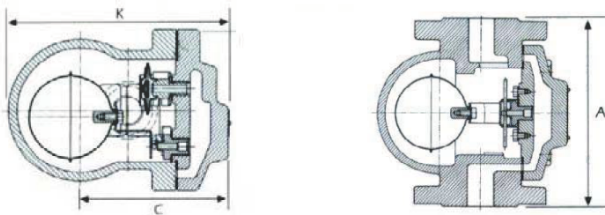

FLOWRATES (kg/h)

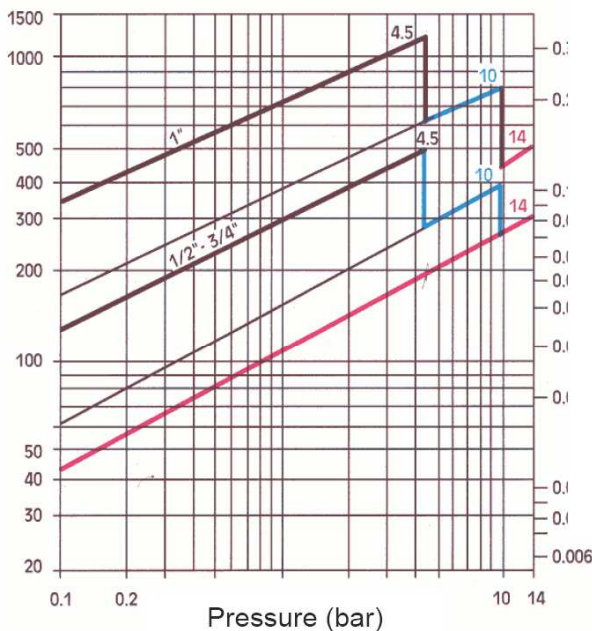

INSTRUCTIONS FOR INSTALLATION

The SK61 steam trap must be installed at the lowest point of the piping to drain. As a standard, it is delivered for horizontal installation. Upstream the trap it is recommended to install a shut-off valve and a Y strainer to avoid any damage on the seat due to the passing of impurities. Downstream the trap must be connected to the condensate loop or to the sewage.

While installing the SK61, the right position has to be respected to allow the operation of the trap. Please respect the following two directions:

1 / SK61 has to be installed horizontally taking care of the direction of the arrow stamped on the body : from steam pipe (upstream) to condensate pipe (downstream).

2 / Moreover the arrow written on the nameplate must be pointed to the ground.

Before installing the trap, shut of the line and remove the pressure. Wait for complete cooling of the line before any operating. Clean carefully the upstream line. Screw the trap on the line after having verified the direction of the two arrows. For the flanged type, use flange's gaskets adapted to steam service. For the bolting of the flanges, use following dimensions.

Size	N° of bolts	Diameter	Length
15 and 20	4	M14	50
25	4	M16	60
32, 40 et 50	4	M16	110

DIS-ASSEMBLING AND MAINTAINING

It is not necessary to disassemble the trap from the pipe to proceed to his maintaining :

1. Shutt-off the upstream valve.
2. Drain the downstream line.
3. Verify that there is no pressure and temperature inside the line.
4. Unscrew the 4 bolts of the cover (item 2).
5. Verify the state of the float (item 8). Also verify the state of the lever and the seat (item 5). Clean and/or replace the damaged parts if necessary.
6. Verify the state of the capsule (item 4). Replace it if necessary and clean the seat.
7. Replace the body gasket (item 3) and re-assemble the cover (item 2).