

V25 111 540 – VENTIL UZAVÍRACÍ PŘÍRUBOVÝ S VLNOCEM

Design

- Bellow sealed globe valve in forged and cast steel
- Straight pattern with bolted bonnet
- Rising, non rotating stem
- Increased stem nut positioning,
- Blowout safety bonnet sealing
- Flange- or BW-ends
- Welded seat
- Seat in stellite or Cr-steel
- Self adjusted gland

Standard

- Design EN 13709
EN 12516
- Face to face EN 558-1
EN12982
- Flange EN1092-1
- Bellows MSS-SP 117
- BW-ends EN12627
- Markning EN 19
- Pressure test EN12266-1
- CE-mark according PED97/23, category 3

Applications

- Water, steam, and other medium which not damage the internal components
- Uses within the all kind of industries
- The valves are designed for shut of application or simple regulation

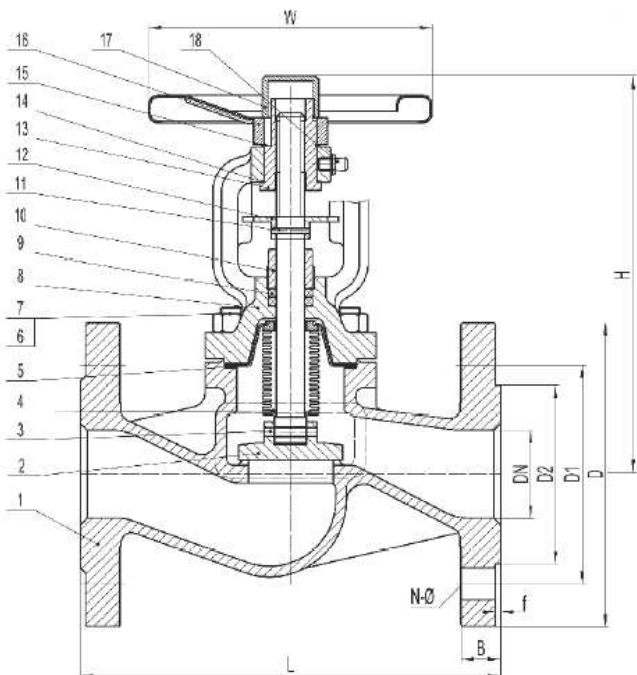

Tlakoteplotní oblast pro materiály / Pressure - temperature range for material in group 3E0, 5E0, 13E0, 14E0

Materiál	PN	RT	Teplota / Temperature										
			100	150	200	250	300	350	400	450	500	520	530
Carbon steel 3E0, 1.0619	25/40	40	37,3	34,7	30,2	28,4	25,8	24	23,1				
Alloy steel 5E0, 1.7357/1		40	40	40	40	39,1	36,4	33,8	32	30,2	24,4	16,7	13,5

Tabulka rozměrů / Table of dimensions

DN	L	D	D1	D2	b	N - o	H
15	130	95	65	45	16	4x14	174
20	150	105	75	58	18	4x14	176
25	160	115	85	68	18	4x14	207
32	180	140	100	78	18	4x18	207
40	200	150	110	88	18	4x18	210
50	230	165	125	102	20	4x18	225
65	290	185	145	122	22	8x18	250
80	310	200	160	138	24	8x18	260
100	350	235	190	162	24	8x22	345
125	400	270	220	188	26	8x26	370
150	480	300	250	218	28	8x26	430
200	600	375	320	295	34	12x30	488
250	730	450	385	345	38	12x33	530
300	850	515	450	410	42	16x33	600
350	980	580	510	485	46	16x36	850
400	1100	660	585	535	50	16x39	1000