

Gate valves [GAC]

Standard: API 600 (ISO 10434)

DN 50 (2") ÷ DN 600 (24")
Class 150 ÷ Class 1500

Design

- Casted body and bonnet
- Bolted bonnet (BB)
- Rising stem (RS), outside screw and yoke (OS&Y)
- Wedge may be one-piece flexible, solid or split wedge type

Applications

- Refining, Petrochemical, Chemical, Power plant

Media

- Depending on the gate valve materials: water, steam, gas, oil and oil derivatives and other non aggressive media

Pressure and temperature (table D.2.4)

- Class 150 ÷ Class 1500
- Temperature up to 600 °C

Materials (table D.2.1)

- Carbon, heat resistant alloy and stainless steels

Advantages

- Long service life
- Respect to emission standards
- Easy handling and maintenance
- Stem packing replacement in working conditions

Options

- Electric, hydraulic or pneumatic actuator
- Position indicator
- Extended stem
- Locking device
- Non rising stem and solid wedge
- Flanges and welding ends according to: GOST, DIN, EN.
- Other paint finishes are available upon customer's request
- Gate valve complete with counter flanges, bolting and gaskets.

Testing

- Every produced gate valve was tested according to API 598 (ISO 5208)

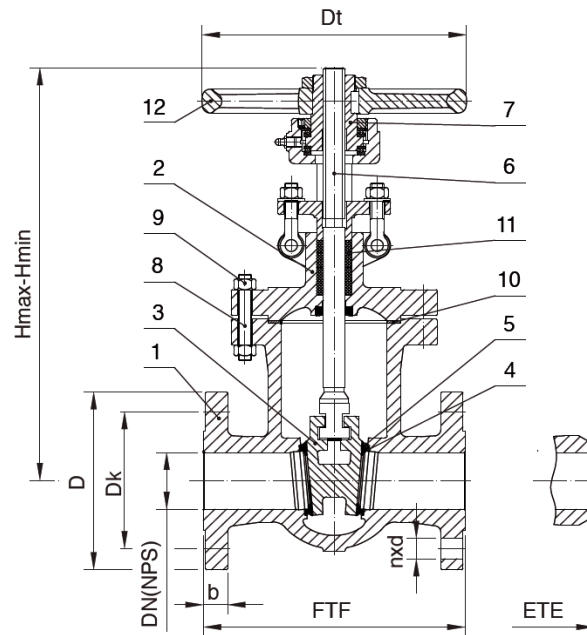

Drawing D.2.1 Parts and dimensions

List of materials

Table D.2.1

Item	Part	Groups of materials according to ASME B16.34					
		1.1	1.3	1.9	1.13	2.2	2.11
		Application					
		-29°C÷425°C	-40°C÷345°C	-29°C÷550°C	-29°C÷550°C	-196°C÷600°C	-196°C÷600°C
		Material Code					
		13	15	23	27	43	45
1	Body	A216 WCB	A352 LCB	A217 WC6	A217 C5	A351 CF8M	A351 CF8C
2	Bonnet	A216 WCB	A352 LCB	A217 WC6	A217 C5	A351 CF8M	A351 CF8C
3	Wedge	A216 WCB	A352 LCB	A217 WC6	A217 C5	A351 CF8M	A351 CF8C
4	Trim	Body Seats	13Cr	HF (Stellite)	13Cr	Basic material or Stellite	
5		Disc Seats	13Cr	HF (Stellite)	13Cr	Basic material or Stellite	
6		Stem	SS 420			SS 304 / SS 316	
7	Stem Nut	Cu alloy					
8	Stud Bolts	A193 B7		A193 B16 / 1.7709		A193 B8 or A193 B8M	
9	Nuts	A194 2H		A194 4 / 1.7709		A194 8 or A194 8M	
10	Bonnet Gasket	Class 150: reinforced pure graphite, Class 300÷1500: spiral wound or oval metal ring					
11	Stem Packing	braided graphite with corrosion inhibitor					
12	Handwheel	cast carbon steel					

Standards

Table D.2.2

Gate valve according to API 600 (ISO 10434)	Class 150 ÷ Class 1500
Face-to-face and End-to-end dimensions according to	ASME/ANSI B16.10
Flanged ends according to	ASME/ANSI B16.5
Welding ends according to	ASME/ANSI B16.25

S38

GATE VALVE API 600 Class 150 ÷ Class 1500 DN50 (2") ÷ DN600 (24") type S38 111 (121) xxxx

[GAC] Dimensions Class 150 ÷ Class 1500

Table D.2.3

DN (NPS)	FTF	ETE	D	b	Dk	d	n	H max	Hmin	Dt	FTF	ETE
	↔ (mm)										⬇ (kg)	
Class 150												
50 (2)	178	216	150	19,5	120,7	19	4	425	359	250	23	19
65 (2 1/2)	190	241	180	22,7	139,7	19	4	491	409	250	29	23
80 (3)	203	282	190	24,3	152,4	19	4	534	443	250	37	32
100 (4)	229	305	230	24,3	190,5	19	8	670	550	250	50	40
150 (6)	267	403	280	25,9	241,3	22,2	8	854	683	315	86	78
200 (8)	292	419	345	29	298,5	22,2	8	1023	803	400	144	133
250 (10)	330	457	405	30,6	362	25,4	12	1266	991	500	226	205
300 (12)	356	502	485	32,2	431,8	25,4	12	1481	1150	500	323	302
350 (14)	381	572	535	35,4	476,3	28,6	12	1587	1219	500	410	396
400 (16)	406	610	595	37	539,8	28,6	16	1806	1481	630	620	575
450 (18)	432	660	635	40,1	577,9	31,7	16	2103	1642	730	740	690
500 (20)	457	711	700	43,3	635	31,7	20	2323	1795	730	920	890
600 (24)	508	813	815	48,1	749,3	34,9	20	3060	2370	730	1150	1120
Class 300												
50 (2)	216	216	165	22,7	127	19	8	468	394	250	33	24
65 (2 1/2)	241	241	190	25,9	149,2	22,2	8	505	422	250	44	35
80 (3)	282	282	210	29	168,3	22,2	8	556	465	250	52	43
100 (4)	305	305	255	32,2	200	22,2	8	661	553	315	81	73
150 (6)	403	403	320	37	269,9	22,2	12	919	755	400	181	141
200 (8)	419	419	380	41,7	330,2	25,4	12	1030	905	500	254	220
250 (10)	457	457	445	48,1	387,4	28,6	16	1439	1128	500	386	302
300 (12)	502	502	520	51,3	450,8	31,7	16	1623	1292	500	630	504
350 (14)	762	762	585	54,4	514,4	31,7	20	1742	1362	630	880	720
400 (16)	838	838	650	57,6	571,5	34,9	20	2000	1580	730	1030	810
450 (18)	914	914	710	60,8	628,6	34,9	24	2160	1690	730	1420	1120
500 (20)	991	991	775	64	685,8	34,9	24	2395	1865	930	1780	1440
Class 600												
50 (2)	292	292	165	32,4	127	19	8	468	394	250	42	31
65 (2 1/2)	330	330	190	35,6	149,2	22,2	8	522	436	250	53	37
80 (3)	356	356	210	38,8	168,3	22,2	8	566	475	250	63	42
100 (4)	432	432	275	45,1	215,9	25,4	8	659	551	315	122	84
150 (6)	559	559	355	54,7	292,1	28,6	12	929	765	500	250	188
200 (8)	660	660	420	62,6	349,2	31,7	12	1036	911	500	424	318
250 (10)	787	787	510	70,5	431,8	34,9	16	1459	1148	630	685	513
300 (12)	838	838	560	73,7	489	34,9	20	1648	1308	730	900	694
350 (14)	889	889	605	76,9	527	38,1	20	1910	1530	730	1250	846
400 (16)	991	991	685	83,2	603,2	41,3	20	2180	1750	730	1540	1020
Class 900												
50 (2)	368	368	215	45,1	165,1	25,4	8	540	466	315	73	51
65 (2 1/2)	419	419	245	48,3	190,5	28,6	8	653	576	400	123	95
80 (3)	381	381	240	45,1	190,5	25,4	8	630	535	400	107	78
100 (4)	457	457	290	51,5	235	31,7	8	745	626	400	177	131
150 (6)	610	610	380	62,6	317,5	31,7	12	976	785	500	350	250
200 (8)	737	737	470	70,5	393,7	38,1	12	1164	948	630	620	450
250 (10)	838	838	545	76,9	469,9	38,1	16	1448	1168	730	960	716
300 (12)	965	965	610	86,4	533,4	38,1	20	1605	1305	1000	1440	1100
Class 1500												
50 (2)	368	368	215	45,1	165,1	25,4	8	540	466	315	73	51
65 (2 1/2)	419	419	245	48,3	190,5	28,6	8	653	576	400	123	95
80 (3)	470	470	265	54,7	203,2	31,7	8	695	595	400	180	145
100 (4)	546	546	310	61,0	241,3	34,9	8	853	725	500	285	230

Range of application

Table D.2.4

Group Material (Code)	Materials	Class	Pressure (bar)/temperature (°C) ratings according to ANSI B16.34																			
			-29 ÷ 38	50	100	150	200	250	300	325	350	375	400	425	450	475	500	538	550	575	600	
1.1 (13)	A216 WCB	150	20	19	18	16	14	12	10	9	8	7	7	6	5	4	3	1				
		300	51	50	47	45	44	42	40	39	38	36	35	29	23	17	12	6				
		600	102	100	93	90	88	84	80	77	75	73	69	58	46	35	24	12				
		900	153	150	140	135	131	126	120	116	113	109	104	86	69	52	35	18				
		1500	255	251	233	225	219	210	199	194	188	182	174	144	115	87	59	30				
1.3 (15)	A352 LCB	150	18	18	17	16	14	12	10	9	8	7	7	6	5	4	3	1				
		300	48	48	45	44	43	41	39	38	36	35	33	27	22	16	11	6				
		600	96	95	91	88	85	82	77	75	73	70	65	55	43	31	22	12				
		900	144	142	136	132	128	122	116	113	109	105	98	82	65	47	33	18				
		1500	240	237	227	220	213	204	193	188	182	175	163	137	108	78	55	29				
1.9 (23)	A217 WC6	150	20	20	18	16	14	12	10	9	8	7	7	6	5	4	3	1	1	1	1	1
		300	52	52	52	50	48	46	43	41	40	39	37	35	34	32	26	15	13	9	6	6
		600	103	103	103	100	96	93	86	83	80	78	73	70	68	63	52	30	25	18	12	12
		900	155	155	154	149	144	139	129	124	121	117	110	105	101	95	77	45	38	26	18	18
		1500	259	259	257	249	240	232	214	207	201	194	183	175	169	158	129	74	63	44	30	30
1.13 (27)	A217 C5	150	20	20	18	16	14	12	10	9	8	7	7	6	5	4	3	1	1	1	1	1
		300	52	52	52	50	49	46	43	41	40	39	37	35	34	28	21	14	12	9	6	6
		600	103	103	103	100	97	93	86	83	80	78	73	70	68	56	43	27	24	18	13	13
		900	155	155	155	151	146	139	129	124	121	117	110	105	101	84	64	41	36	27	19	19
		1500	259	259	258	251	243	232	214	207	201	194	183	175	169	139	107	69	60	44	31	31
2.2 (43)	A351 CF8M	150	19	18	16	15	14	12	10	9	8	7	7	6	5	4	3	1	1	1	1	1
		300	50	48	42	39	36	33	32	31	30	30	29	29	29	29	28	25	25	24	20	20
		600	99	96	84	77	71	67	63	62	61	60	59	58	58	57	57	50	50	48	40	40
		900	149	144	127	116	107	100	95	93	91	90	88	87	87	86	85	75	75	72	60	60
		1500	248	241	211	192	178	167	158	154	152	149	147	146	144	143	141	126	125	120	99	99
2.11 (45)	A351 CF8C	150	19	19	17	16	14	12	10	9	8	7	7	6	5	4	3	1	1	1	1	1
		300	50	49	45	43	40	38	36	35	35	34	34	34	34	32	28	25	25	24	20	20
		600	99	98	91	85	80	76	72	71	70	68	68	67	67	63	57	50	50	48	40	40
		900	149	146	136	127	120	113	108	106	104	103	102	101	100	95	85	75	75	72	59	59
		1500	248	244	226	212	200	189	180	177	174	171	169	168	167	158	141	126	125	120	99	99

Optional execution

