

F8

F8.000.1503 PN16 DN32-DN600 Expansion joints rubber flange



Size : DN 32 to 600
Ends : Flanges PN10/16
Min Temperature : - 10°C
Max Temperature : + 100°C for EPDM and + 80°C for NBR
Max Pressure : 16 Bars up to DN 300
Specifications : Absorb vibrations and noises
Linear and angular compansion
Single sphere

Materials : Electro galvanized steel flanges

SPECIFICATIONS :

- Absorb vibration, noises and expansion
- Linear and angular compansion
- Tube EPDM (EPDM marking) or NBR (NBR marking)
- Electro galvanized steel flanges PN10/16
- Expansion limiter (option)

Marking example (EPDM) :



USE :

- Water distribution, heating and (for EPDM types)
- Oil, hydrocarbon, air (for NBR types)
- Min and max Temperature Ts : - 10°C to + 100°C for EPDM types (Ref.1501 and 1502)
- Min and max Temperature Ts : - 10°C to + 80°C for NBR type (Ref.1503)
- Max Pressure Ps : 16 bars up to DN300 (see graph) , 10 bars over

PRESSURE / TEMPERATURE GRAPH (STEAM EXCLUDED) REF. 1501-1502 DN 32 – DN 300 :

1501-1502 DN 32 – DN 300

(Bar)

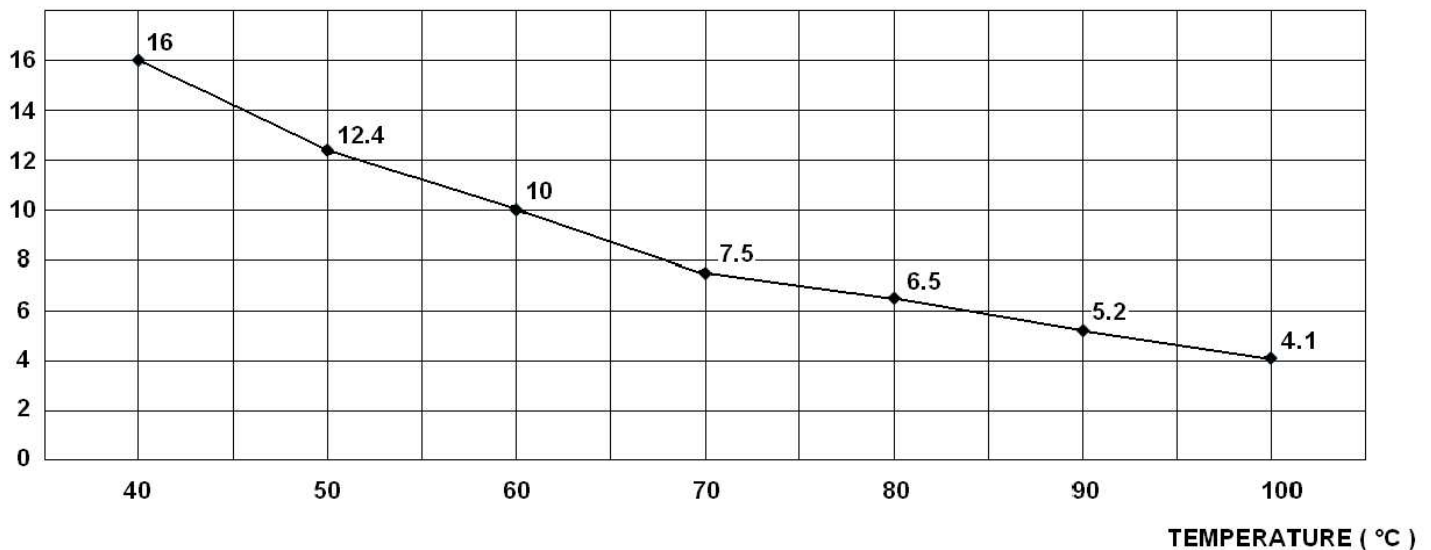

PRESSURE / TEMPERATURE GRAPH (STEAM EXCLUDED) REF. 1501-1502 DN 350 – DN 600 :

1501-1502 DN 350 – DN 600

(Bar)

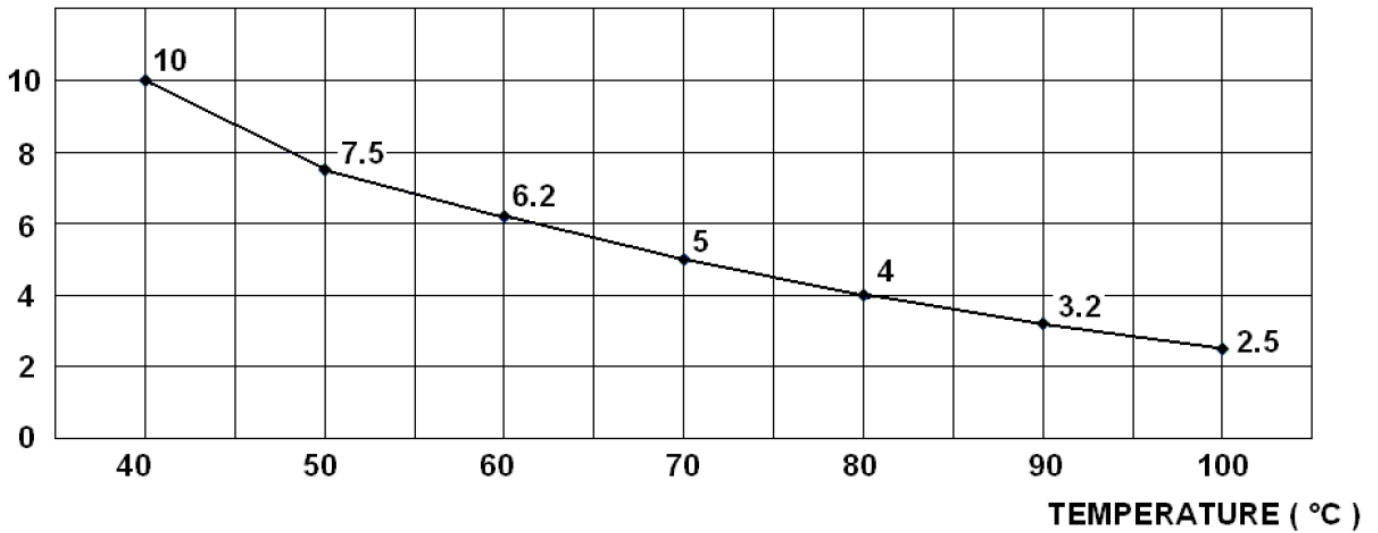

PRESSURE / TEMPERATURE GRAPH (STEAM EXCLUDED) REF. 1503 DN 32 - 200 :

1503 DN 32 – DN 200

(Bar)

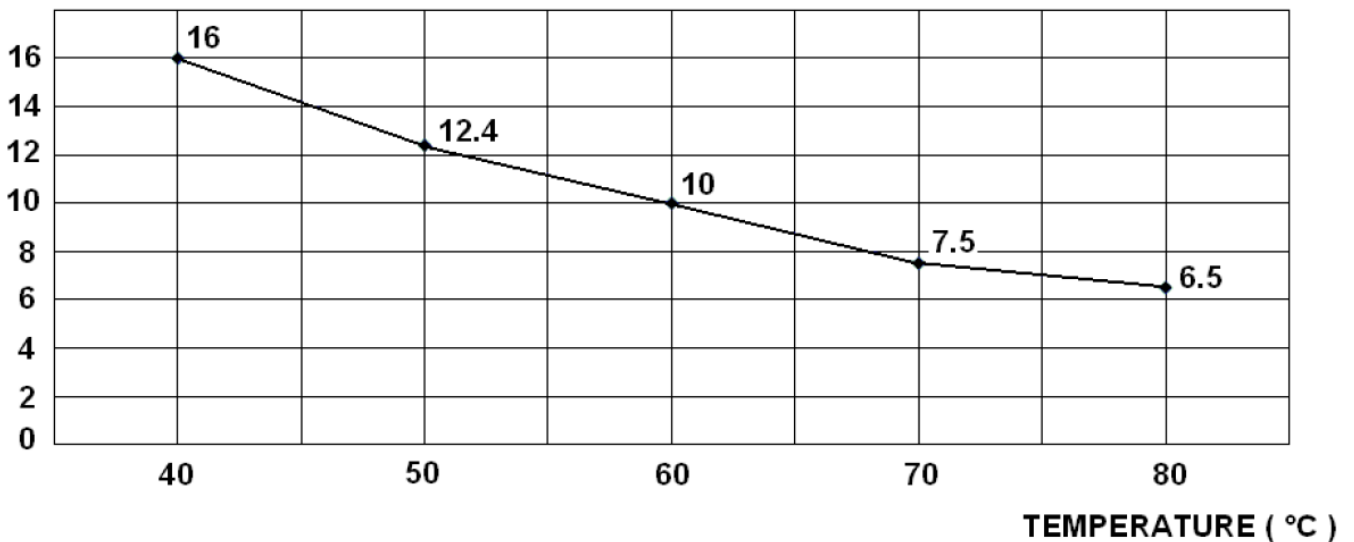

RANGE :

- EPDM expansion joint with steel flanges PN10 from DN 32 to DN 600 Ref. 1501
- EPDM expansion joint with steel flanges PN16 from DN 200 to DN 300 Ref. 1502
- NBR expansion joint with steel flanges PN10 from DN 32 to DN 200 Ref. 1503
- Expansion limiter (with 2 studs and 4 plates included) PN10 from DN 32 to DN 600 Ref. 98604
- Expansion limiter (with 2 studs and 4 plates included) PN16 from DN 200 to DN 300 Ref. 98603

MATERIALS :

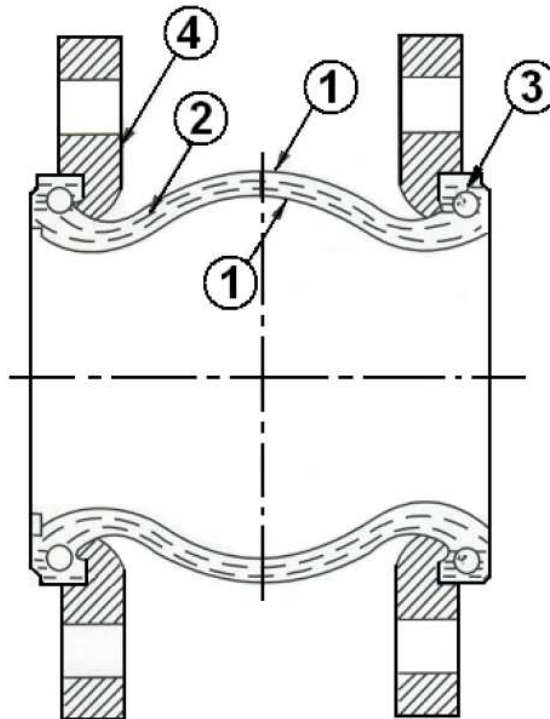

Item	Designation	Materials 1501 - 1502	Materials 1503
1	Inner tube and cover	EPDM	NBR
2	Reinforcement	Nylon cord	
3	Brace	Hard steel	
4	Flanges	Electro galvanized steel	

F8

F8.000.1503 PN16 DN32-DN600 Expansion joints rubber flange

SIZE (in mm) :

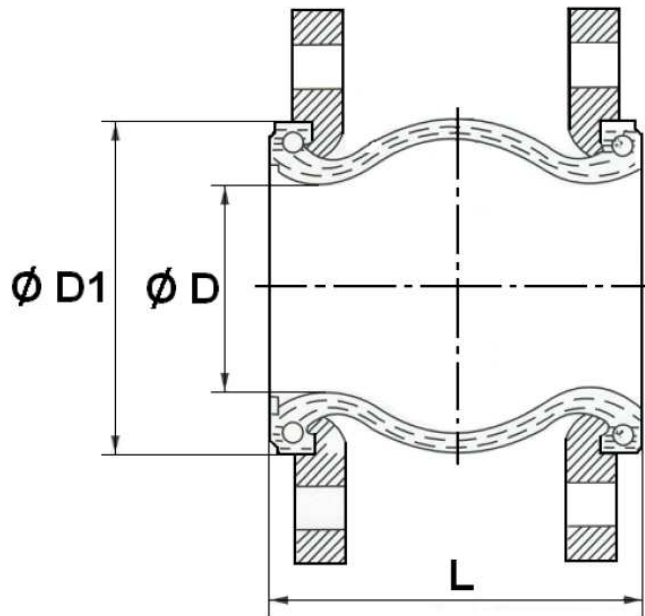

Ref.	DN	32	40	50	65	80	100	125	150	200	250	300	350	400	450	500	600
1501-1502	L	95	95	105	115	130	135	170	180	205	240	260	265	265	200	200	250
	$\varnothing D$	29	37	47	57	74	91	119	145	199	241	294	331	372	431	486	591
1503	$\varnothing D1$	69	79	90	108	124	145	179	209	261	320	370	420	473	532	587	685
1501	Weig. (Kg)	2.79	3.59	4.23	4.74	6.27	6.47	9.4	12.75	17.73	23.27	29.4	41.3	46.85	55.18	65	74.5
1502	Weig. (Kg)									17.87	26	33.13					
1503	Weig. (Kg)	2.95	3.46	3.98	4.89	6.57	6.74	9.36	12.71	16.80							

F8

F8.000.1503 PN16 DN32-DN600 Expansion joints rubber flange

FLANGES SIZE PN10 Ref.1501 and 1503 (in mm) :

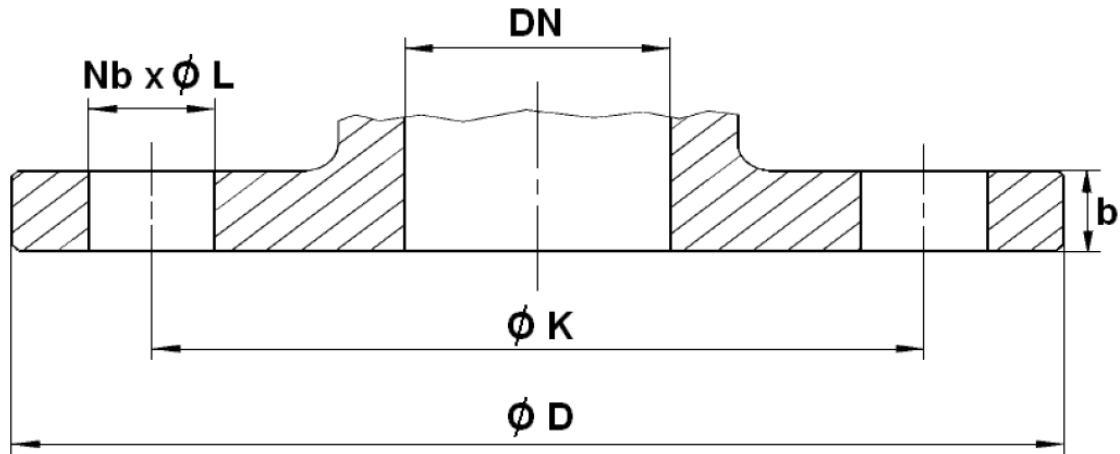

Ref.	DN	32	40	50	65	80	100	125	150	200	250	300
1501 1503	Ø D	140	150	165	185	200	220	250	285	340	395	445
	Ø K	100	110	125	145	160	180	210	240	295	350	400
	Nb x Ø L	4 x 19	4 x 19	4 x 19	4 x 19	8 x 19	8 x 19	8 x 19	8 x 23	8 x 23	12 x 23	12 x 23
	b	14	14	15	15	17	17	19	19	20	22	22

Ref.	DN	350	400	450	500	600
1501 1503	Ø D	505	565	615	670	780
	Ø K	460	515	565	620	725
	Nb x Ø L	16 x 23	16 x 28	20 x 28	20 x 28	20 x 31
	b	26	28	28	30	32

F8

F8.000.1503 PN16 DN32-DN600 Expansion joints rubber flange

FLANGES SIZE PN16 Ref.1502 (in mm) :

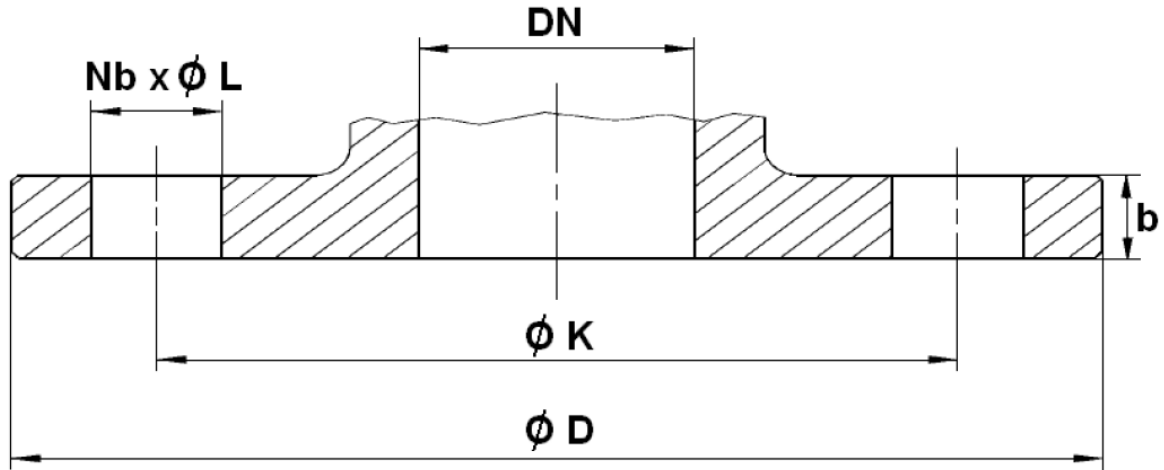

Ref.	DN	200	250	300
1502	Ø D	340	405	460
	Ø K	295	355	410
	Nb x Ø L	12 x 23	12 x 28	12 x 28
	b	22	24	24

MOVEMENTS (in mm) :

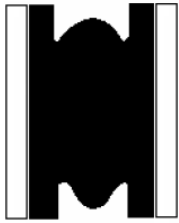

Compansion

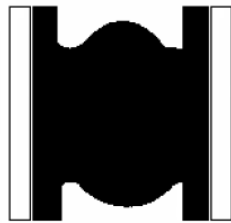

Expansion



Lateral

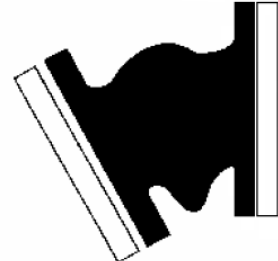

Angular

DN	32	40	50	65	80	100	125	150	200	250	300	350	400	450	500	600
Compansion	8	8	8	12	12	18	18	18	20	22	24	25	25	20	20	20
Expansion	4	4	4	6	10	10	10	10	14	14	14	16	16	12	12	12
Lateral	8	8	8	10	12	12	12	12	18	18	18	18	18	18	18	18
Angular	15°	15°	15°	15°	15°	15°	15°	15°	15°	15°	15°	15°	15°	15°	15°	15°

Maximum movements can't be applied together

STANDARDS :

- Fabrication according to ISO 9001 : 2015
- DIRECTIVE 2014/68/EU : Products excluded from directive (Article 4, § 3)
- Flanges according to EN 1092-1 PN10/16

INSTALLATION INSTRUCTION :

Expansion joint are designed for the absorption of previously specified movements under specific pressure and temperature conditions. So that the maximum service life is achieved, the following items must be observed during installation.

- Prior to fitment of the compensator it must be ensured that :
 - The route of the pipeline is straight - The expansion tallies with that of the chosen compensator
 - The expansion tallies with that of The chosen compensator
 - The fixes points are dimensionned so that they can absorb the reaction forces and stiffness rate that arise during use.
 - The pipeline is limited by fixed points
 - The distance between compensator and bearing may be a maximum of 3 times the pipe diameter. Place only one compensator between 2 bearings.
- Each pipe elbow must be fixed by support, specially if compensator is mounted with limiters. Fixed bearings are necessary because compensator is submitted to expansion when it is under pressure.
- Expansion joint must not be painted and heat-insulated. It must be protected from bad weather and solar radiation.
- During assembly operation, make sure screws are oriented according to the graph out below :

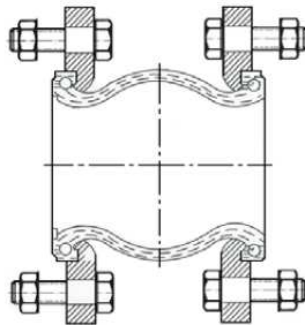

- Please apply the following stages order :
 - a) Fixed points for above pipeline
 - b) Fixed points for down pipeline
 - c) Compensator mounting
- Installation layout :

