

# D71

D71 118 540.235 PN40 DN15-200  
Y-strainer flanged



PED 2014/68/EU



Certificate 3.1

**Size :** DN 15 to DN 200  
**Ends :** Flanged R.F. PN25/40  
**Min Temperature :** - 29°C  
**Max Temperature :** + 425°C  
**Max Pressure :** 40 Bars  
**Specifications :** Stainless steel removable filter  
Bolted bonnet with draining cap

**Materials :** Carbon steel ASTM A216 WCB

# D71

## D71 118 540.235 PN40 DN15-200 Y-strainer flanged

### SPECIFICATIONS :

- Removable stainless steel filter
- R.F. Flanged PN25/40 , PN40 for DN200
- Horizontal or vertical position with descendant fluid (respect the flow direction indicated by the arrow)
- Mesh 1mm up to DN 50 , 1.25 mm from DN 65 to 80 and 1.6 mm over
- Bolted bonnet with draining cap threaded BSP
- Blue painting RAL 5002, 120 µm thickness

### USE :

- For all common fluids
- Min Temperature Ts : - 29°C
- Max Temperature Ts :+ 425°C
- Max Pressure Ps : 40 bars ( see graph )

### PRESSURE / TEMPERATURE RELATION ( STEAM EXCLUDED ) :

Temperature (°C)	-29	-10	120	200	250	300	350	400	425
Pressure (Bar)	25.8	40	40	34.7	31.4	28	24	21	18

### FLOW COEFFICIENT Kvs ( M3 / h ) :

DN	15	20	25	32	40	50	65	80	100	125	150	200
Kvs ( m3/h )	6.2	10.8	16.8	26.1	36.7	61	98.6	146	234	376	405	752

HEAD LOSS :

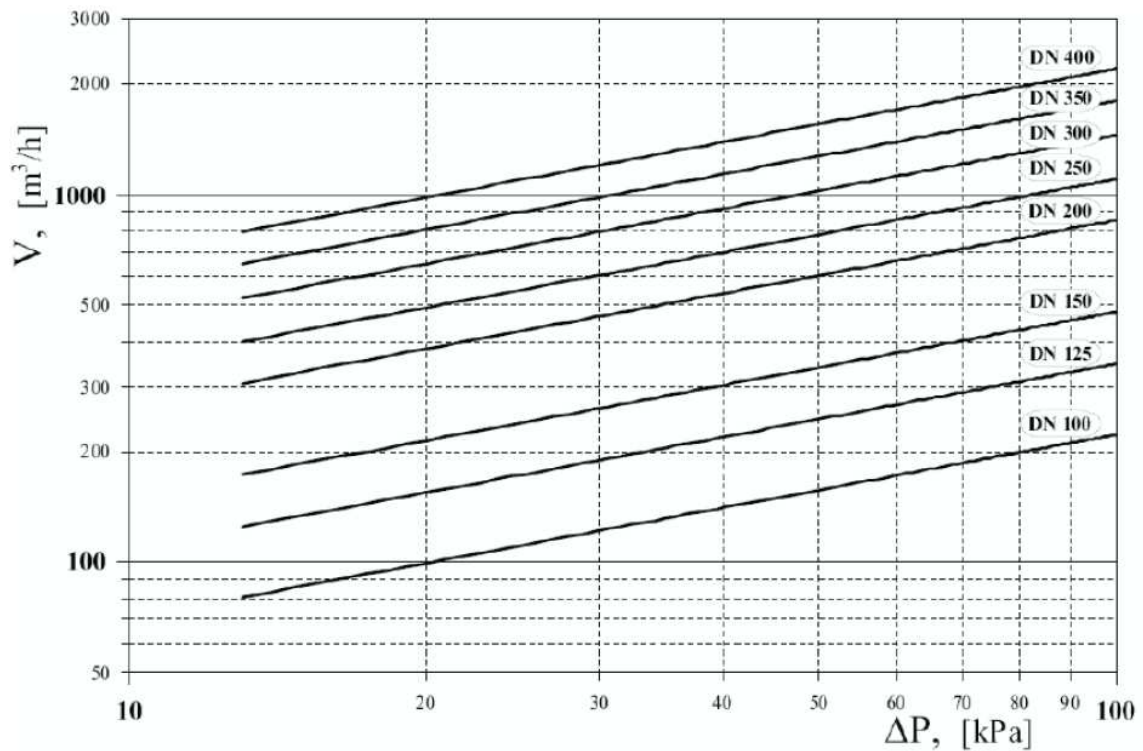
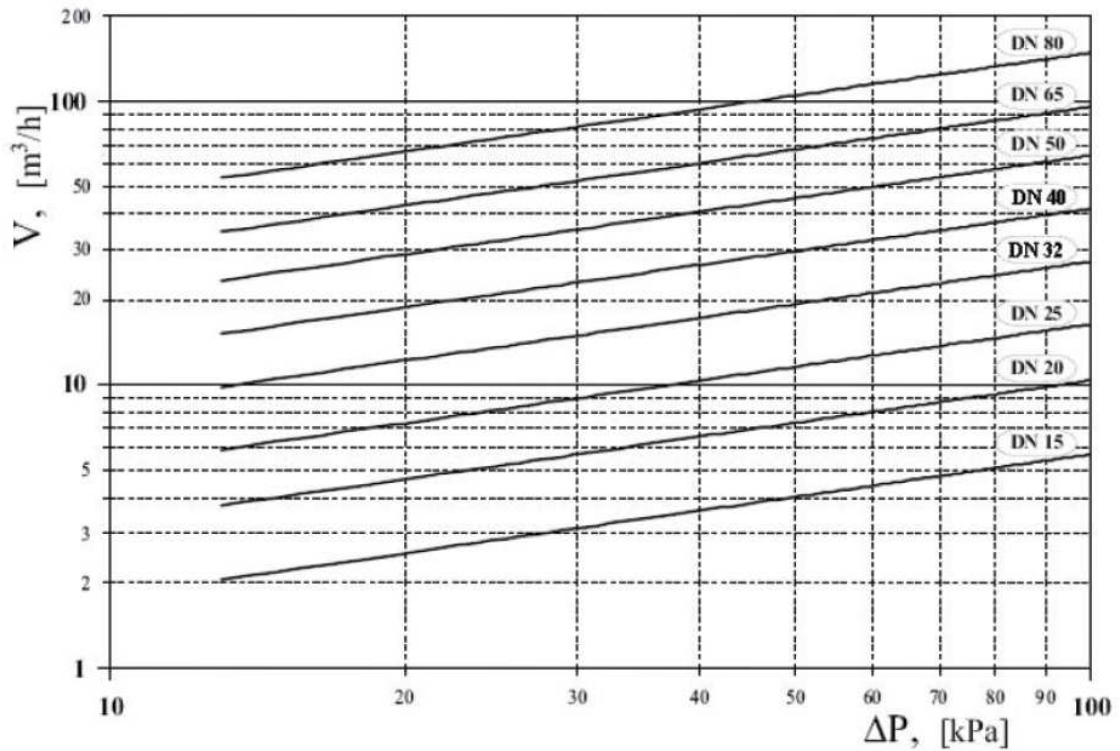

# D71

## D71 118 540.235 PN40 DN15-200 Y-strainer flanged

### RANGE :

- Carbon steel flanged R. F. PN25/40 DN 15 up to DN 150 and PN40 for DN200 Ref.235
- Carbon steel flanged male-female facing PN25/40 from DN 15 up to DN 80 Ref.2353

### MATERIALS :

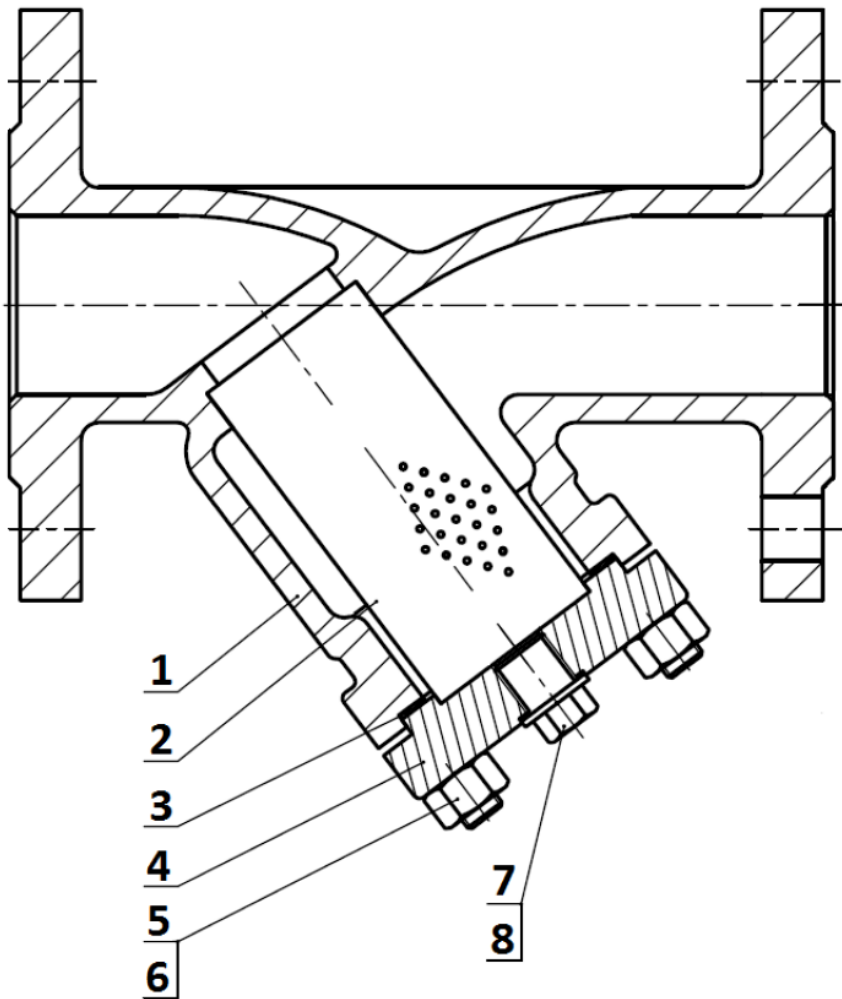

Item	Designation	Materials
1	Body	ASTM A 216 WCB
2	Filter	AISI 304
3	Bonnet gasket	Graphite
4	Bonnet	ASTM A216 WCB
5	Stud	A193-B7
6	Nut	A194-2H
7	Plug	A105
8	Plug gasket	Copper

# D71

## D71 118 540.235 PN40 DN15-200 Y-strainer flanged

SIZE ( in mm ) :

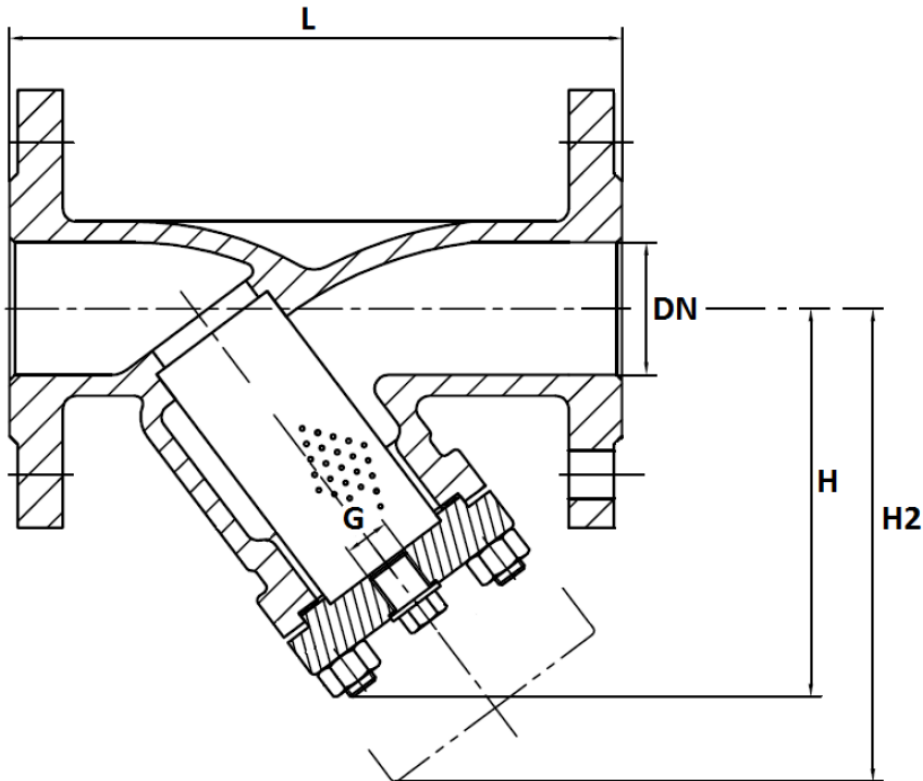

Filter size :

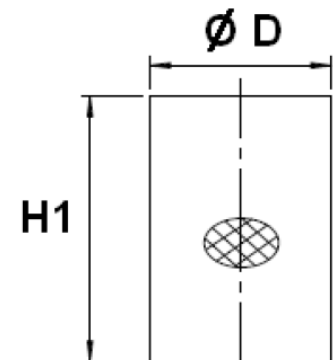

Ref.	DN	15	20	25	32	40	50	65	80	100	125	150	200
235	L	130	150	160	180	200	230	290	310	350	400	480	600
	H	98	97	108	113	138	147	170	204	240	288	334	380
	H2	106	115	122	130	155	165	190	225	265	310	360	427
	G (drain BSP)	3/8"	3/8"	3/4"	3/4"	1"	1"	1"	1"	1"1/2	1"1/2	1"1/2	1"1/2
	Ø D	22	22	29	35	42	52	58	75	104	124	150	190
	H1	48	59	75	85	97	105	121	150	175	205	240	310
	Mesh	1	1	1	1	1	1	1.25	1.25	1.6	1.6	1.6	1.6
	Weight (Kg)	2.8	3.4	4.9	6.6	8.9	11.3	15.8	20.6	32.1	47.9	66	135

# D71

## D71 118 540.235 PN40 DN15-200 Y-strainer flanged

FLANGES SIZE ( in mm ) :

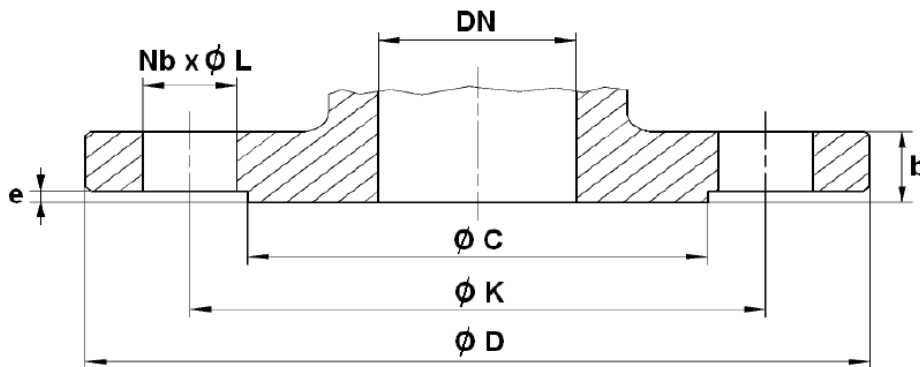

DN	15	20	25	32	40	50	65	80	100	125	150	200
$\phi C$	45	58	68	78	88	102	122	138	162	188	218	285
$\phi D$	95	105	115	140	150	165	185	200	235	270	300	375
$\phi K$	65	75	85	100	110	125	145	160	190	220	250	320
Nb x $\phi L$	4 x 14	4 x 14	4 x 14	4 x 18	4 x 18	4 x 18	8 x 18	8 x 18	8 x 22	8 x 26	8 x 26	12 x 30
b	16	18	18	18	18	20	22	24	24	26	28	34
e	2	2	2	2	3	3	3	3	3	3	3	3

# D71

## D71 118 540.235 PN40 DN15-200 Y-strainer flanged

### STANDARDS :

- Fabrication according to ISO 9001 : 2008
- Design according to DIN 3356
- DIRECTIVE 2014/68/EU : CE N° 0036  
Risk Category III Module H
- Certificate 3.1 on request
- Tests according to DIN 3230
- Length according to EN 558 series 1 (DIN 3202 – NF 29354)
- Flanges R.F. according to EN 1092-1 PN40

### INSTALLATION POSITIONS :

Vertical position ( descendand fluid )



Horizontal position

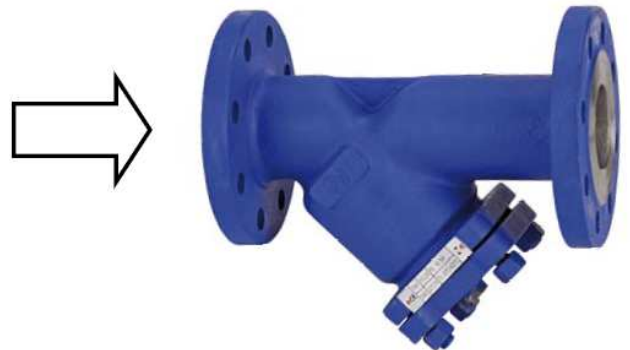

# D71

**D71 118 540.235 PN40 DN15-200  
Y-strainer flanged**

---

## **INSTALLATION INSTRUCTIONS**

### **GENERAL GUIDELINES :**

- Ensure that the strainers to be used are appropriate for the conditions of the installation (type of fluid, pressure and temperature).
- Be sure to have enough valves to be able to isolate the sections of piping as well as the appropriate equipment for maintenance and repair.
- Ensure that the strainers to be installed are of correct strength to be able to support the capacity of their usage.
- **Installation of all circuits should ensure that their function can be automatically tested on a regular basis (at least two times a year).**

### **INSTALLATION INSTRUCTIONS :**

- **Before installing the strainers, clean and remove any objects from the pipes** (in particular bits of sealing and metal) which could obstruct and block the strainers.
- **Ensure that both connecting pipes either side of the strainer (upstream and downstream) are aligned (if they're not, the strainer may not work correctly).**
- **Make sure that the two sections of the pipe (upstream and downstream) match, the strainer unit will not absorb any gaps. Any distortions in the pipes may affect the tightness of the connection, the working of the strainer and can even cause a rupture. To be sure, place the kit in position to ensure the assembling will work.**
- Make sure flanges are cleaned.
- **If sections of piping do not have their final support in place, they should be temporarily fixed. This is to avoid unnecessary strain on the strainer.**
- Tighten the bolts in cross.
- The pressurisation must be increased gradually.
- So that the maintenance operations could be easily done, place a stop valve before and after the strainer. Thereby, the strainer could be isolated. During this operation, ensure to have a new bonnet gasket to avoid a leakage during the restarting.
- **Fluids in the strainer must not contain solid objects ( it could damaged the seat ).**