

L32

L32.5.1121 PN16 DN32-300 Butterfly valve wafer



Certificate 3.1

Size : DN 32/40 to DN 300
Ends : Between flanges PN6,PN10/16,Class 150,JIS10K*
Min Temperature : -10°C
Max Temperature : + 80°C
Max Pressure : 16 Bars
Specifications : Long neck for isolation
Stainless steel disc
NBR vulcanized seat

Materials : Cast iron body

SPECIFICATIONS :

- Long neck for isolation
- ISO 5211 mounting pad
- Wafer type
- Between flanges PN6 from DN40 to 150 and for DN300, PN10/16 from DN32 to 300, Class 150 (PN20) and JIS10K from DN40 to 300
- Full crossing stem
- With 10 positions lever and locking device up to DN150
- Double PTFE gasket on stem
- Stainless steel disc
- Epoxy painting RAL003 80 microns thickness
- Vulcanized NBR seat

USE :

- No aromatic hydrocarbon, fuel, water, natural gas, grease, oil, compressed air, glycol
- Min and max Temperature Ts : - 10°C to + 80°C
- Max Pressure Ps : 16 bars

FLOW COEFFICIENT Kv (M3 / h) :

DN	32/40	50	65	80	100	125	150	200	250	300	
Opening angle	10°	0,04	0,05	0,09	0,17	0,26	0,43	0,68	1,7	2,6	3,4
	20°	2	3	5	8	15	25	38	76	129	200
	30°	5	6	10	15	31	52	81	160	273	422
	40°	10	13	21	33	67	113	175	348	592	914
	50°	18	23	38	60	119	202	312	620	1055	1630
	60°	30	38	64	99	196	334	516	1025	1746	2697
	70°	48	60	102	156	310	529	817	1623	2764	4269
	80°	72	90	152	235	466	793	1226	2434	4145	6403
	90°	78	98	167	258	512	872	1347	2675	4555	7037

TORQUE VALUE (Nm, without safety coefficient) :

We recommend a safety coefficient of 30% minimum to determinate the actuator.

DN	32/40	50	65	80	100	125	150	200	250	300
PN10	11	15	24	31	48	73	106	177	281	410
PN16	12	16	26	33	53	81	119	194	308	441

L32

L32.5.1121 PN16 DN32-300 Butterfly valve wafer

RANGE :

- With lever from DN32/40 to DN300
- Gear box possible (Ref.1198) from DN32/40 to DN300

MATERIALS :

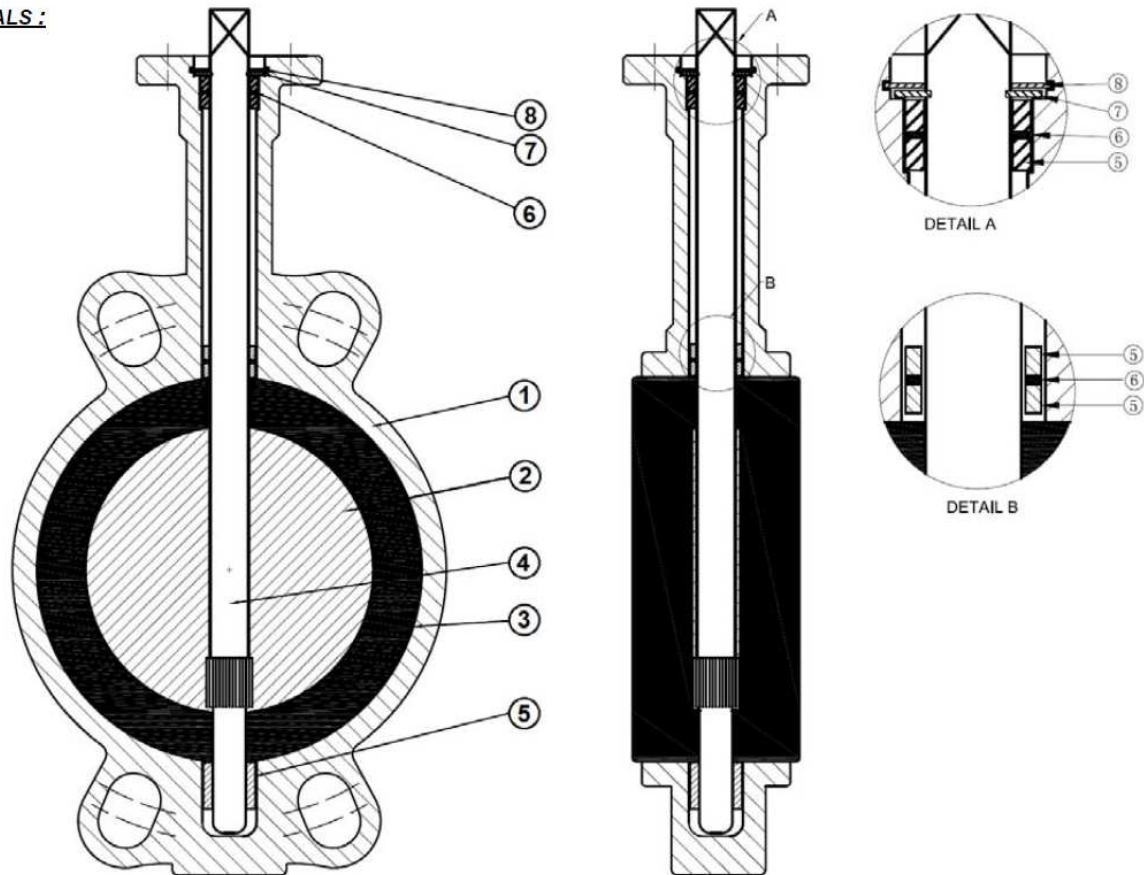

Item	Designation	Materials
1	Body	Cast iron EN GJL-250
2	Disc	ASTM A351 CF8M
3	Seat	NBR
4	Stem	AISI 416
5	Bushing	PTFE
6	O ring	NBR
7	Circlip	Steel
8	Circlip	Steel
	Lever	Aluminium

MATERIALS GEARBOX :

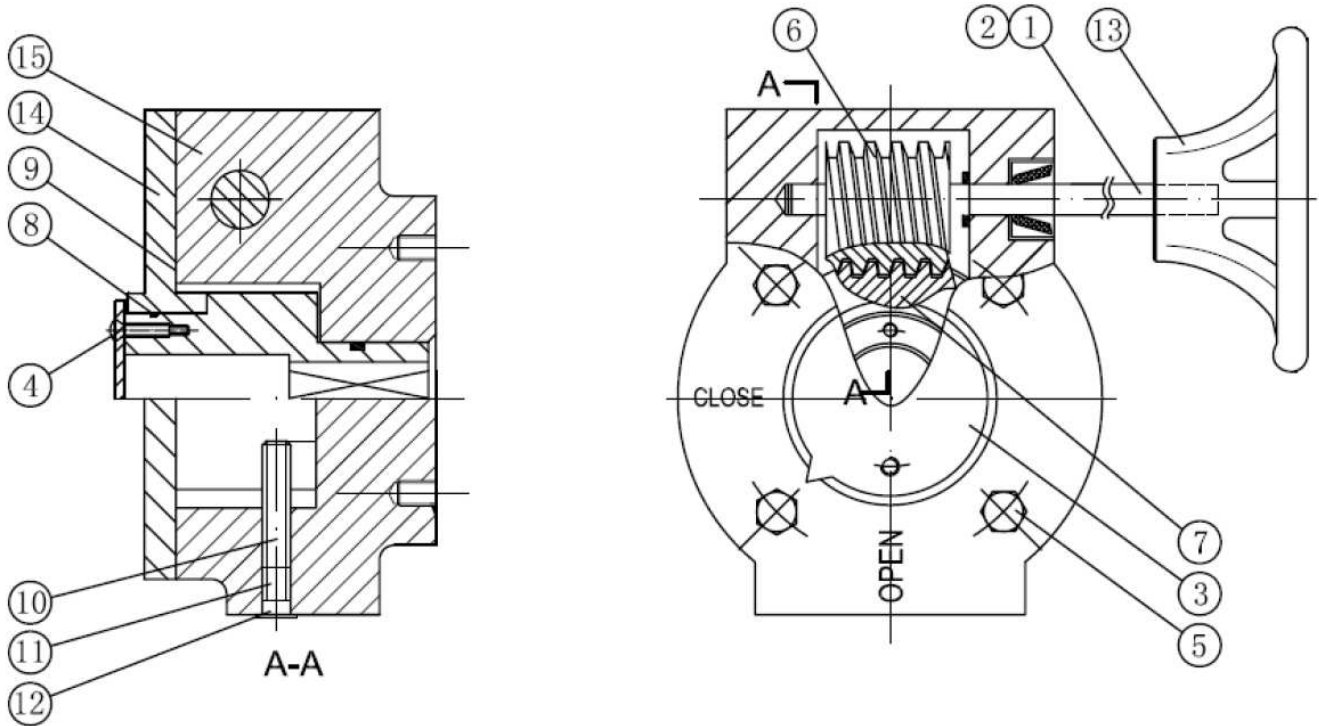

Item	Designation	Materials
1	Stem	Chromed steel
2	Pin	AISI 316
3	Indicator plate	Aluminium + NBR gasket
4	Indicator bolt, washer	AISI 316
5	Bolt, washer	AISI 316
6	Gear 1	Steel
7	Gear 2	Ductile iron EN GJS-400-15
8	O ring	NBR
9	Bonnet gasket	NBR
10	Internal set screw	Carbon steel
11	External set screw	AISI 316
12	Plastic cap	Plastic
13	Handwheel	Cast iron EN GJL-250 epoxy coating
14	Bonnet	Cast iron EN GJL-250 epoxy coating
15	Body	Cast iron EN GJL-250 epoxy coating
	Bolting to fix on valve	AISI 304

L32

L32.5.1121 PN16 DN32-300 Butterfly valve wafer

VALVES SIZE (in mm) :

- VALVES WITH LEVER DN 32/40 - 300 :

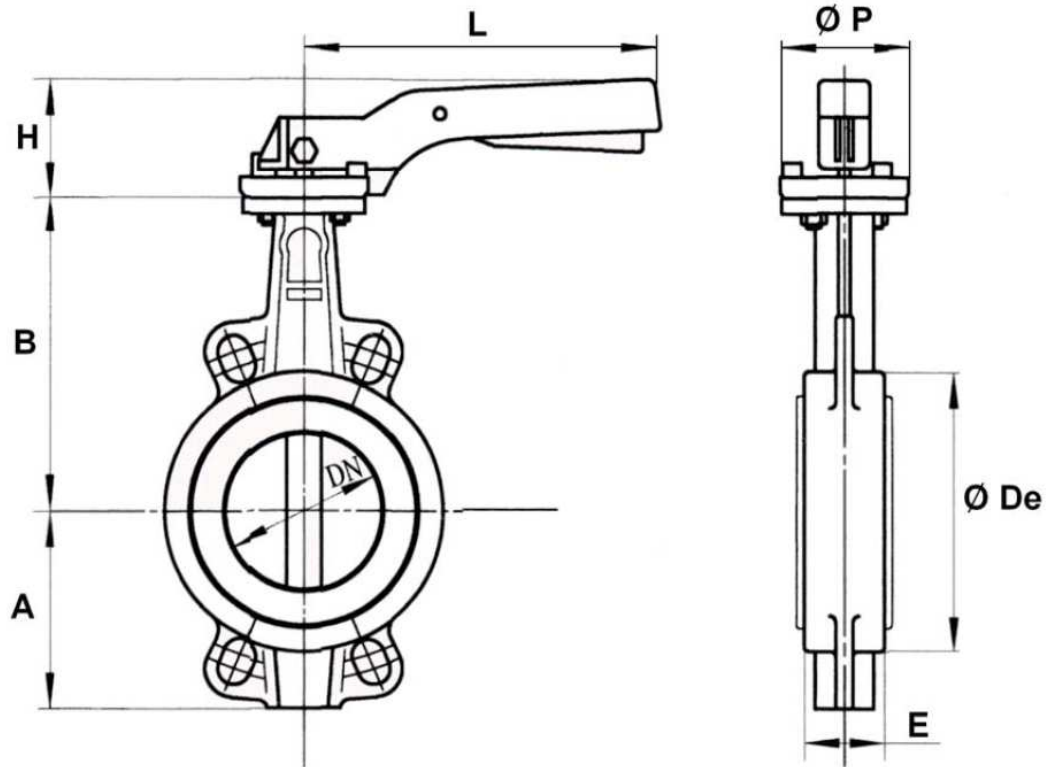

Ref.	DN	32/40	50	65	80	100	125	150	200	250	300
1121	A	61	77	87,5	95	107	121,5	144	171	205	235
	B	130	136,5	142	158	180	192	215	242	280	310
	Ø De	82	95	109	121	152	180	207	260	315	370
	E	33	43	46	46	52	56	56	60	68	78
	H	70	70	70	70	70	71	71	40	44	44
	L	195	195	195	195	195	278	278	355	507	507
	Ø P	65	65	65	65	65	90	90	125	150	150
	Weig. (Kg)	1.85	2.53	2.86	3.16	4.21	6.67	7.66	14.67	23.4	33.8

L32

L32.5.1121 PN16 DN32-300 Butterfly valve wafer

GEAR BOX SIZE (in mm) :

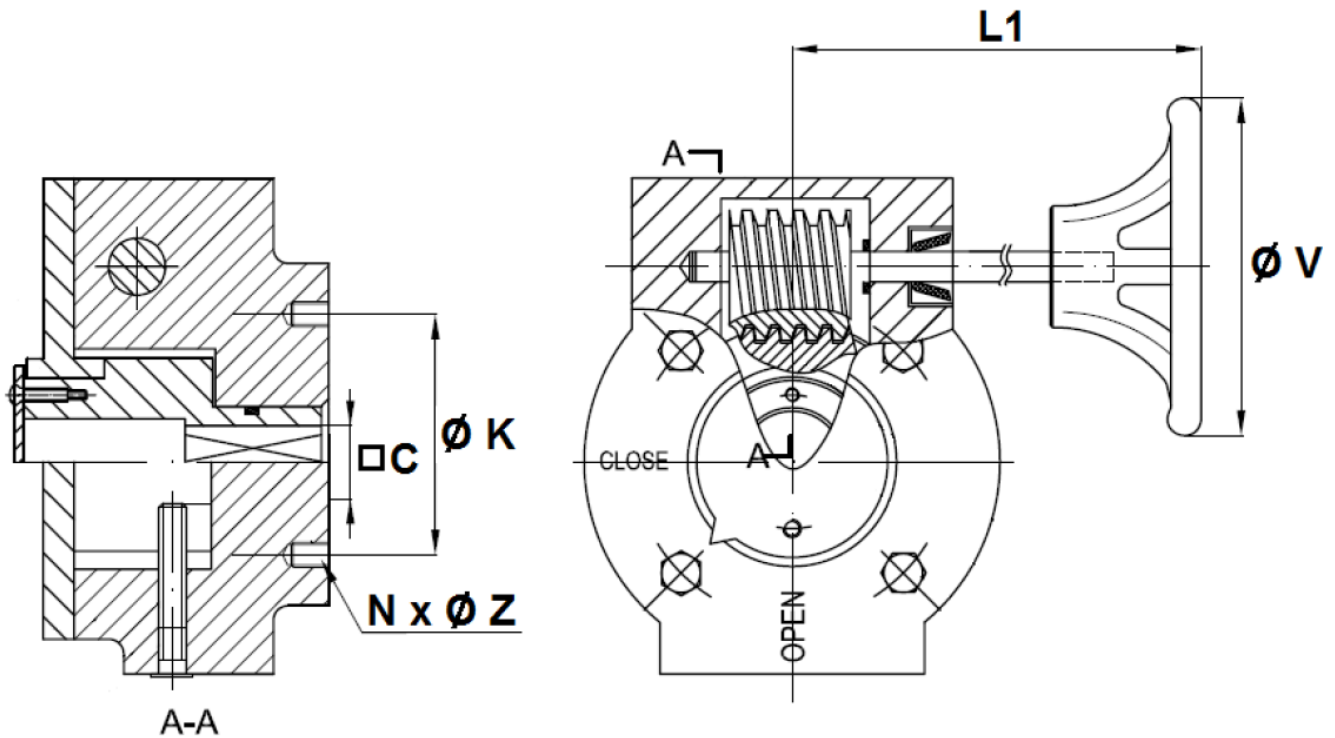

DN	32/80	100	125/150	200	250	300
C	9	11	14	17	22	27
Ø K	50	50	70	102	125	125
ISO	F05	F05	F07	F10	F12	F12
Nx ØZ	4 x M6	4 x M6	4 x M8	4 x M10	4 x M12	4 x M12
L1	156	156	156	241	223	223
Ø V	150	150	250	300	300	300
Weight (kg)	3.51	4.22	3.53	6.99	7.42	9.6
Ref.	1198001	1198002	1198003	1198004	1198005	1198006

L32

L32.5.1121 PN16 DN32-300 Butterfly valve wafer

DISC AND NECK SIZE (in mm) :

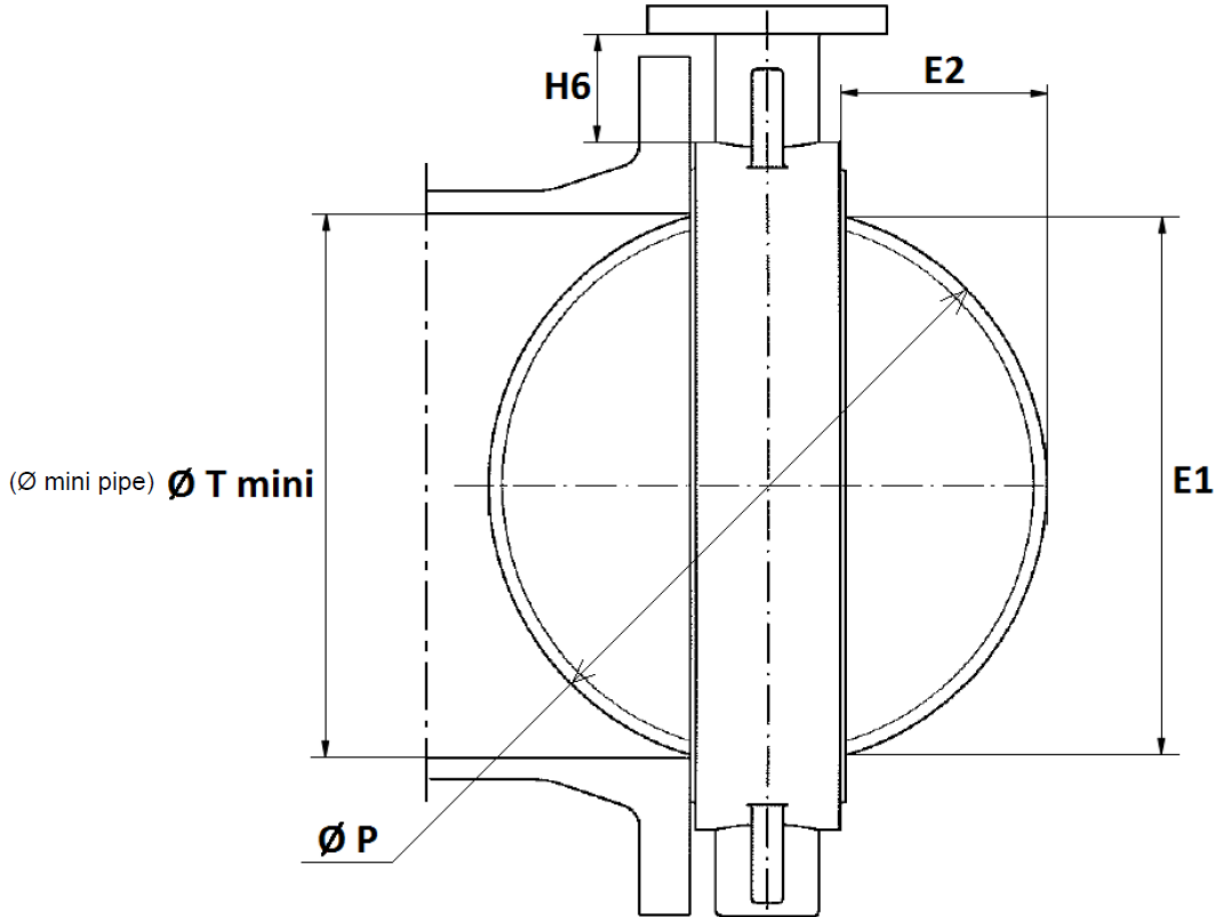

DN	40	50	65	80	100	125	150	200	250	300
E1	37.7	47.06	59.81	75.56	98.37	117.02	147.65	195.3	242.5	292.6
E2	4.9	5	9.4	16.5	26.1	33.9	49.7	71.2	91.2	111.8
H6 ± 2	76.7	79	79	87.5	92.3	90.3	99.2	99.5	103.8	105.8
$\varnothing P$	42.8	53	64.8	79.1	104.25	123.8	155.4	202.4	250.5	301.6
$\varnothing T \text{ mini}$	43	53	65	79.5	104.5	124	155.5	202.5	250.5	302

L32

L32.5.1121 PN16 DN32-300 Butterfly valve wafer

ISO MOUNTING PAD SIZE (in mm) :

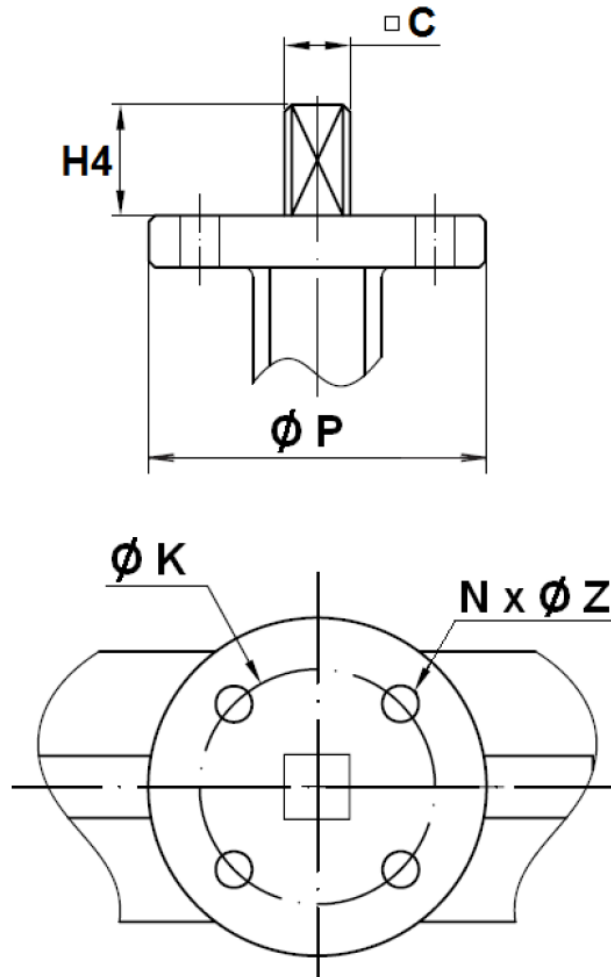

DN	32/40	50	65	80	100	125	150	200	250	300
C	9	9	9	9	11	14	14	17	22	27
Ø K	50	50	50	50	50	70	70	102	125	125
ISO	F05	F05	F05	F05	F05	F07	F07	F10	F12	F12
Nx ØZ	4 x 7	4 x 7	4 x 7	4 x 7	4 x 7	4 x 9	4 x 9	4 x 11	4 x 13	4 x 13
H4	32	32	32	32	32	42	42	36	38	38
Ø P	65	65	65	65	65	90	90	125	150	150

GEARBOX SPECIFICATIONS :

DN	32/80	100	125/150	200	250	300
Ref.	1198001	1198002	1198003	1198004	1198005	1198006
Ratio factor	24 :1	24 :1	24 :1	30 :1	30 :1	50 :1
Input torque (Nm)	18	18	18	58	58	60
Output torque (Nm)	170	170	170	700	700	1200

STANDARDS :

- Fabrication according to ISO 9001 : 2015
- Designing according to API 609
- DIRECTIVE 97/23/CE : CE N° 0035
Risk category III module H
- Certificate 3.1 on request
- Pressure tests according to API 598, table 6
- Length according to ISO 5752 series 20, EN 558 series 20 (NF 29305)
- ISO 5211 mounting pad
- Between flanges according to EN 1092-1 PN6-PN10/16 and ASME B16.5 Class 150 (PN20)

INSTALLATION INSTRUCTIONS

GENERAL GUIDELINES :

- Ensure that the valves to be used are appropriate for the conditions of the installation (type of fluid, pressure and temperature).
- Be sure to have enough valves to be able to isolate the sections of piping as well as the appropriate equipment for maintenance and repair.
- Ensure that the valves to be installed are of correct strength to be able to support the capacity of their usage.
- **Installation of all circuits should ensure that their function can be automatically tested on a regular basis (at least two times a year).**

INSTALLATION INSTRUCTIONS :

- Before installing the valves, clean and remove any objects from the pipes (in particular bits of sealing and metal) which could obstruct and block the valves.
- Ensure that both connecting pipes either side of the valve (upstream and downstream) are aligned (if they're not, the valves may not work correctly).
- Make sure that the two sections of the pipe (upstream and downstream) match, the valve unit will not absorb any gaps. Any distortions in the pipes may affect the tightness of the connection, the working of the valve and can even cause a rupture. To be sure, place the kit in position to ensure the assembling will work.
- If sections of piping do not have their final support in place, they should be temporarily fixed. This is to avoid unnecessary strain on the valve.
- The valve must be inserted between flanges with disc half opened but the disc must not overpass the valve thickness. Position the bolts to keep centered the valve. Then open fully the valve and tighten the bolts. See graph under.

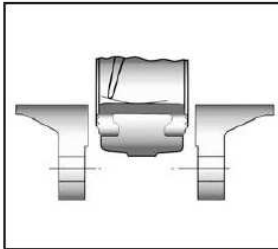

Half open valve introduction

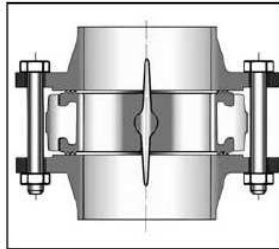

Complete opened disc valves
when screw tightening

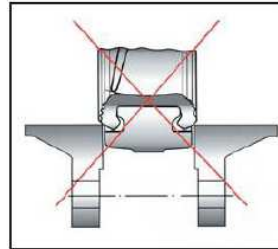

- Tighten the bolts in cross.
- The disc must move easily inside the pipe.
- Valves must be opened during cleaning operation.
- Tests must be done with a cleaned pipe.
- Tests must be done with opened valve. Test pressure must not be higher than the valve specification according to API 598.
- Then open slowly the valve.
- **Do not mount butterfly valves with stainless steel pressed collars and turning flanges without strias.**
- **And not on flat face flanges without strias (example : painted cast iron fittings)**

MAINTENANCE :

- We recommend to operate fully the valve 1 to 2 times per year.
- During maintenance operation, ensure that the pipe isn't under pressure, that there's no fluid in the pipe and that the valve is isolated. If there's a fluid in the pipe, evacuate it. Ensure that there are no risks due to the temperature or the fluid (like acids). If the fluid is corrosive, inert the installation before maintenance operation.