

L32

L32.5.1141 PN16 DN32-200 Butterfly valve wafer



Certificate 3.1

Size : DN 32/40 to 200 mm
Ends : Between PN10/16 and Class 150 (PN20) flanges
Min Temperature : - 20°C
Max Temperature : + 60°C
Max Pressure : 5 Bars
Specifications : Long neck for isolation
Wafer type
Full crossing stem
ISO 5211 mounting pad

Materials : Ductile iron EN GJS 500-7 body, NBR Gas seat

*the installation defects and wear defects are not covered by the guarantee

L32

L32.5.1141 PN16 DN32-200 Butterfly valve wafer

SPECIFICATIONS :

- Long neck for isolation
- ISO 5211 mounting pad
- Wafer type
- Between flanges PN10/16 from DN32/40 to 200 and Class 150 (PN20) from DN40 to 200
- **NF ROBGAZ** certificate
- Full crossing stem
- Removable NBR Gas seat
- Stainless steel disc up to DN100 included and ductile iron disc epoxy coated +/- 40 µ from DN125 to 200
- 9 positions lever with locking device
- Rilsan coated body color RAL 5024 , 250-300 microns thickness

USE :

- Fluids : Gas
- Min and max Temperature Ts : - 20°C to + 60°C
- Max Pressure Ps : 5 bars (MOP 5 class)

RANGE :

- With lever from DN 32/40 to DN 200

ENDS :

- Between flanges PN10/16 from DN32/40 to 200 and Class 150 (PN20) from DN40 to 200

TORQUE VALUES (in Nm with safety coefficient of 30 % included) at 10 Bars :

DN	32/40	50	65	80	100	125	150	200
Torque (Nm)	8	10	14	18	31	59	93	206

L32

L32.5.1141 PN16 DN32-200 Butterfly valve wafer

FLOW COEFFICIENT Kv (m³ / h) :

DN	Opening Angle								
	10°	20°	30°	40°	50°	60°	70°	80°	90°
32-40	3	5	10	16	22	31	36	36	36
50	3	7	15	33	44	48	54	54	54
65	6	10	21	40	57	86	102	102	102
80	7	16	37	56	84	182	246	246	246
100	9	22	51	88	134	187	255	336	336
125	21	33	91	153	232	331	468	560	560
150	45	69	149	281	302	597	822	1015	1072
200	55	131	254	420	631	904	1388	1758	1758

HEAD LOSS CALCULATIONS :

$$\Delta p = (Q / K_v)^2 \times SG$$

Q : flow in m³/h

Δp : Head loss in bar

SG : Specific gravity (= 1 for water)

Kv : Volume of water in m³/h, that will flow through a given restriction or valve opening with a pressure drop of 1 bar at 20°C)

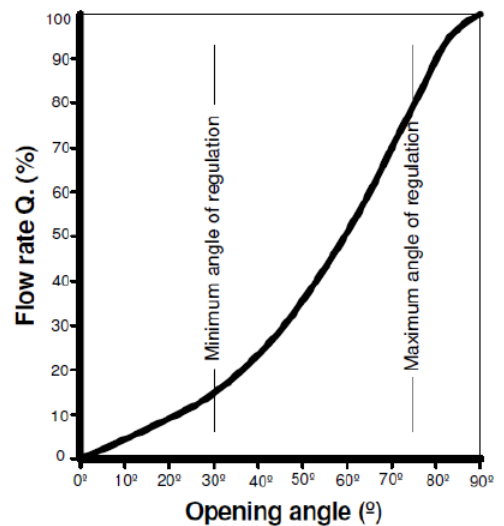

L32

L32.5.1141 PN16 DN32-200 Butterfly valve wafer

MATERIALS :

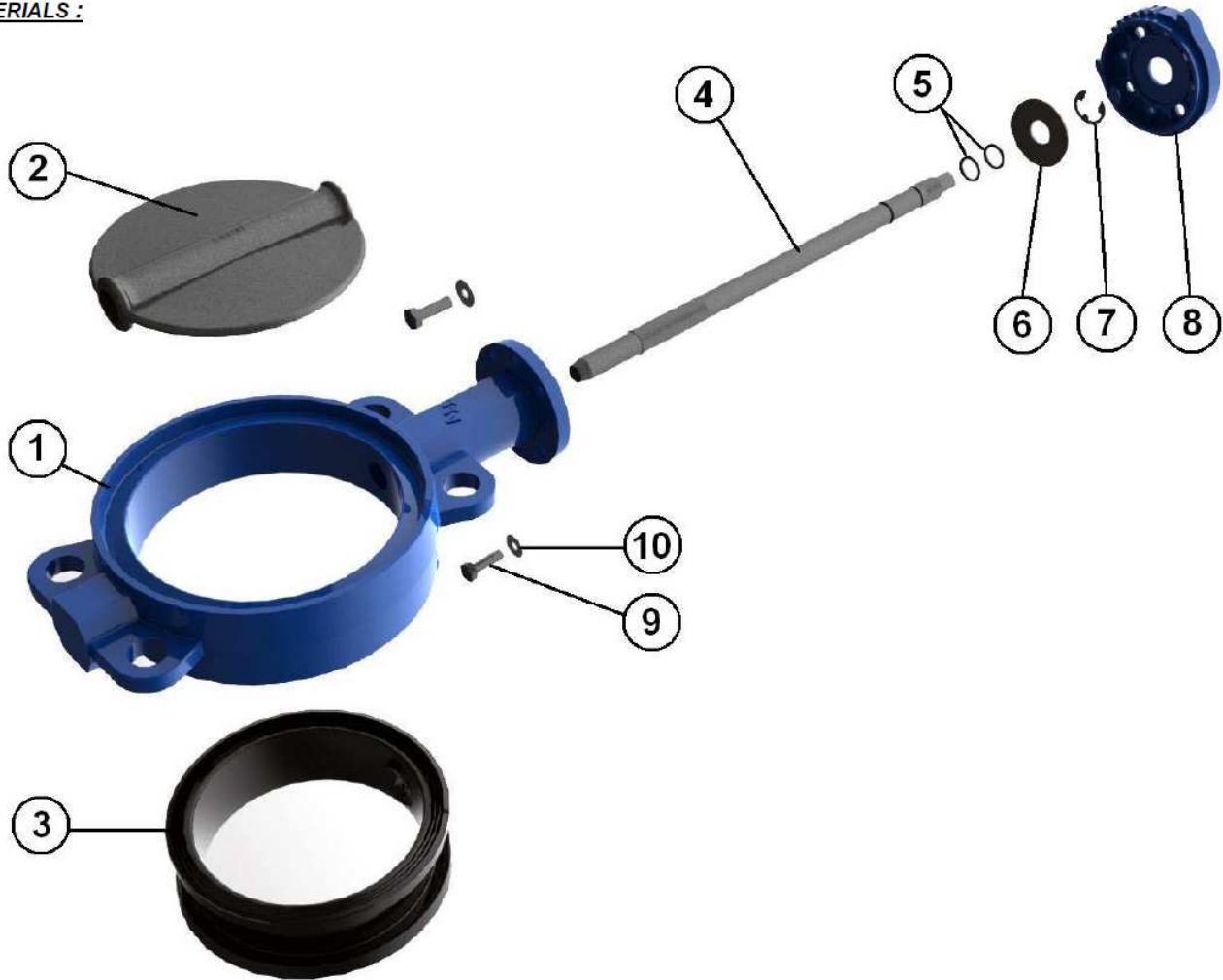

Item	Designation	Materials
1	Body	Ductile iron EN GJS-500-7 rilsan coated color RAL 5024 , 250-300 μ thickness
2	Disc DN40-100	ASTM A351 CF8M
2	Disc DN125-200	EN GJS 500-7 epoxy coated
3	Seat	NBR for Gas
4	Stem	AISI 420
5	O ring	NBR
6	Ring	Steel
7	Circlips	Steel
8	Plate	Aluminium
9	Plate screw	5.6
10	Washer	Steel
	Lever	Aluminium ADC10 with epoxy painting 50 μ thickness

L32

L32.5.1141 PN16 DN32-200 Butterfly valve wafer

SIZE (in mm) :

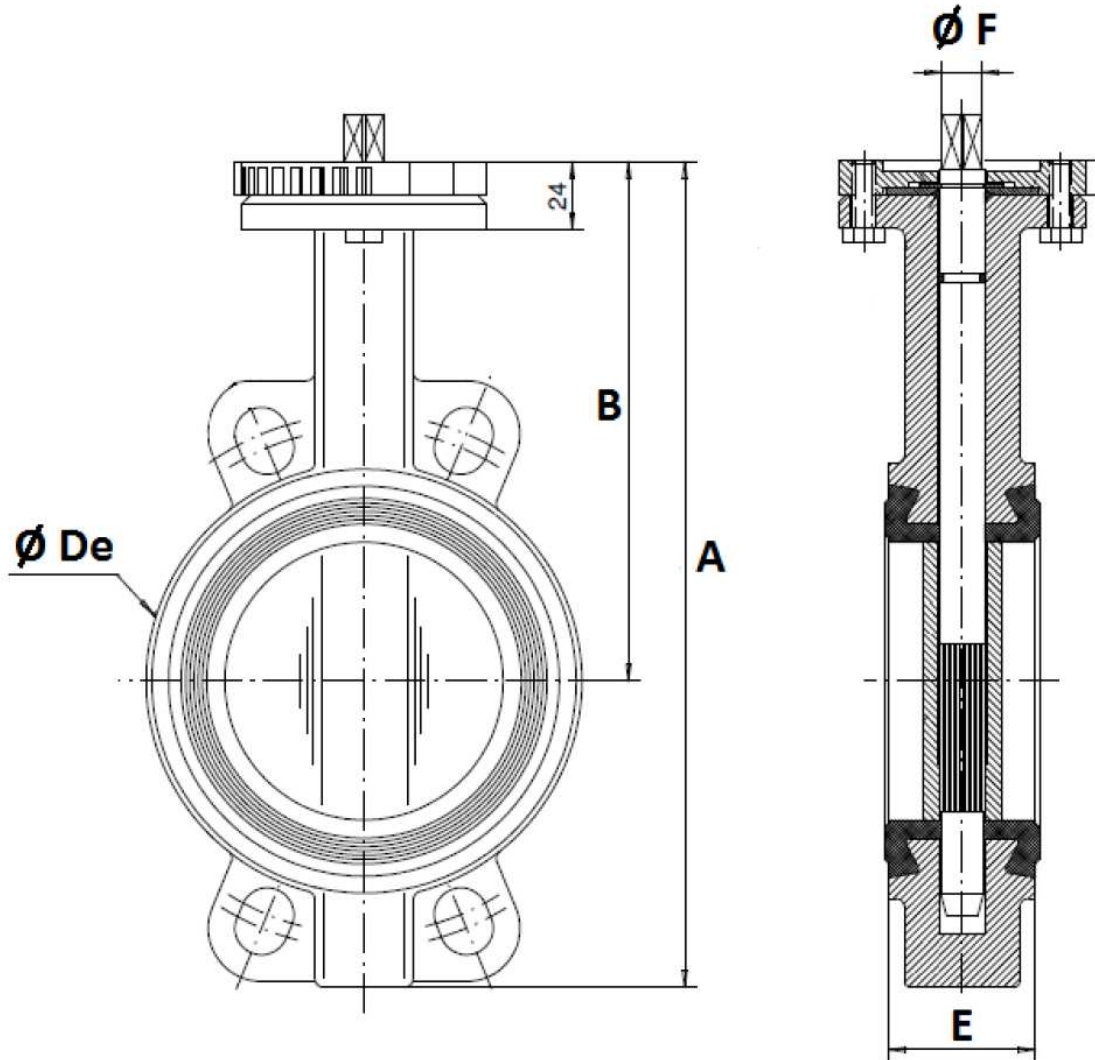

DN	32/40	50	65	80	100	125	150	200
A	206	228	248	265	298	331	349	430
B	140	156	161	169	187	206	215	255
Ø De	82	102	119	135	155	185	208	270
E	33	43	46	46	52	56	56	60
Ø F	9.5	9.5	12	14	14	17	17	21
Weight (Kg)	2.46	3.66	4.4	4.6	6	7.6	9.2	14.7

L32

L32.5.1141 PN16 DN32-200 Butterfly valve wafer

LEVERS SIZE (in mm) :

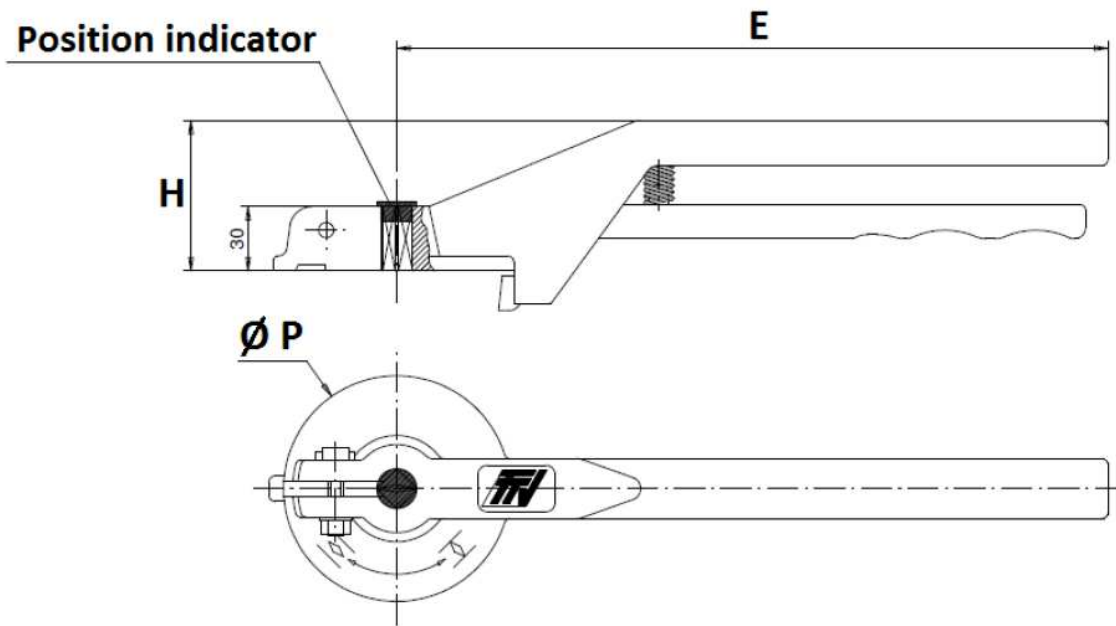

DN	32-100	125-200
E	205	330
H	57	70
Ø P	88	105

L32

L32.5.1141 PN16 DN32-200 Butterfly valve wafer

DISC AND NECK SIZE (in mm) :

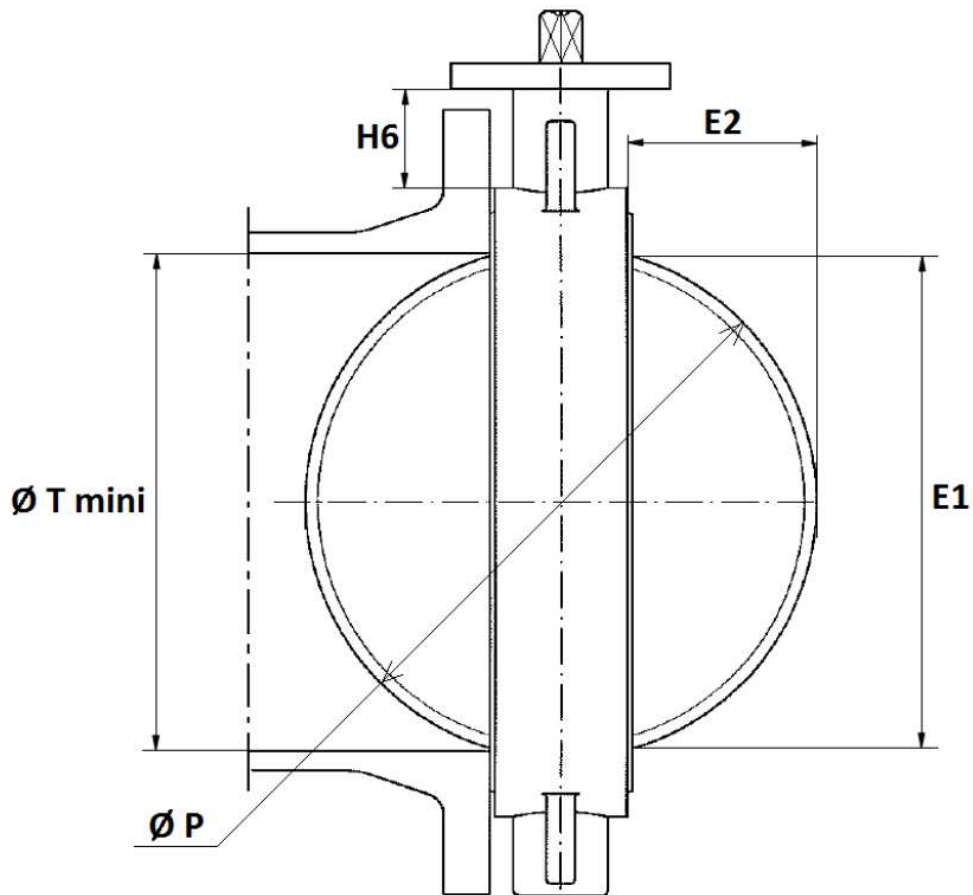

DN	32/40	50	65	80	100	125	150	200
E1	23	24.5	46	65	85	109	136	188
E2	3.5	3.5	9.5	17	24	33.5	45.5	69
H6	76	82	80	80	88	93	89	99
Ø T mini	26	27.5	49	68	88	112	139	191
Ø P	40	50	65	80	100	123	147	198

L32

L32.5.1141 PN16 DN32-200 Butterfly valve wafer

ISO MOUNTING PAD AND STEM SIZE (in mm) :

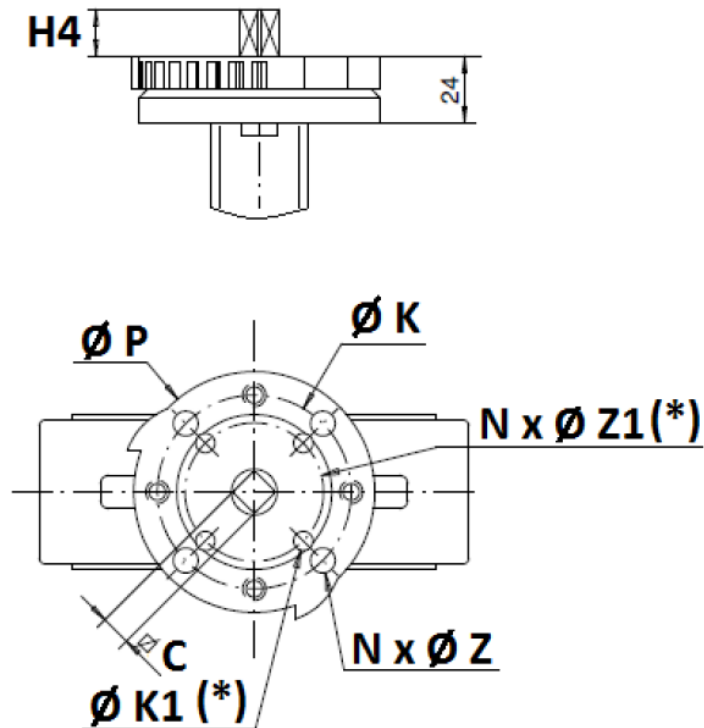

(*) : Only from DN32 to DN100

DN	32/40	50	65	80	100	125	150	200
H4	14	14	16	16	20	20	20	24
C	8	8	9	11	11	14	14	17
Ø K	70	70	70	70	70	70	70	70
ISO	F07	F07	F07	F07	F07	F07	F07	F07
N x Ø Z	4 x 9	4 x 9	4 x 9	4 x 9	4 x 9	4 x 9	4 x 9	4 x 9
Ø K1	50	50	50	50	50	-	-	-
ISO 1	F05	F05	F05	F05	F05	-	-	-
N x Ø Z1	4 x 7	4 x 7	4 x 7	4 x 7	4 x 7	-	-	-

L32

L32.5.1141 PN16 DN32-200 Butterfly valve wafer

BETWEEN FLANGES SIZE (in mm) :

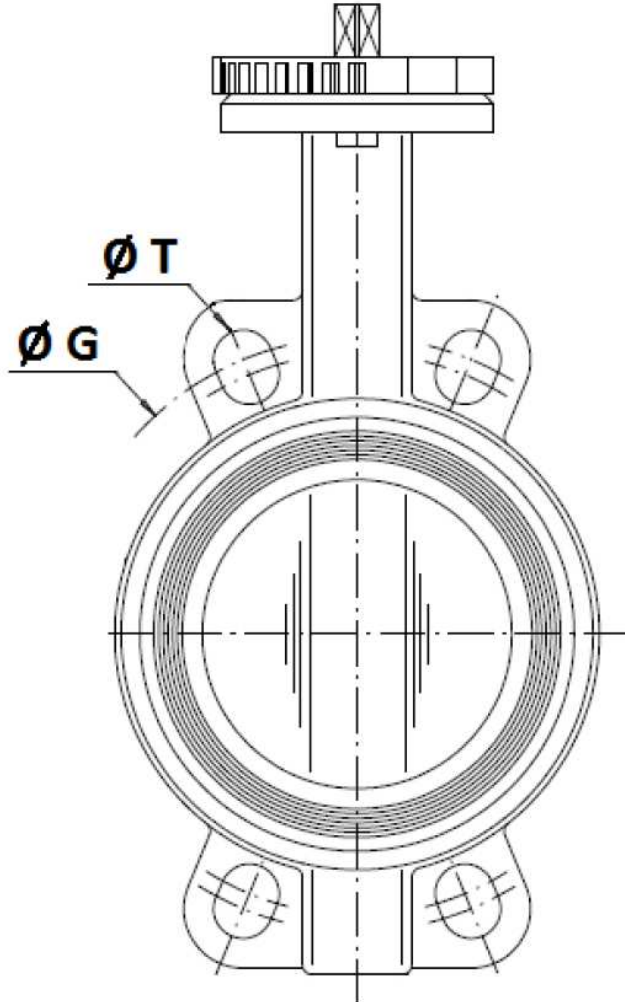

	DN (mm)	32	40	50	65	80	100	125	150	200
	NPS (")	1"1/4	1"1/2	2"	2"1/2	3"	4"	5"	6"	8"
PN10	Ø G	100	110	125	145	160	180	210	240	295
	Ø T	18	18	18	18	18	18	18	23	23
PN16	Ø G	100	110	125	145	160	180	210	240	295
	Ø T	18	18	18	18	18	18	18	23	23
Class 150	Ø G	88.9	98.5	120.6	139.7	152.4	190.5	215.9	241.3	298.5
	Ø T	16	16	19	19	19	19	23	23	23

STANDARDS :

- Fabrication according to ISO 9001:2008
- DIRECTIVE 2014/68/EU : CE N° 0038
Risk Category III module H
- Certificate 3.1 on request
- Pressure tests according to ISO 5208 , rate A
- Between PN10/16 flanges according to EN 1092-1
- ISO 5211 mounting pad
- Length according to ISO 5752 short series 20, EN 558 series 20 (NF 29305),BS 5155 Wafer short/medium, DIN 3202 part 3, series K1
- ATEX Group II Category 2 G/2D Zone 1 & 21 Zone 2 & 22 (optional marking)
- Certificate NF ROGAZ N° ROB 064-R5 according to NF EN 13774 & NF EN 549

INSTALLATION INSTRUCTIONS

GENERAL GUIDELINES :

- Ensure that the valves to be used are appropriate for the conditions of the installation (type of fluid, pressure and temperature).
- Be sure to have enough valves to be able to isolate the sections of piping as well as the appropriate equipment for maintenance and repair.
- Ensure that the valves to be installed are of correct strength to be able to support the capacity of their usage.
- **Installation of all circuits should ensure that their function can be automatically tested on a regular basis (at least two times a year).**

INSTALLATION INSTRUCTIONS :

- **Before installing the valves, clean and remove any objects from the pipes** (in particular bits of sealing and metal) which could obstruct and block the valves.
- **Ensure that both connecting pipes either side of the valve (upstream and downstream) are aligned (if they're not, the valves may not work correctly).**
- **Make sure that the two sections of the pipe (upstream and downstream) match, the valve unit will not absorb any gaps. Any distortions in the pipes may affect the tightness of the connection, the working of the valve and can even cause a rupture. To be sure, place the kit in position to ensure the assembling will work.**

INSTALLATION INSTRUCTIONS (SUITE):

- If sections of piping do not have their final support in place, they should be temporarily fixed. This is to avoid unnecessary strain on the valve.
- The valve must be inserted between flanges with disc half opened but the disc must not overpass the valve thickness. Position the bolts to keep centered the valve. Then open fully the valve and tighten the bolts.
See graph under.

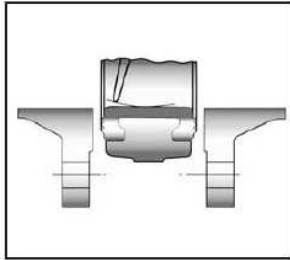

Half open valve introduction

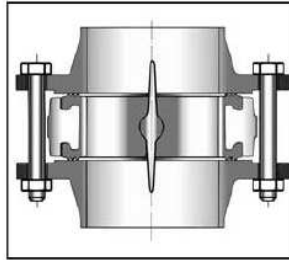

Complete opened disc valves
when screw tightening

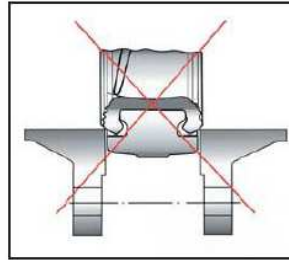

- Tighten the bolts in cross.
- The disc must move easily inside the pipe.
- Valves must be opened during cleaning operation.
- Tests must be done with a cleaned pipe.
- Tests must be done with opened valve. Test pressure must not be higher than the valve specification according to ISO 5208.
- Then open slowly the valve.
- **Do not mount butterfly valves with stainless steel pressed collars and turning flanges without strias.**
- **And not on flat face flanges without strias (example : painted cast iron fittings)**

MAINTENANCE :

- We recommend to operate fully the valve 1 to 2 times per year.
- During maintenance operation, ensure that the pipe isn't under pressure, that there's no fluid in the pipe and that the valve is isolated. If there's a fluid in the pipe , evacuate it. Ensure that there are no risks due to the temperature or the fluid (like acids). If the fluid is corrosive , inert the installation before maintenance operation.