

V46

V46 121.402 class600 DN1/2" – DN2"
Globe valve with stainless steel bellow socket welding SW



Size : DN 15 to 50 (NPS 1/2" to 2")
Ends : Female - Female BSP or NPT, Socket Welding
Min Temperature : - 29°C
Max Temperature : + 425°C
Max Pressure : 100 Bars (Class 600)
Specifications : Rising stem non rotating
Bolted bonnet and gland pack
Standard port

Materials : Carbon steel

V46

V46 121.402 class600 DN1/2" – DN2" Globe valve with stainless steel bellow socket welding SW

SPECIFICATIONS :

- Respect the flow direction (indicated by the arrow)
- Standard port
- Rising stem non rotating
- Bolted bonnet and gland pack
- Forged Carbon steel
- ½ stellite (Trim 8)
- Stainless steel bellow
- Class 600

USE :

- Petroleum industry, steam, high pressure
- Min and max Temperature Ts : - 29°C to + 425°C
- Max Pressure Ps : 100 bars (see graph)

PRESSURE / TEMPERATURE GRAPH :

Pressure

(Bar)

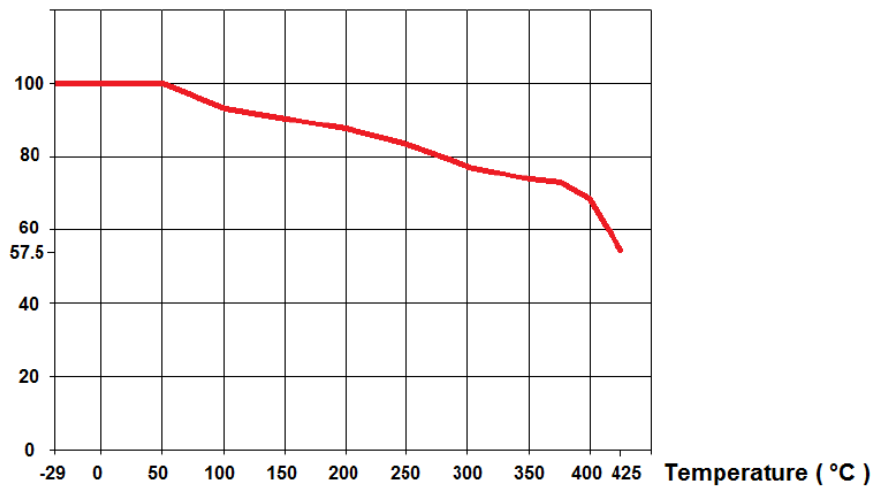

Pressure (bar)	100	100	100	92.8	90.5	87.6	83.4	77.5	73.9	72.9	69	57.5
Temperature (°C)	-29	38	50	100	150	200	250	300	350	375	400	425

FLOW COEFFICIENT Kvs (M3 / h) :

DN	15	20	25	32	40	50
NPS	1/2"	3/4"	1"	1"1/4	1"1/2	2"
Kvs (m3/h)	1.3	3.3	5.9	9.5	12.4	21.6

RANGE :

- Forged A105N carbon steel globe valve with bellow and Socket Welding ends Ref. 402 DN 15 to DN 50 (NPS 1/2" to DN 2")
- Forged A105N carbon steel globe valve with bellow and NPT threaded ends Ref.403 DN 15 to DN 50 (NPS 1/2" to DN 2")
- Forged A105N carbon steel globe valve with bellow and BSP cylindrical threaded ends Ref.404 DN 15 to DN 50 (NPS 1/2" to DN 2")

MATERIALS:

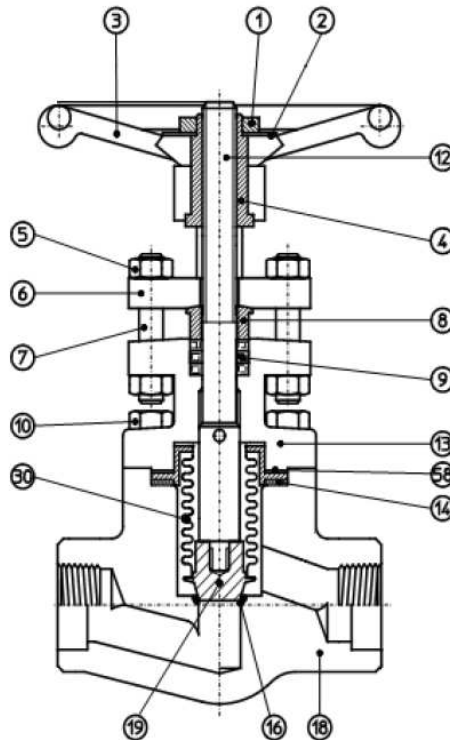

Item	Designation	Materials 402/403/404
1	Wheel nut	Carbon steel
2	Name plate	Aluminium
3	Handwheel	Carbon steel
4	Yoke nut	ASTM A582 type 416
5	Gland nut	ASTM A194 2H
6	Gland flange	ASTM A105
7	Gland stud	SS 410
8	Gland	ASTM A276 type 410
9	Packing	Graphite
10	Bolts	ASTM A193 B7
12	Stem	ASTM A276 type 410
13	Bonnet	ASTM A105N
14	Gasket	SS 316 + graphite spiral wound
16	Seat	Stellite GR.6
18	Body	ASTM A105N
19	Disc	ASTM A276 type 410
30	Bellow	ASTM A479 type 321
58	Gasket	Reinforced graphite

V46

V46 121.402 class600 DN1/2" – DN2"
Globe valve with stainless steel bellow socket welding SW

SIZE (in mm) :

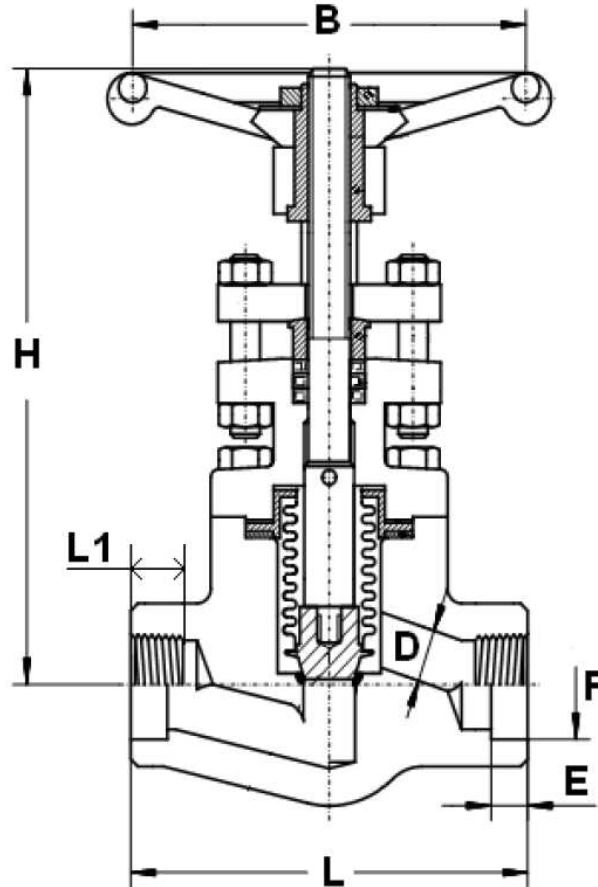

Ref.	DN (mm)	15	20	25	32	40	50
	NPS (")	1/2"	3/4"	1"	1"1/4	1"1/2	2"
402	Ø D	9	13	17.5	22.5	29.5	35
	L	80	90	110	127	155	170
403/404	H (open)	136	144	167	194	220	230
	Ø B	90	90	110	130	130	180
403/404	L1	15	18	19	20	21	21
402	E (SW)	12.7	14.5	16	17.5	19	22
	Ø F (SW)	21.72	27.05	33.78	42.54	48.64	61.11
402/403/404	Weight (Kg)	1.85	2.07	3.44	5	7.1	11

V46

V46 121.402 class600 DN1/2" – DN2" Globe valve with stainless steel bellow socket welding SW

STANDARDS :

- Fabrication according to **ISO 9001 : 2008**
- **DIRECTIVE 97/23/CE : CE N° 0036**
Risk category III module H
- Designing according to **ISO 15761** and **API 602 8th**
- Pressure Tests according to **API 598, table 6**
- Approval certificate Russian Federation **GOST-R**
- Valves approved by the main oil industries (certificates on request)
- **ATEX** Group II Category 2 G/2D Zone 1 & 21 Zone 2 & 22 (optional marking)
- Threaded female BSP cylindrical ends according to **ISO 7-1 Rp**
- Threaded female NPT ends according to **ANSI B1.20.1**

INSTALLATION INSTRUCTIONS

GENERAL GUIDELINES :

- Ensure that the valves to be used are appropriate for the conditions of the installation (type of fluid, pressure and temperature).
- Be sure to have enough valves to be able to isolate the sections of piping as well as the appropriate equipment for maintenance and repair.
- Ensure that the valves to be installed are of correct strength to be able to support the capacity of their usage.
- Installation of all circuits should ensure that their function can be automatically tested on a regular basis (at least two times a year).

INSTALLATION INSTRUCTIONS :

- Before installing the valves, clean and remove any objects from the pipes (in particular bits of sealing and metal) which could obstruct and block the valves.
- Ensure that both connecting pipes either side of the valve (upstream and downstream) are aligned (if they're not, the valves may not work correctly).
- Make sure that the two sections of the pipe (upstream and downstream) match, the valve unit will not absorb any gaps. Any distortions in the pipes may affect the tightness of the connection, the working of the valve and can even cause a rupture. To be sure, place the kit in position to ensure the assembling will work.
- During welding operation, for S.W. types half open the valve and do not exceed 350-400°C
- The theoretical lengths given by ISO/R7 for the tapping are typically longer than required, the length of the thread should be limited, and check that the end of the tube does not press right up to the head of the thread.
- Never use a vice to tighten the fixings of the valve.
- If sections of piping do not have their final support in place, they should be temporarily fixed. This is to avoid unnecessary strain on the valve.
- It may be necessary to screw the packing gland during using according to the type of use.
- Do not use a tool to shut the valve
- Fluids in the valve must not contain solid objects (it could damaged the seat).
- It's recommended to operate the valve (open and close) 1 to 2 times per year