

V30

V30 111 616.470 PN16 DN15-200
Globe valve flanged



Size : DN 15 to DN 200
Ends : PN16 Flanges R.F.
Min Temperature : - 10°C
Max Temperature : + 120°C
Max Pressure : 16 Bars
Specifications : Rising rotating stem and handwheel
Bolted bonnet and gland pack
SS seat

Materials : Cast iron body

V30

V30 111 616.470 PN16 DN15-200 Globe valve flanged

SPECIFICATIONS :

- Respect the flow direction indicated by the arrow
- Rising rotating stem and handwheel
- Bolted bonnet and gland pack
- Stainless steel seat
- PN16 Flanges R.F.
- Painting RAL 7011 grey color, 90 µm thickness

USE :

- For common fluids
- Min and max Temperature Ts : - 10°C to + 120°C
- Max Pressure Ps : 16 bars
- Keep greased the stem
- **Do not use for steam**
- Tighten the gland packing during the setting

RANGE :

- Cast iron body PN16 flanged R.F. Ref. 470 from DN 15 to DN 200

FLOW COEFFICIENT Kvs (M3 / h) :

DN	15	20	25	32	40	50	65	80	100	125	150	200
Kvs (m3/h)	5.9	7.4	13	18	30	41	79	115	181	225	364	690

NUMBER OF CYCLES TO CLOSE OR OPEN THE VALVE :

DN	15	20	25	32	40	50	65	80	100	125	150	200
Nb of cycles	5	7	9	7	10	9	11	8	9	12	13	15

V30

V30 111 616.470 PN16 DN15-200 Globe valve flanged

MATERIALS :

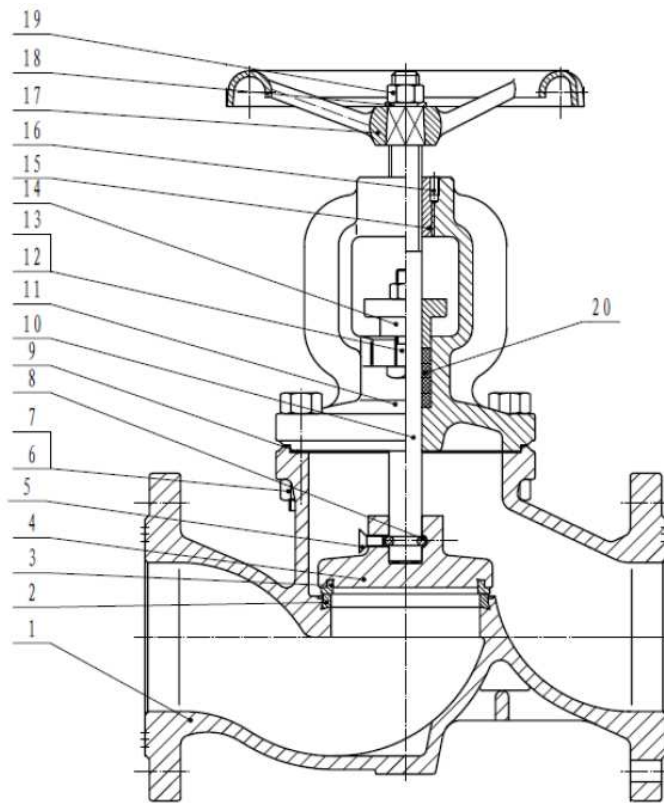

Item	Designation	Materials
1	Body	Cast iron EN GJL-250
2	Body seat	SS 420
3	Disc seat ring	SS 420
4	Disc	Cast iron EN GJL-250
5	Screw	RSt37-2 (1.0038)
6	Nut	RSt37-2 (1.0038)
7	Bolt	RSt37-2 (1.0038)
8	Ball	100Cr6
9	Bonnet gasket	Graphite
10	Stem	SS 420
11	Bonnet	Cast iron EN GJL-250
12	Bolt	RSt37-2 (1.0038)
13	Nut	RSt37-2 (1.0038)
14	Gland follower	Ductile iron EN GJS-500-7
15	Stem nut	Brass
16	Screw	RSt37-2 (1.0038)
17	Handwheel	Cast iron EN GJL-250
18	Washer	RSt37-2 (1.0038)
19	Handwheel nut	RSt37-2 (1.0038)
20	Packing	Graphite

V30

V30 111 616.470 PN16 DN15-200 Globe valve flanged

SIZE (in mm) :

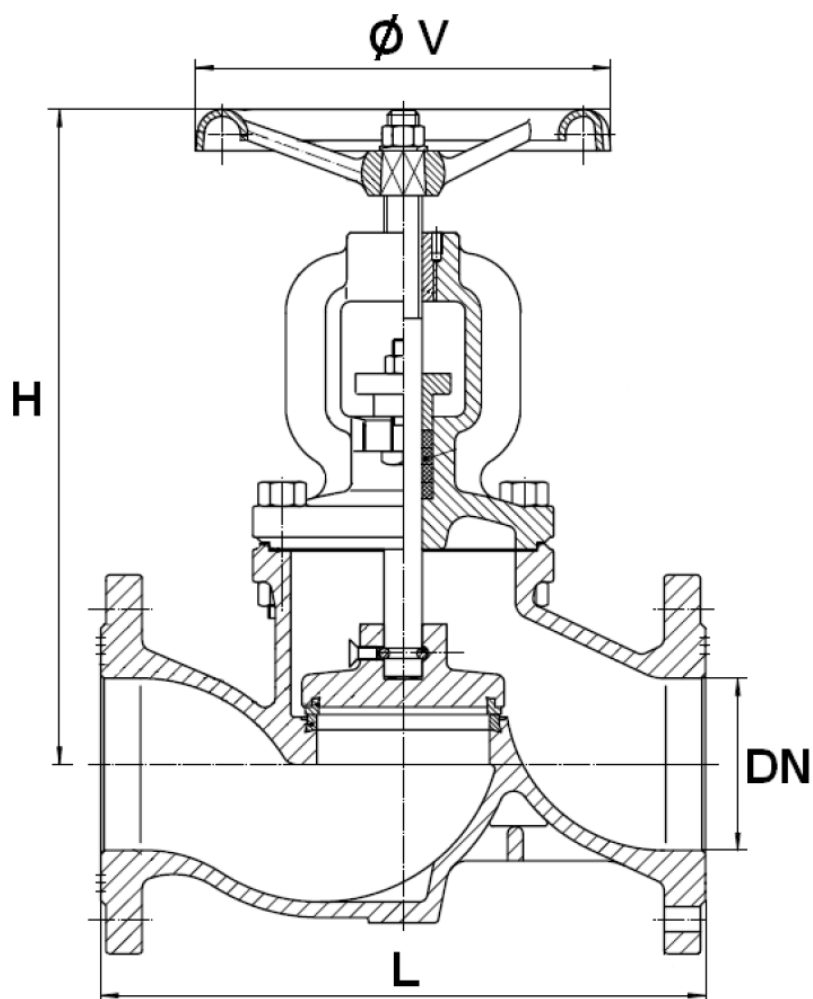

Ref.	DN	15	20	25	32	40	50	65	80	100	125	150	200
470	L	130	150	160	180	200	230	290	310	350	400	480	600
	H (closed)	161.5	169	187	223	233.5	261.5	293	341	381	419	485	569
	H (opened)	183	191	216	255	277	304	335	380	426	480	555	660
	Ø V	100	100	120	120	140	140	200	200	240	280	315	360
	Weight (Kg)	3.3	4	5.5	8.5	10.75	14.57	19.3	26.7	35.4	59	78	136

V30

V30 111 616.470 PN16 DN15-200 Globe valve flanged

FLANGES SIZE (in mm) :

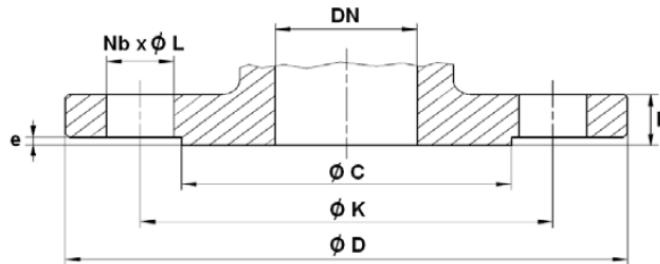

Ref.	DN	15	20	25	32	40	50	65	80	100	125	150	200
470	Ø C	46	56	65	76	84	99	118	132	156	184	211	266
	Ø D	95	105	115	140	150	165	185	200	220	250	285	340
	Ø K	65	75	85	100	110	125	145	160	180	210	240	295
	Nb x Ø L	4 x 14	4 x 14	4 x 14	4 x 19	4 x 19	4 x 19	4 x 19	8 x 19	8 x 19	8 x 19	8 x 23	12 x 23
	b	14	16	16	18	18	20	20	22	24	26	26	30
	e	2	2	3	3	3	3	3	3	3	3	3	3

STANDARDS :

- Fabrication according to ISO 9001 :2008
- DIRECTIVE 97/23/CE : Concerned by article 3, § 3
- Length according to EN 558 series 1 (DIN 3202 F1)
- PN16 Flanges R.F. according to EN 1092-2

V30

V30 111 616.470 PN16 DN15-200
Globe valve flanged

INSTALLATION INSTRUCTIONS

GENERAL GUIDELINES :

- Ensure that the valves to be used are appropriate for the conditions of the installation (type of fluid, pressure and temperature).
- Be sure to have enough valves to be able to isolate the sections of piping as well as the appropriate equipment for maintenance and repair.
- Ensure that the valves to be installed are of correct strength to be able to support the capacity of their usage.
- **Installation of all circuits should ensure that their function can be automatically tested on a regular basis (at least two times a year).**

INSTALLATION INSTRUCTIONS :

- **Before installing the valves, clean and remove any objects from the pipes** (in particular bits of sealing and metal) which could obstruct and block the valves.
- **Ensure that both connecting pipes either side of the valve (upstream and downstream) are aligned (if they're not, the valves may not work correctly).**
- **Make sure that the two sections of the pipe (upstream and downstream) match, the valve unit will not absorb any gaps. Any distortions in the pipes may affect the tightness of the connection, the working of the valve and can even cause a rupture. To be sure, place the kit in position to ensure the assembling will work.**
- **If sections of piping do not have their final support in place, they should be temporarily fixed. This is to avoid unnecessary strain on the valve.**
- Tighten the bolts in cross.
- It's recommended to operate the valve (open and close) 1 to 2 times per year
- Tighten the gland packing at the first start of the installation (with a moderate torque) so that there's no leakage and the handwheel is easy to operate.
- Do not use tools to operate the handwheel
- Respect the flow direction indicated by the arrow