

# K85

K85 131 5500.799 PN500 DN1/4"-2"  
Ball valve threaded BSP



**Size :** DN 1/4" to 2"  
**Ends :** Threaded Female BSP  
**Min Temperature :** -10°C  
**Max Temperature :** + 100°C  
**Max Pressure :** 315 – 500 Bars  
**Specifications :** Reduced bore  
High pressure  
Hydraulic type

**Materials :** Galvanized steel

# K85

**K85 131 5500.799 PN500 DN1/4"-2"  
Ball valve threaded BSP**

**SPECIFICATIONS :**

- Reduced bore
- Galvanized steel
- High pressure
- Hydraulic type

**USE :**

- For all common fluids
- Min and max Temperature Ts : -10°C to + 100°C
- Max Pressure Ps : 500 bars from DN1/4" to 1/2" and 315 over ( see graph )

**PRESSURE / TEMPERATURE GRAPH ( STEAM EXCLUDED ) :**

**PRESSURE**

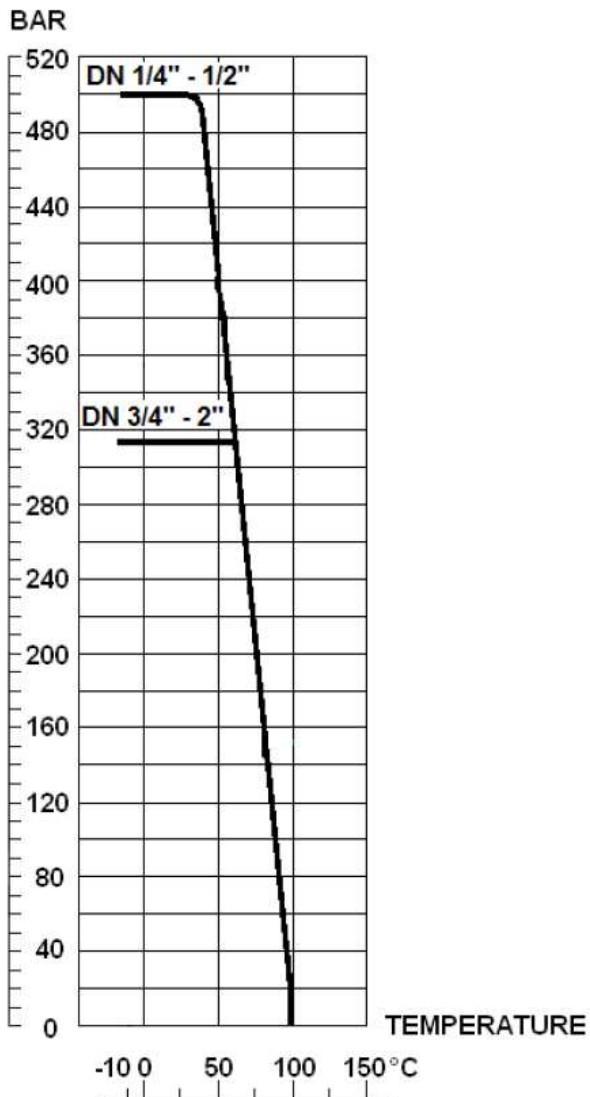

# K85

## K85 131 5500.799 PN500 DN1/4"-2" Ball valve threaded BSP

FLOW COEFFICIENT Kvs ( M3 / h ) :

DN	1/4"	3/8"	1/2"	3/4"	1"	1"1/4	1"1/2	2"
Kvs ( m3/h )	4.2	6	30.2	53.7	90.6	90.6	245.2	364.5

RANGE :

- High pressure ball valve with galvanized steel body **Ref. 799** DN 1/4" to 2"

ENDS :

- Threaded cylindrical female BSP

# K85

## K85 131 5500.799 PN500 DN1/4"-2" Ball valve threaded BSP

MATERIALS DN1/4" - 1"1/4" :

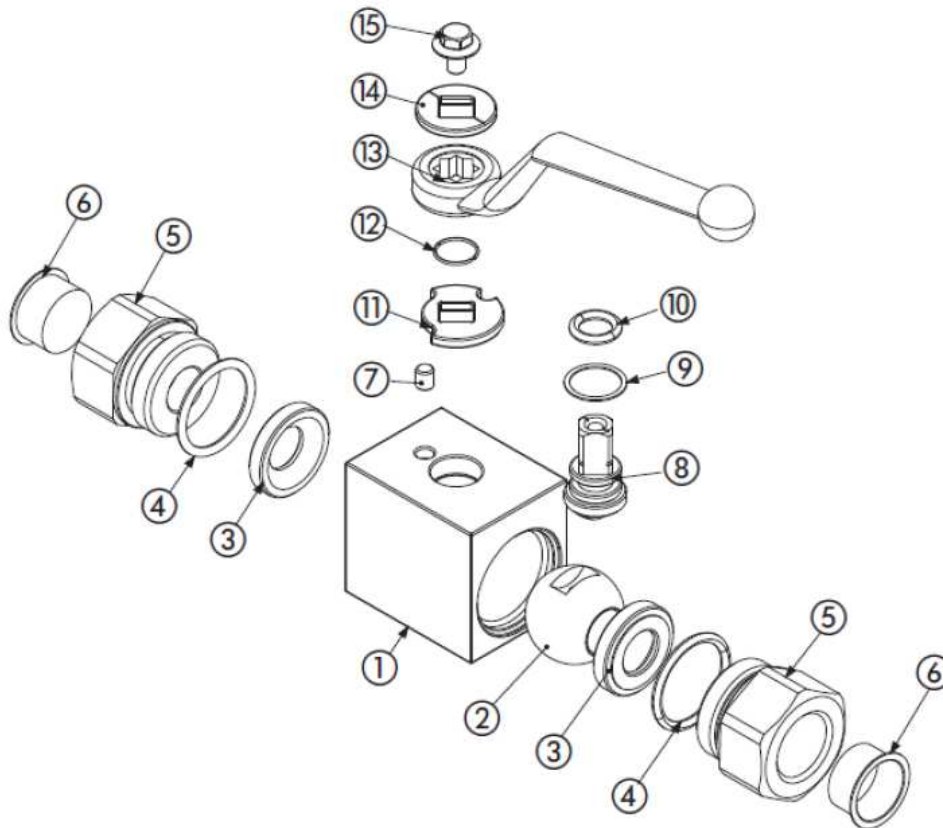

Item	Designation	Materials DN 1/4" - 1"1/4
1	Body	Galvanized 1.0737 steel
2	Ball	Chromed 1.0737 steel
3	Seat	POM
4	O-ring	NBR
5	Ends	Galvanized 1.0737 steel
6	Caps	PVC
7	Spine	Steel 1.0737
8	Stem	Steel 1.0737
9	Stem seal	POM
10	O-ring	NBR
11	Washer	Steel 1.0116
12	Seeger	Steel 1.4301
13	Handle	Aluminium
14	Handle washer	Steel 1.0116
15	Handle screw	Steel DIN 6921 8.8

# K85

## K85 131 5500.799 PN500 DN1/4"-2" Ball valve threaded BSP

MATERIALS DN1"1/2 - 2":

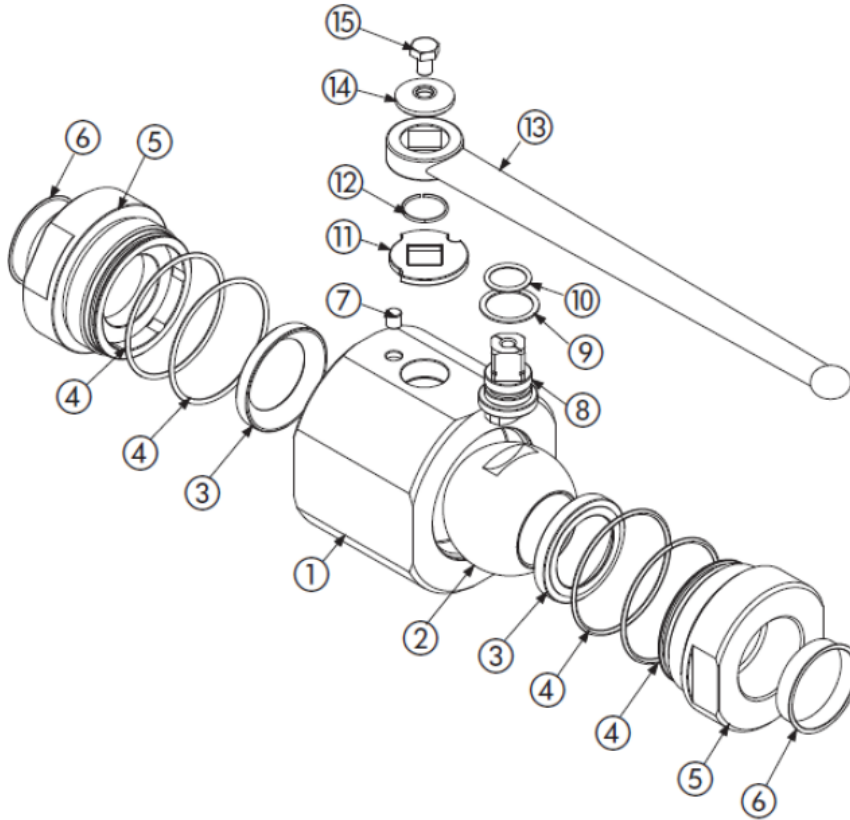

Item	Designation	Materials DN 1"1/2 - 2"
1	Body	Galvanized 1.0570 steel
2	Ball	Chromed 1.0737 steel
3	Seat	POM
4	O ring	NBR
5	Ends	Galvanized 1.0570 steel
6	Caps	PVC
7	Spine	Steel 1.0737
8	Stem	Steel 1.0737
9	Stem gasket	POM
10	O ring	NBR
11	Washer	Steel 1.0116
12	Seeger	Steel 1.4301
13	Handle	Steel 1.0116
14	Washer	Steel 1.0737
15	Handle screw	Steel ISO 4017 8.8

# K85

## K85 131 5500.799 PN500 DN1/4"-2" Ball valve threaded BSP

SIZE DN1/4" - 1"1/4 (in mm) :

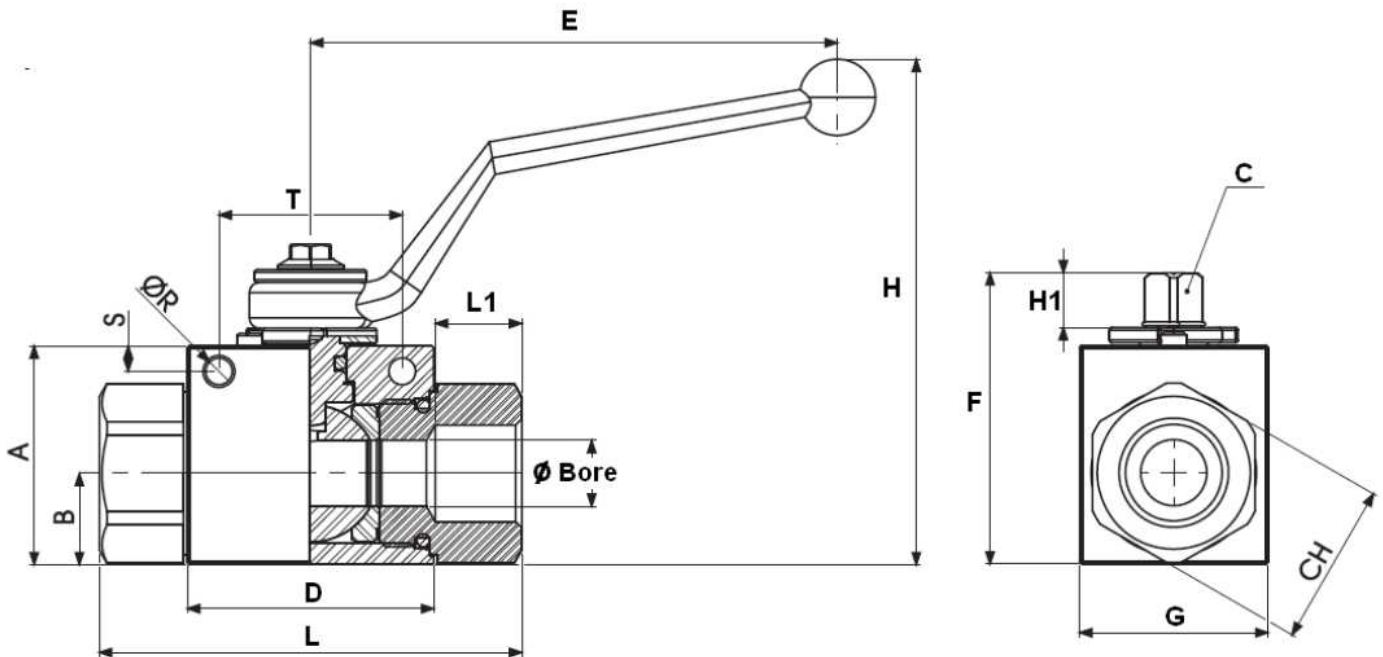

Stem size :

Ref.	DN	1/4"	3/8"	1/2"	3/4"	1"	1"1/4"
799	Ø Bore	6	10	13	20	25	25
	L	71	73	83	95	112	120
	L1	15.5	15.5	17	21	24	24
	E	110	110	110	180	180	180
	H	91.5	96.5	99.5	106.5	116.5	116.5
	H1	11	11	11	14	14	14
	A	35	40	43	55	65	65
	B	14.5	17.4	18	23.4	29.5	29.5
	C	9	9	9	14	14	14
	CH	24	30	32	41	50	55
	D	42.4	44.4	48.4	62.5	66.5	66.5
	F	49	54.25	57	73.5	83.5	83.5
	G	30	35	37	45	55	55
	Ø R	5.25	5.25	5.25	6.25	6.25	6.25
	S	4.5	4.5	5	6	6	6
T	34	34	36	50	50	50	
Weight ( Kg )		0.49	0.644	0.757	1.438	2.223	2.273

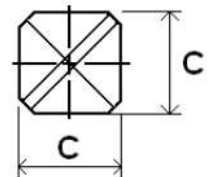
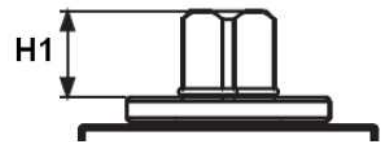

# K85

## K85 131 5500.799 PN500 DN1/4"-2" Ball valve threaded BSP

SIZE DN1"1/2 - 2" ( in mm ) :

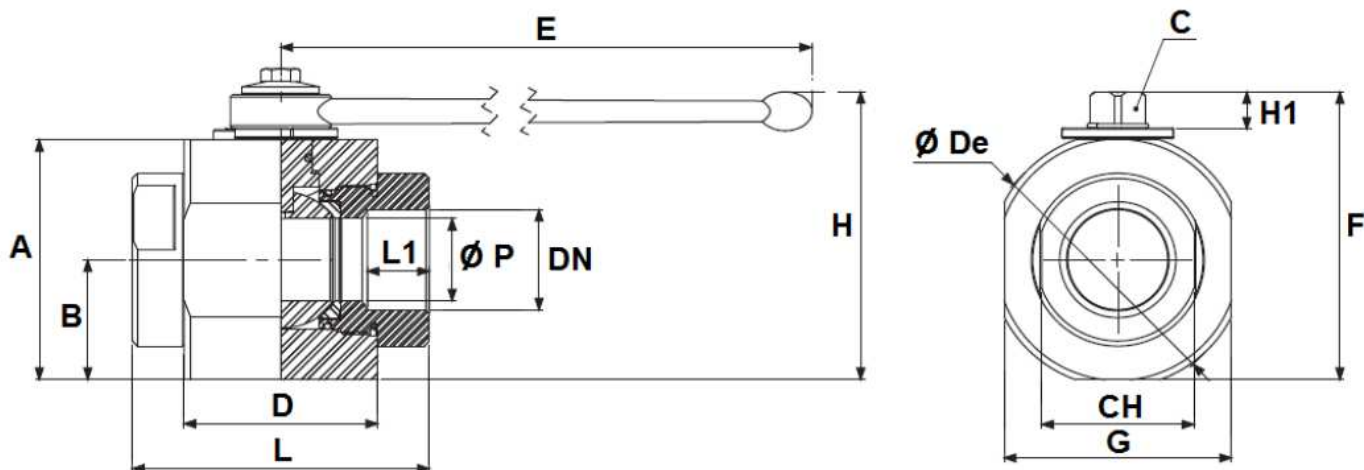

Stem size :

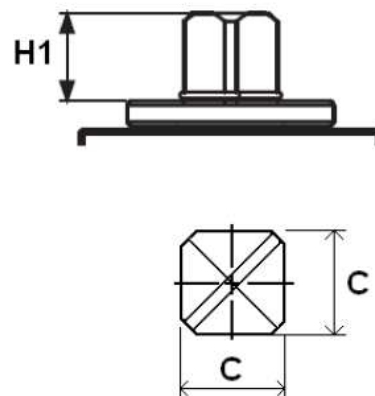

Ref.	DN	1"1/2	2"
799	Ø P	40	50
	L	131	140
	L1	25	27
	E	300	300
	H	134.5	141.5
	H1	13.5	13.5
	A	107	114
	B	53.5	57
	C	17	17
	CH	75	85
	D	85	98
	F	125.5	132.5
	G	102	118
	Ø De	113	123
Weight (in Kg)		7.39	9.05

# K85

## K85 131 5500.799 PN500 DN1/4“-2“ Ball valve threaded BSP

TORQUE VALUES ( in Nm without safety coefficient ) :

DN	1/4"	3/8"	1/2"	3/4"	1"	1"1/4	1"1/2	2"
Torque ( Nm )	16	18	25	45	72	90	160	250

STANDARDS :

- Fabrication according to ISO 9001 : 2008
- DIRECTIVE 97/23/CE : Products excluded from directive ( Article 3, § 3 ) up to DN1"1/4  
Risk category II Module A1, **CE N°0948** from DN1"1/2 to 2"
- Tests according to API 598
- Threaded cylindrical BSP ends according to ISO 228-1
- On request, ATEX according to article 8 1bII from directive 94/9/CE ( N°TUV IT 07 ATEX 002 AR )

### INSTALLATION AND MAINTENANCE

#### BEFORE INSTALLATION :

Pipe-line must be cleaned and free from residual of weldings, rubbish, shaving and every kind of extraneous materials.  
Pipe-line must be perfectly aligned and their support properly dimensioned so that there's no external constraint.

Please use the right product according to the services conditions to seal the valve.  
Use the right bolt tightening so that the ends won't be damaged.

#### CLEANING AND TESTS

Keep closed the valves during the cleaning operation so that there's no impurities between the ball and the body.

Tests under pressure must be done with a cleaned pipe-line.

Open partially the valve for tests. Pressure test do not exceed the valve specifications according to API 598.

#### MAINTENANCE

It's recommended to operate the valve twice ( open and close ) 1 to 2 times per year.

When intervention on the valve, be sure there's no pressure in the pipe-line, there's no fluid in it, and that it is isolated.  
The temperature must be low enough to operate without risks.  
If there's a corrosive fluid, inert installation before intervention.