

V30

V30 111.443 class150 DN2" – DN12"
Globe valve flange ANSI



PED 2014/68/UE



Certificate 3.1

Size : DN 50 to DN 300 (NPS 2" to 12")
Ends : Flanges R.F. CLASS 150 (PN20)
Min Temperature : - 29°C
Max Temperature : + 425°C
Max Pressure : 20 Bars
Specifications : Rising rotating stem
Bolted bonnet and gland pack
Full bore

Materials : Carbon steel ASTM A216 WCB



V30

V30 111.443 class150 DN2" – DN12" Globe valve flange ANSI

SPECIFICATIONS :

- Full bore
- Rising rotating stem
- Rising handwheel
- Respect the flow direction indicated by the arrow
- Flanges R.F. Class 150 (PN20)
- Carbon steel
- Bolted bonnet and gland pack
- ½ stellite (Trim 8 , seat with stellite)
- Grey painting RAL 7001 color, 60 µm thickness

USE :

- Water distribution, gas oil, steam, petrochemical, petroleum industry, gas
- Min and max Temperature Ts : - 29°C to + 425°C
- Max Pressure Ps : 20 bars
- Tighten the gland packing in service

FLOW COEFFICIENT Kvs :

DN (mm)	50	80	100	150	200	250	300
NPS (")	2"	3"	4"	6"	8"	10"	12"
Kvs	39	99.8	156	351	624	975	1404

PRESSURE / TEMPERATURE RELATION :

(According to AMSE B16-34 for A216 WCB)

Pressure (Bar)	19.6	19.6	17.9	15.8	13.8	11.7	9.6	8.6	7.6	6.5	5.5
Temperature (°C)	-29	38	93	149	204	260	316	343	371	399	425

PRESSURE / TEMPERATURE GRAPH :

Pressure

(Bar)

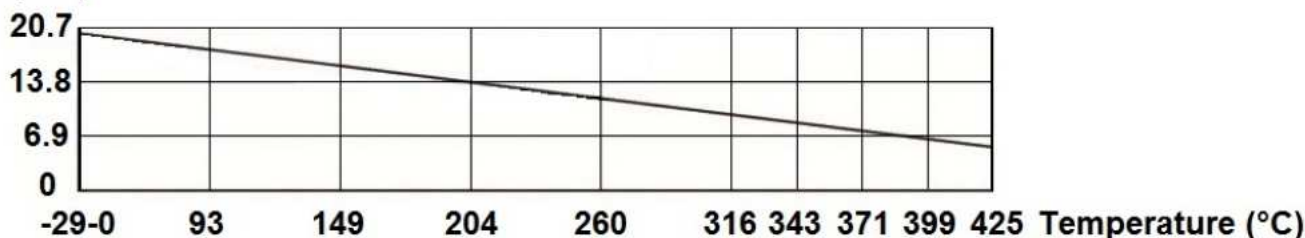

RANGE :

- Carbon steel globe valve R.F. flanged Class 150 (PN20) Ref. 443 From DN 50 to DN 300 (NPS 2" to 12")

MATERIALS DN50-200 (NPS 2"-8"):

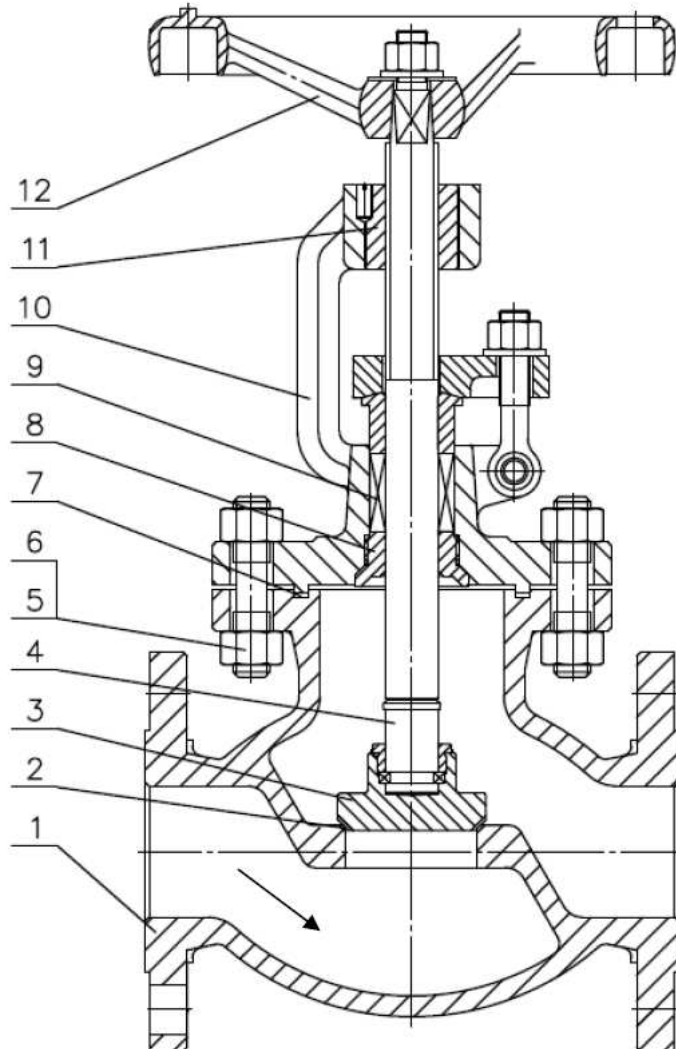

(* : included in gaskets kit)

Item	Designation	Materials
1	Body	ASTM A216 WCB
2	Seat	Deposited stellite Gr.6
3	Disc	ASTM A105 + 13Cr
4	Stem	ASTM A182 F6a
5	Sutd bolt	ASTM A193 Gr B7
6	Nut	ASTM A194 Gr 2H
7*	Bonnet gasket	AISI 304 + graphite
8*	Back seat bushing	ASTM A276-420
9*	Packing	Flexible graphite
10	Bonnet	ASTM A216 WCB
11	Stem nut	Aluminium + Bronze
12	Handwheel	Cast iron

V30

V30 111.443 class150 DN2" – DN12" Globe valve flange ANSI

MATERIALS DN250-300 (NPS 10"-12"):

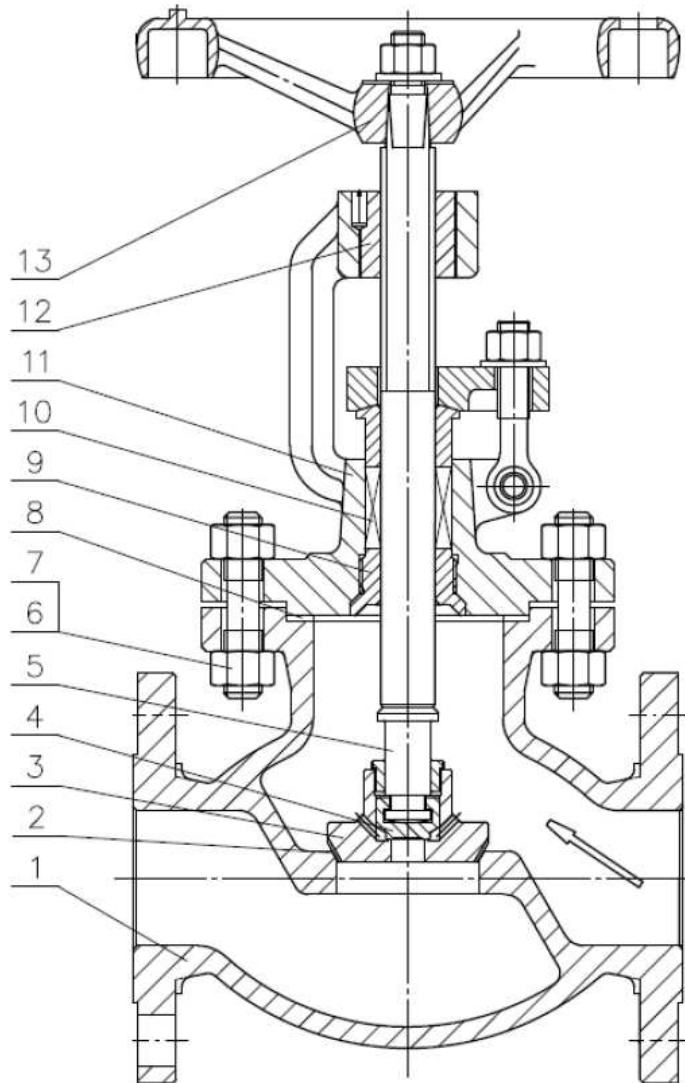

(* : included in gaskets kit)

Item	Designation	Materials
1	Body	ASTM A216 WCB
2	Seat	Deposited stellite Gr.6
3	Disc	ASTM A105 + 13Cr
4	Secondary disc	ASTM A276-420
5	Stem	ASTM A182 F6a
6	Stud bolt	ASTM A193 Gr B7
7	Nut	ASTM A194 Gr 2H
8*	Bonnet gasket	AISI 304 + graphite
9*	Back seat bushing	ASTM A276-410
10*	Packing	Flexible graphite
11	Bonnet	ASTM A216 WCB
12	Stem nut	Aluminium + Bronze
13	Handwheel	Cast iron

V30

V30 111.443 class150 DN2" – DN12" Globe valve flange ANSI

SIZE DN50-200 (NPS 2"-8") (in mm) :

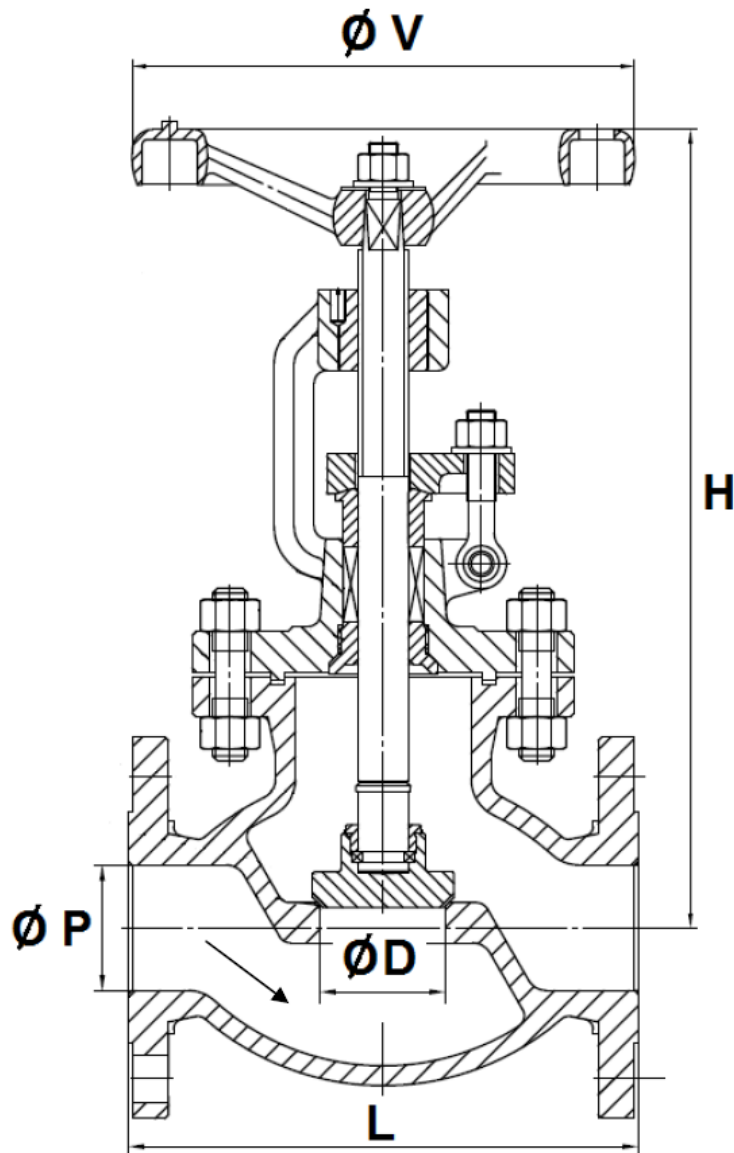

Ref.	DN (mm)	50	80	100	150	200
	NPS (")	2"	3"	4"	6"	8"
443	Ø P	51	76	102	152	203
	Ø D	51	76	102	152	200
	L	203	241	292	406	495
	H (opened)	327	390	438	555	666
	H (closed)	310	365	404	504	598
	Ø V	200	240	280	350	400
	Weight (Kg)	17	34	49	95	160

V30

V30 111.443 class150 DN2" – DN12"
Globe valve flange ANSI

SIZE DN250-300 (NPS 10"-12") (in mm) :

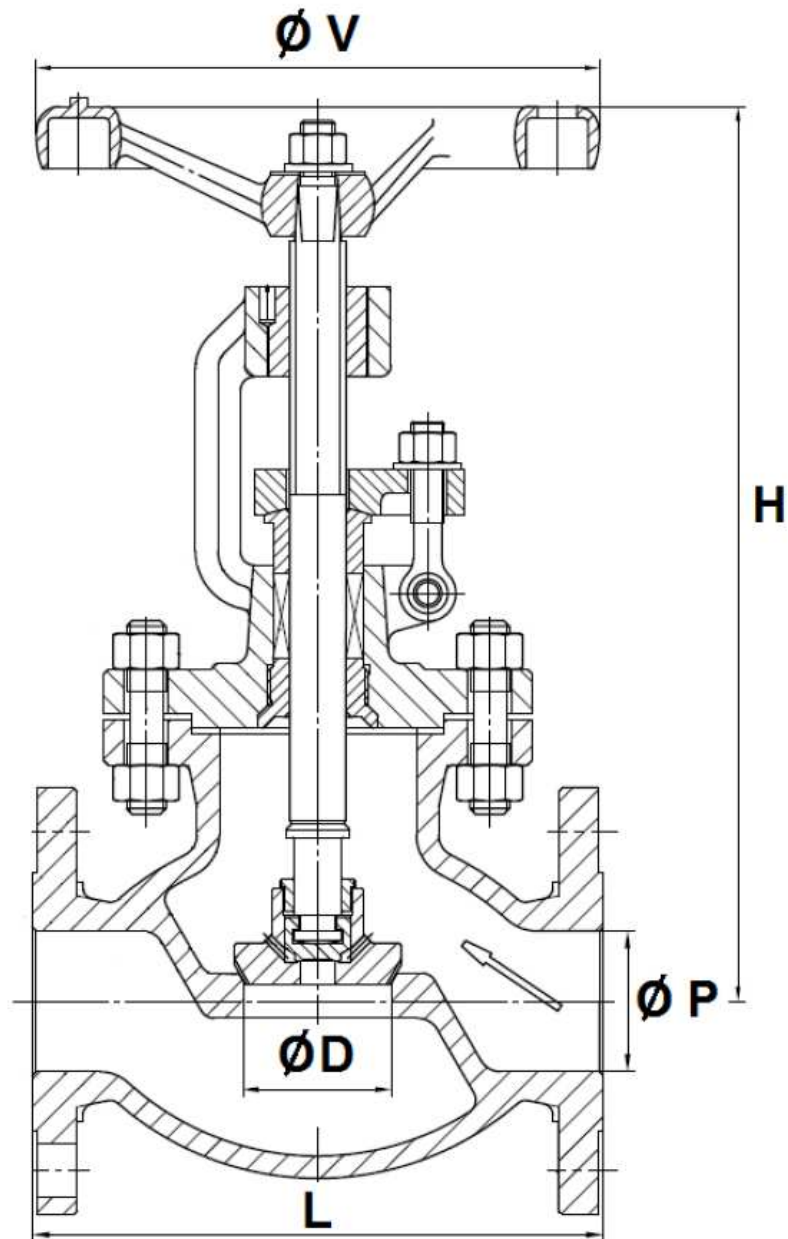

Ref.	DN (mm)	250	300
	NPS (")	10"	12"
443	Ø P	254	305
	Ø D	245	290
	L	622	698
	H (opened)	925	1042
	H (closed)	840	940
	Ø V	500	600
	Weight (Kg)	280	380

V30

V30 111.443 class150 DN2" – DN12"
Globe valve flange ANSI

FLANGES SIZE (in mm) :

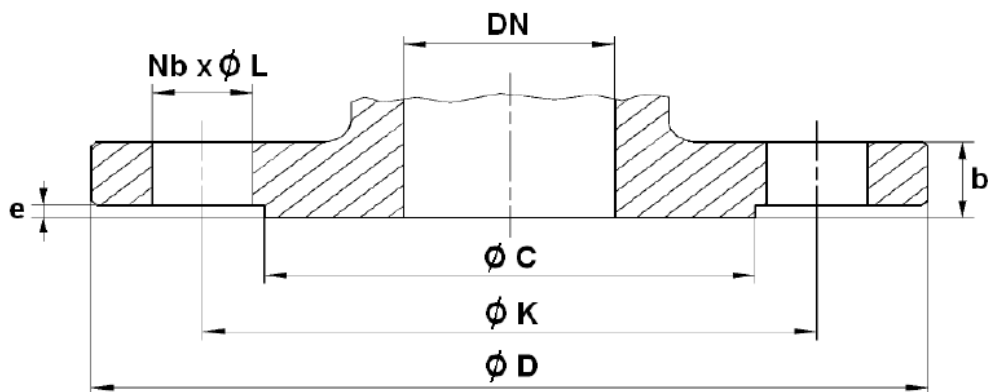

DN (mm)	50	80	100	150	200	250	300
NPS (")	2"	3"	4"	6"	8"	10"	12"
Ø C	92.1	127	157.2	215.9	269.9	323.8	381
Ø D	150	190	230	280	345	405	485
Ø K	120.7	152.4	190.5	241.3	298.5	362	431.8
Nb x Ø L	4 x 19	4 x 19	8 x 19	8 x 22	8 x 22	12 x 26	12 x 26
b	16.3	19.5	24.3	25.9	29	30.6	32.2
e	2	2	2	2	2	2	2

V30

V30 111.443 class150 DN2" – DN12" Globe valve flange ANSI

TORQUE VALUE (in Nm without safety coefficient) :

DN	50	80	100	150	200	250	300
NPS (")	2"	3"	4"	6"	8"	10"	12"
Torque (Nm)	19	45	67	129	245	385	601

NUMBER OF CYCLES TO CLOSE OR OPEN THE VALVE :

DN	50	80	100	150	200	250	300
NPS (")	2"	3"	4"	6"	8"	10"	12"
Number of cycles	5	5	7	9	11	11	13

STANDARDS :

- Fabrication according to ISO 9001 : 2008 and ISO 14001 : 2004
- DIRECTIVE 2014/68/EU : CE N° 0036
Risk category III Module H
- Certificate 3.1 on request
- Designing according to BS 1873
- Pressure Tests according to API 598, table 6
- Length according to ASME B16.10, table 1 A15 series and EN 558 series 10 (EN558 series 7 for DN150 6")
- Flanges R.F. according to ASME B16.05 Class 150
- ATEX Group II Category 2 G/2D Zone 1 & 21 Zone 2 & 22 (optional marking)
- Materials according to NACE MR 01-75 **on request**

INSTALLATION INSTRUCTIONS

GENERAL GUIDELINES :

- Ensure that the valves to be used are appropriate for the conditions of the installation (type of fluid, pressure and temperature).
- Be sure to have enough valves to be able to isolate the sections of piping as well as the appropriate equipment for maintenance and repair.
- Ensure that the valves to be installed are of correct strength to be able to support the capacity of their usage.
- **Installation of all circuits should ensure that their function can be automatically tested on a regular basis (at least two times a year).**

INSTALLATION INSTRUCTIONS :

- **Before installing the valves, clean and remove any objects from the pipes** (in particular bits of sealing and metal) which could obstruct and block the valves.
- **Ensure that both connecting pipes either side of the valve (upstream and downstream) are aligned (if they're not, the valves may not work correctly).**
- **Make sure that the two sections of the pipe (upstream and downstream) match, the valve unit will not absorb any gaps. Any distortions in the pipes may affect the tightness of the connection, the working of the valve and can even cause a rupture. To be sure, place the kit in position to ensure the assembling will work.**
- **If sections of piping do not have their final support in place, they should be temporarily fixed. This is to avoid unnecessary strain on the valve.**
- Tighten the bolts in cross.
- It's recommended to operate the valve (open and close) 1 to 2 times per year
- Tighten the gland packing at the first start of the installation (with a moderate torque) so that there's no leakage and the handwheel is easy to operate.
- Do not use tools to operate the handwheel
- Respect the flow direction indicated by the arrow