

# V30

V30 111.444 class300 DN2" – DN12"  
Globe valve flange ANSI



PED 2014/68/UE



Certificate 3.1

**Size :** DN 50 to DN 300 ( NPS 2" to 12" )  
**Ends :** Flanges R.F. CLASS 300 (PN50)  
**Min Temperature :** - 29°C  
**Max Temperature :** + 425°C  
**Max Pressure :** 50 Bars  
**Specifications :** Rising rotating stem  
Bolted bonnet and gland pack  
Full bore

**Materials :** Carbon steel ASTM A216 WCB



# V30

## V30 111.444 class300 DN2" – DN12" Globe valve flange ANSI

### SPECIFICATIONS :

- Full bore
- Rising rotating stem
- Rising handwheel
- Respect the flow direction indicated by the arrow
- Flanges R.F. Class 300 (PN50)
- Carbon steel
- Bolted bonnet and gland pack
- ½ stellite ( Trim 8 , seat with stellite )
- Grey painting RAL 7001 color, 60 µm thickness

### USE :

- Water distribution, gas oil, steam, petrochemical, petroleum industry, gas
- Min and max Temperature Ts : - 29°C to + 425°C
- Max Pressure Ps : 50 bars
- Tighten the gland packing in service

### FLOW COEFFICIENT Kvs :

DN ( mm )	50	80	100	150	200	250	300
NPS ( " )	2"	3"	4"	6"	8"	10"	12"
Kvs	60	94	162.8	366.3	651.1	1017.4	1456

### PRESSURE / TEMPERATURE RELATION :

( According to AMSE B16-34 for A216 WCB )

Pressure ( Bar )	51.1	51.1	46.2	45.1	43.8	41.3	37.9	36.9	36.9	34.8	28.2
Temperature ( °C )	-29	38	93	149	204	260	316	343	371	399	425

### PRESSURE / TEMPERATURE GRAPH :

Pressure (Bar)



RANGE : -29-0 93 149 204 260 316 343 371 399 425 Temperature (°C)

- Carbon steel globe valve R.F. flanged Class 300 (PN50) Ref. 444 From DN 50 to DN 300 ( NPS 2" to 12" )

# V30

## V30 111.444 class300 DN2" – DN12" Globe valve flange ANSI

MATERIALS DN50-150 ( NPS 2"-6"):

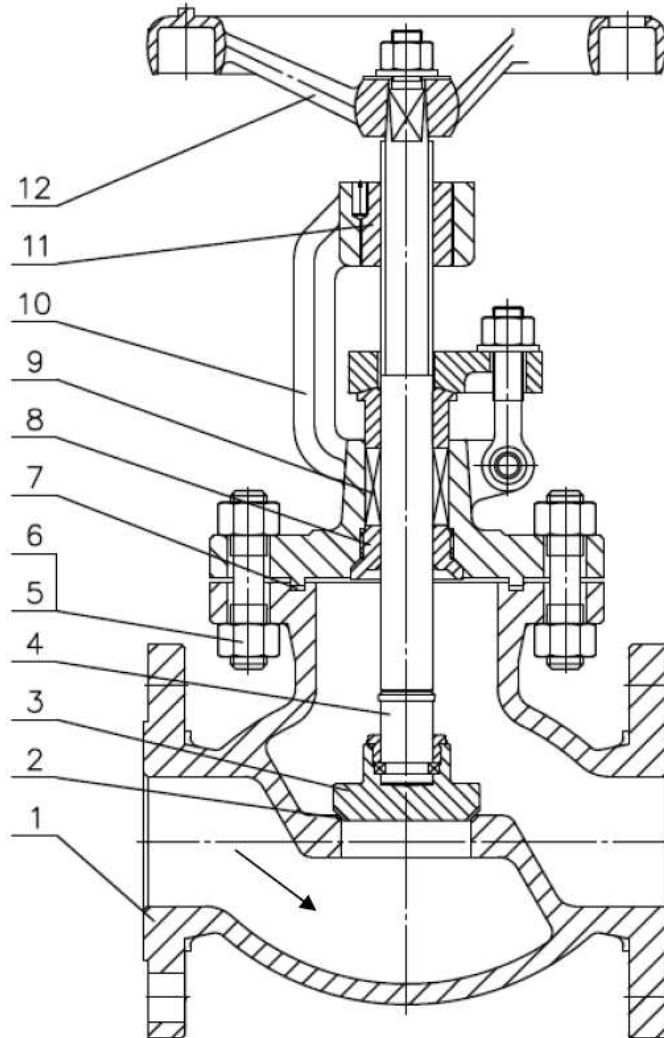

(\* : included in gaskets kit )

Item	Designation	Materials
1	Body	ASTM A216 WCB
2	Seat	Deposited stellite Gr.6
3	Disc	ASTM A105 + 13Cr
4	Stem	ASTM A182 F6a
5	Sutr bolt	ASTM A193 Gr B7
6	Nut	ASTM A194 Gr 2H
7*	Bonnet gasket	AISI 304 + graphite
8*	Back seat bushing	ASTM A276-420
9*	Packing	Flexible graphite
10	Bonnet	ASTM A216 WCB
11	Stem nut	Aluminium + Bronze
12	Handwheel	Cast iron

MATERIALS DN200-300 ( NPS 8"-12" ):

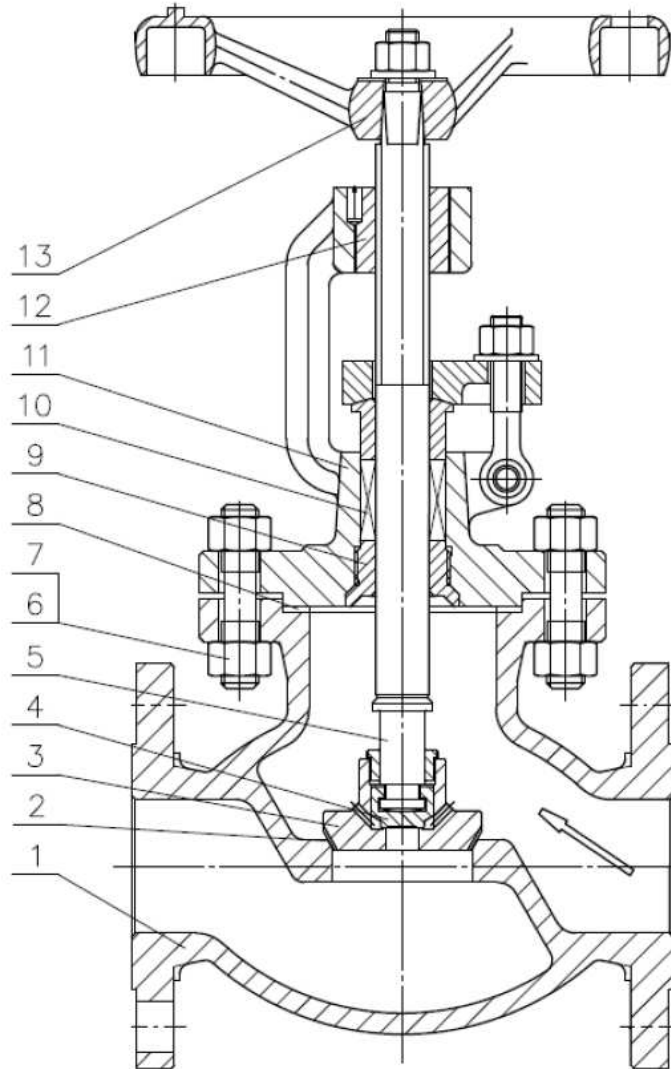

(\* : included in gaskets kit )

Item	Designation	Materials
1	Body	ASTM A216 WCB
2	Seat	Deposited stellite Gr.6
3	Disc	ASTM A105 + 13Cr
4	Secondary disc	ASTM A276-420
5	Stem	ASTM A182 F6a
6	Stud bolt	ASTM A193 Gr B7
7	Nut	ASTM A194 Gr 2H
8*	Bonnet gasket	AISI 304 + graphite
9*	Back seat bushing	ASTM A276-410
10*	Packing	Flexible graphite
11	Bonnet	ASTM A216 WCB
12	Stem nut	Aluminium + Bronze
13	Handwheel	Cast iron

# V30

V30 111.444 class300 DN2" – DN12"  
Globe valve flange ANSI

SIZE DN50-150 (NPS 2"-6") ( in mm ) :

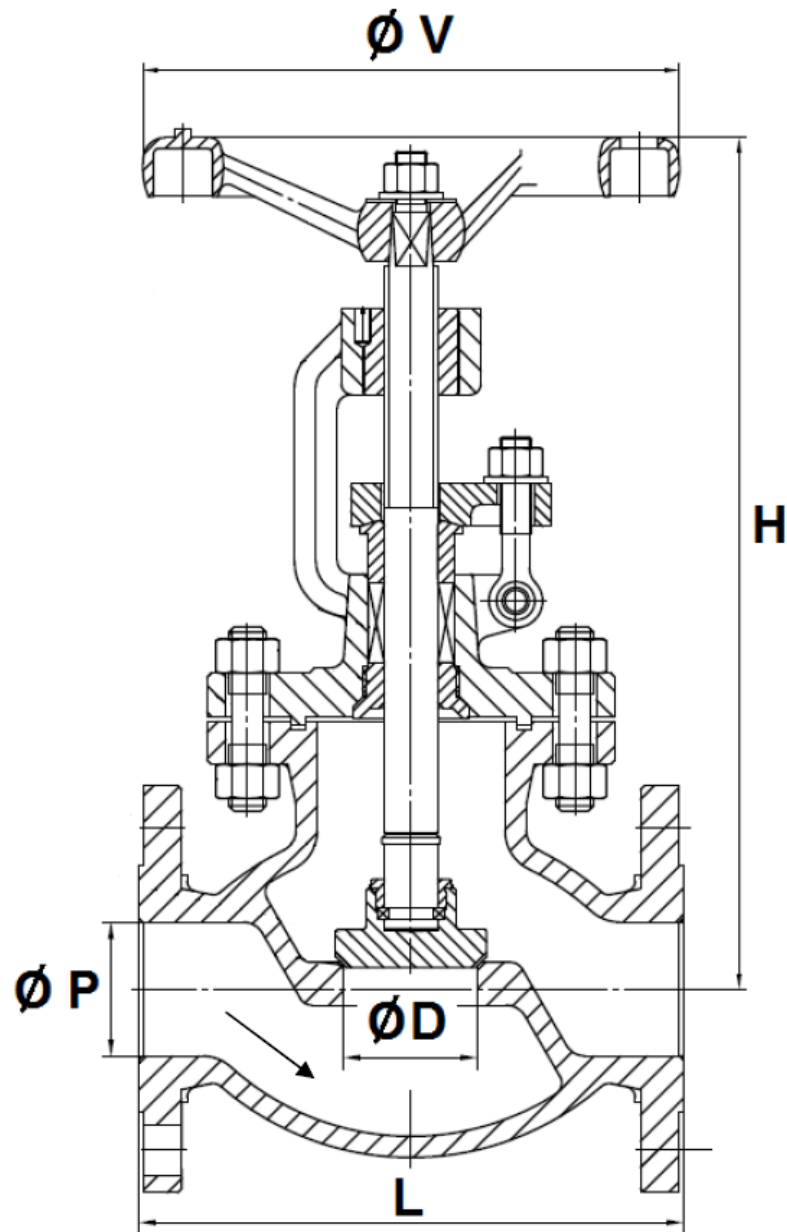

Ref.	DN ( mm )	50	80	100	150
	NPS ( " )	2"	3"	4"	6"
444	Ø P	51	76	102	152
	Ø D	51	76	102	152
	L	267	318	356	444
	H ( opened )	352	435	504	641
	H ( closed )	335	410	470	590
	Ø V	220	280	350	400
	Weight (Kg)	27	50	74	138

# V30

V30 111.444 class300 DN2" – DN12"  
Globe valve flange ANSI

SIZE DN200-300 (NPS 8"-12") ( in mm ) :

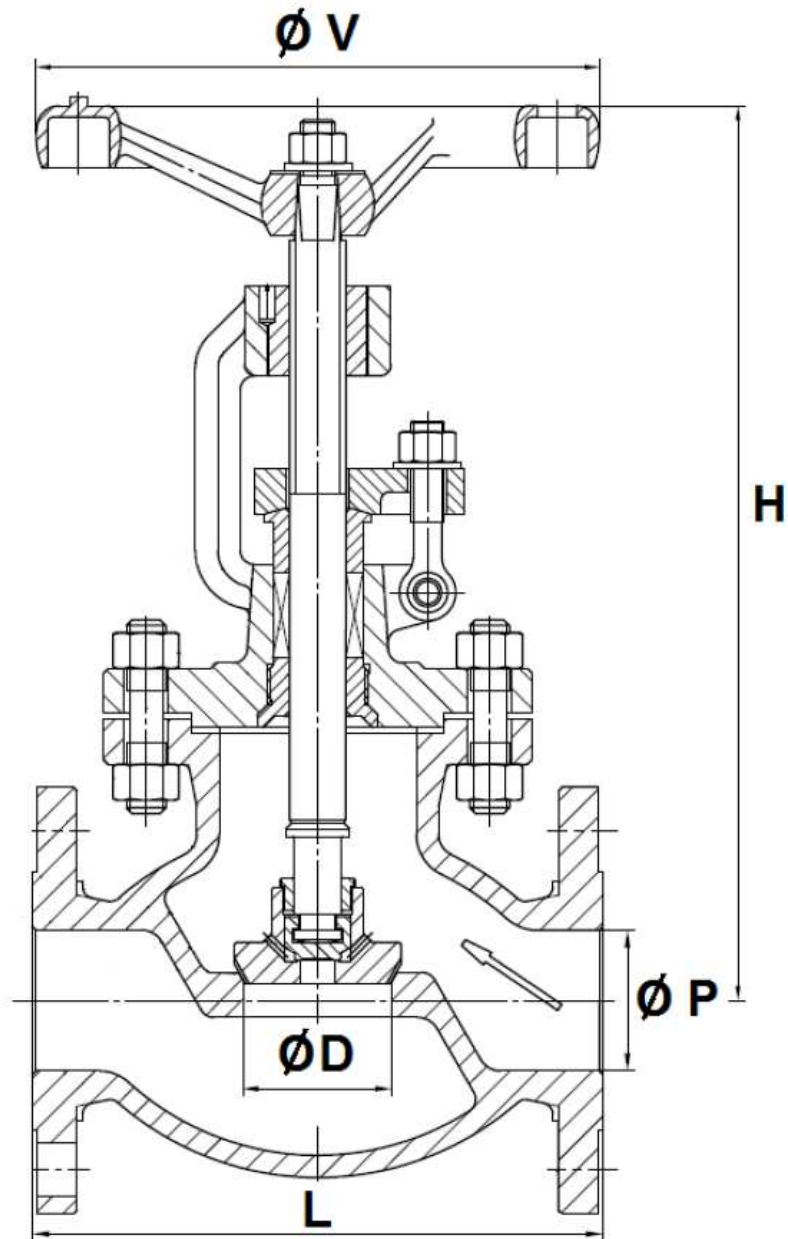

Ref.	DN ( mm )	200	250	300
	NPS ( " )	8"	10"	12"
444	Ø P	203	254	305
	Ø D	200	245	290
	L	559	622	711
	H ( opened )	768	1065	1137
	H ( closed )	700	980	1035
	Ø V	500	600	600
	Weight (Kg)	240	360	550

# V30

V30 111.444 class300 DN2" – DN12"  
Globe valve flange ANSI

FLANGES SIZE ( in mm ):

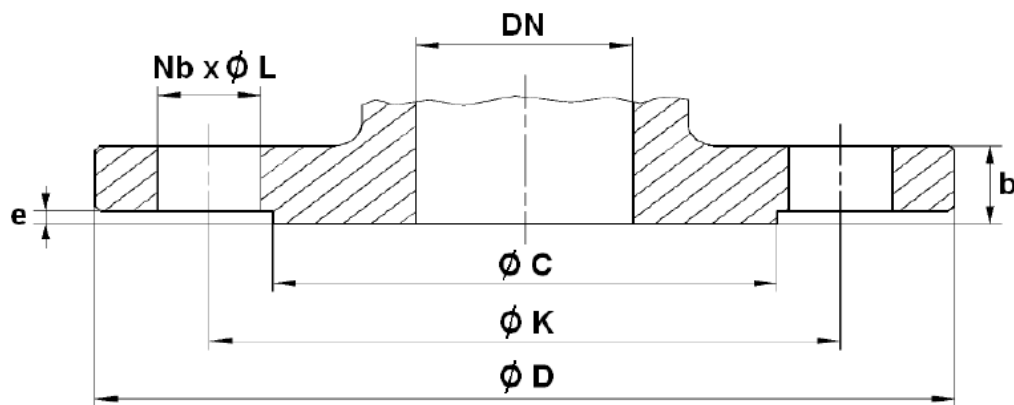

DN ( mm )	50	80	100	150	200	250	300
NPS ( " )	2"	3"	4"	6"	8"	10"	12"
Ø C	92.1	127	157.2	215.9	269.9	323.8	381
Ø D	165	210	255	320	380	445	520
Ø K	127	168.3	200	269.9	330.2	387.4	450.8
Nb x Ø L	8 x 19	8 x 22	8 x 22	12 x 22	12 x 26	16 x 29	16 x 32
b	22.7	29	32.2	37	41.7	48.1	51.3
e	2	2	2	2	2	2	2

# V30

## V30 111.444 class300 DN2" – DN12" Globe valve flange ANSI

### TORQUE VALUE ( in Nm without safety coefficient ) :

DN	50	80	100	150	200	250	300
NPS ( " )	2"	3"	4"	6"	8"	10"	12"
Torque ( Nm )	30	84	145	319	617	1600	1988

### NUMBER OF CYCLES TO CLOSE OR OPEN THE VALVE :

DN	50	80	100	150	200	250	300
NPS ( " )	2"	3"	4"	6"	8"	10"	12"
Number of cycles	5	5	7	9	9	11	13

### STANDARDS :

- Fabrication according to ISO 9001 : 2008 and ISO 14001 : 2004
- DIRECTIVE 2014/68/EU : CE N° 0036  
Risk category III Module H
- Certificate 3.1 on request
- Designing according to BS 1873
- Pressure Tests according to API 598, table 6
- Length according to ASME B16.10, table 2 A15 series and EN 558 series 21 (excepted DN200 8")
- Flanges R.F. according to ASME B16.05 Class 300
- ATEX Group II Category 2 G/2D Zone 1 & 21 Zone 2 & 22 ( optional marking )
- Materials according to NACE MR 01-75 on request



### INSTALLATION INSTRUCTIONS

#### GENERAL GUIDELINES :

- Ensure that the valves to be used are appropriate for the conditions of the installation (type of fluid, pressure and temperature).
- Be sure to have enough valves to be able to isolate the sections of piping as well as the appropriate equipment for maintenance and repair.
- Ensure that the valves to be installed are of correct strength to be able to support the capacity of their usage.
- **Installation of all circuits should ensure that their function can be automatically tested on a regular basis (at least two times a year).**

#### INSTALLATION INSTRUCTIONS :

- **Before installing the valves, clean and remove any objects from the pipes** (in particular bits of sealing and metal) which could obstruct and block the valves.
- **Ensure that both connecting pipes either side of the valve (upstream and downstream) are aligned (if they're not, the valves may not work correctly).**
- **Make sure that the two sections of the pipe (upstream and downstream) match, the valve unit will not absorb any gaps. Any distortions in the pipes may affect the tightness of the connection, the working of the valve and can even cause a rupture. To be sure, place the kit in position to ensure the assembling will work.**
- **If sections of piping do not have their final support in place, they should be temporarily fixed. This is to avoid unnecessary strain on the valve.**
- Tighten the bolts in cross.
- It's recommended to operate the valve ( open and close ) 1 to 2 times per year
- Tighten the gland packing at the first start of the installation ( with a moderate torque ) so that there's no leakage and the handwheel is easy to operate.
- Do not use tools to operate the handwheel
- Respect the flow direction indicated by the arrow