

C09

C09 402 740.387 SS DN15-DN100
Check valve wafer



Size : DN 15 to DN100
Ends : Between flanges PN40
Min Temperature : - 30°C
Max Temperature : + 300°C
Max Pressure : 40 Bars
Specifications : Spring type
All positions
Metal / metal

Materials : Stainless steel

SPECIFICATIONS :

- Spring type
- All positions (respect the flow direction indicated by the arrow)
- Short length
- Full stainless steel corrosion resistant and for high temperature
- Metal / metal tightness

USE :

- Chemical and pharmaceutical industries, petrochemical industries, hydraulic installation, compressed air, steam
- Min Temperature Ts : - 30°C
- Max Temperature Ts : + 300°C
- Max Pressure Ps : 40 bars (see graph under)

PRESSURE / TEMPERATURE GRAPH :

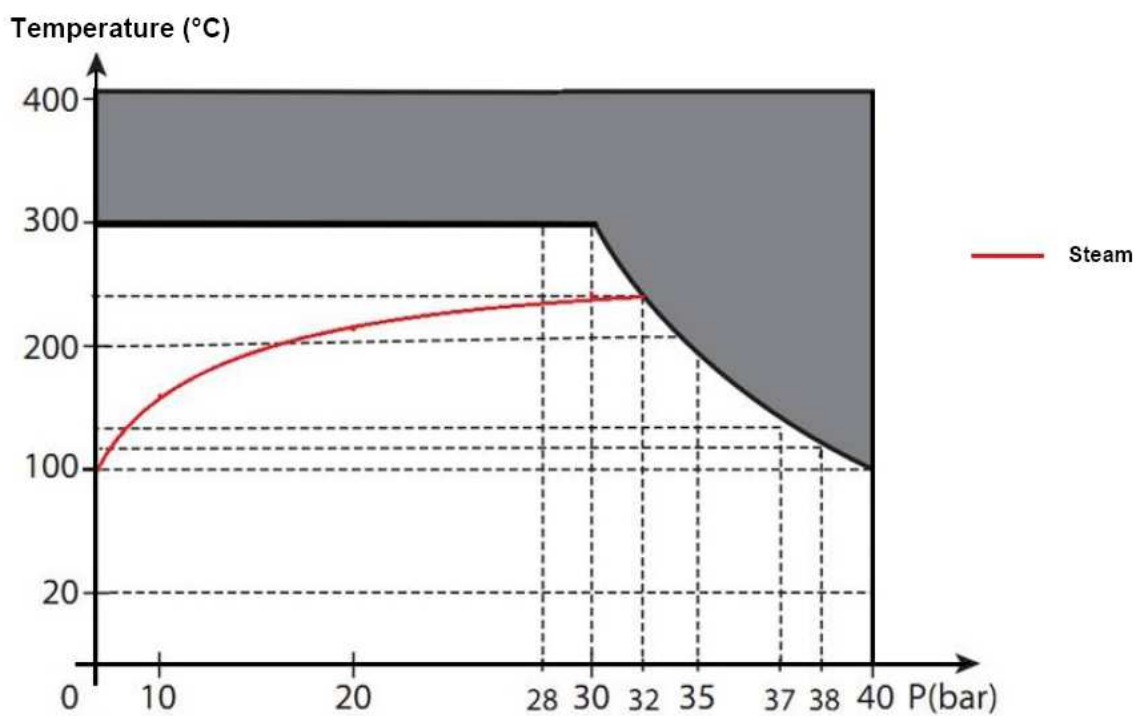

FLOW COEFFICIENT Kvs (M3 / h) :

DN	15	20	25	32	40	50	65	80	100
Kvs (m3/h)	1.2	2.2	3.2	4.8	7.2	11.8	17.8	23.7	39.5

RANGE :

- Stainless steel wafer spring check valve PN40 **Ref. 387** from DN15 to DN100

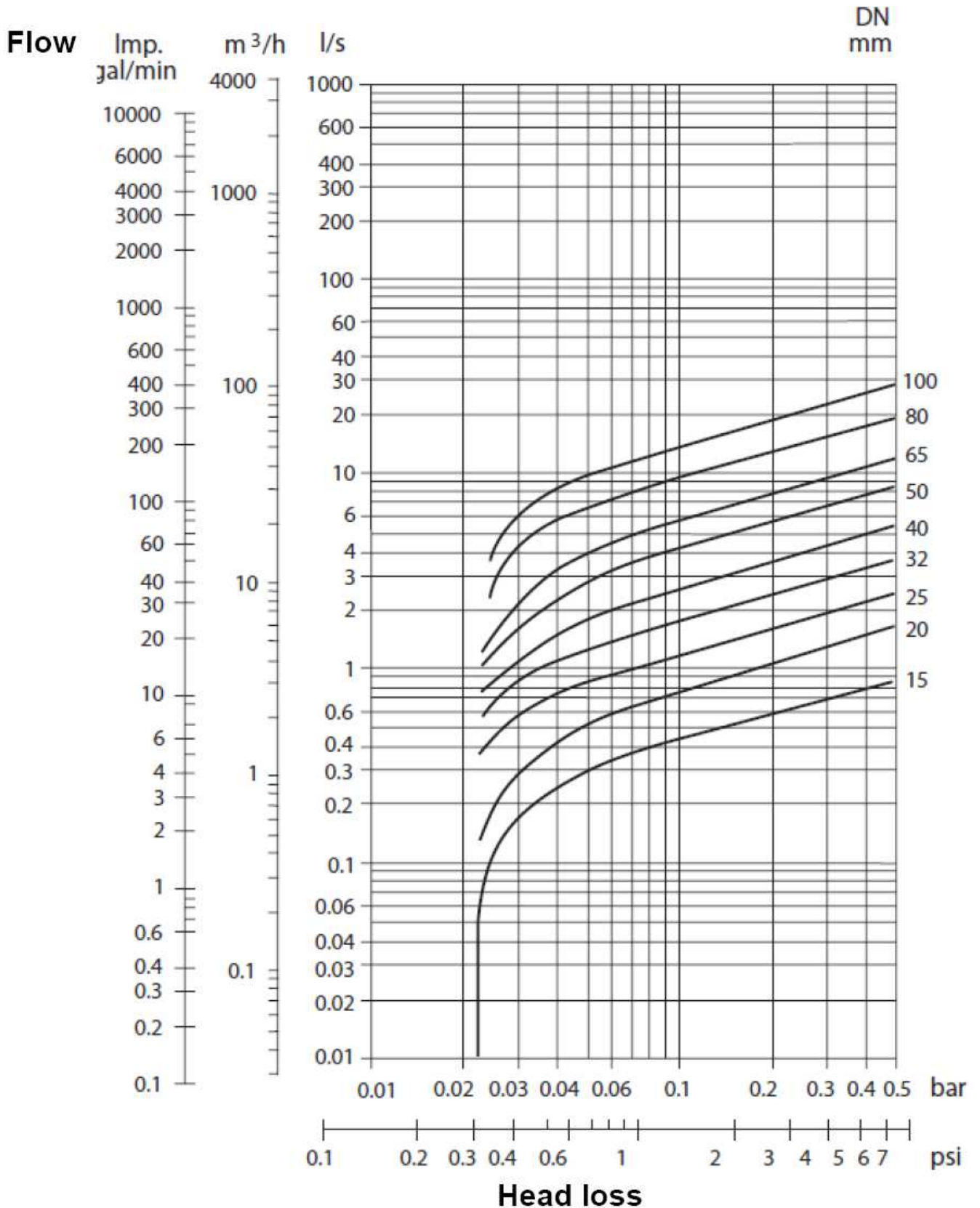

HEAD LOSS GRAPH :



C09

C09 402 740.387 SS DN15-DN100 Check valve wafer

OPENING PRESSURE (in mbar) :

DN	Vertical Position Ascendant fluid 	Horizontal position 
15	25	22.5
20	25	22.5
25	25	22.5
32	27	23.5
40	28	24
50	29	24.5
65	30	25
80	31	25.5
100	33	26.5

C09

C09 402 740.387 SS DN15-DN100
Check valve wafer

MATERIALS :

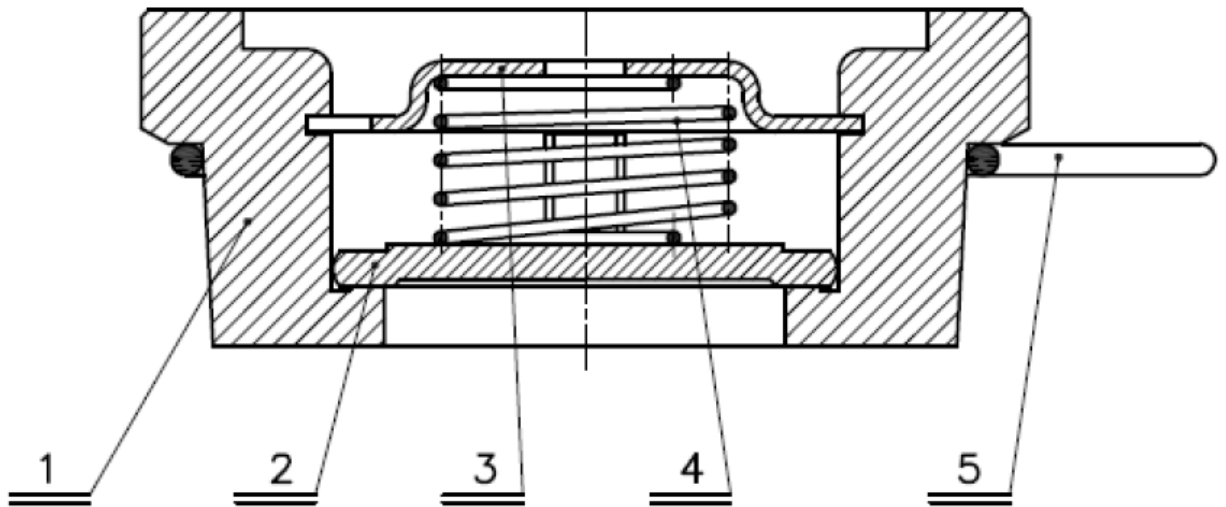

Item	Designation	Materials
1	Body	AISI 316
2	Disc	AISI 316
3	Spring holder	AISI 316
4	Spring	AISI 302
5	Centering ring	AISI 302

C09

C09 402 740.387 SS DN15-DN100
Check valve wafer

SIZE (in mm) :

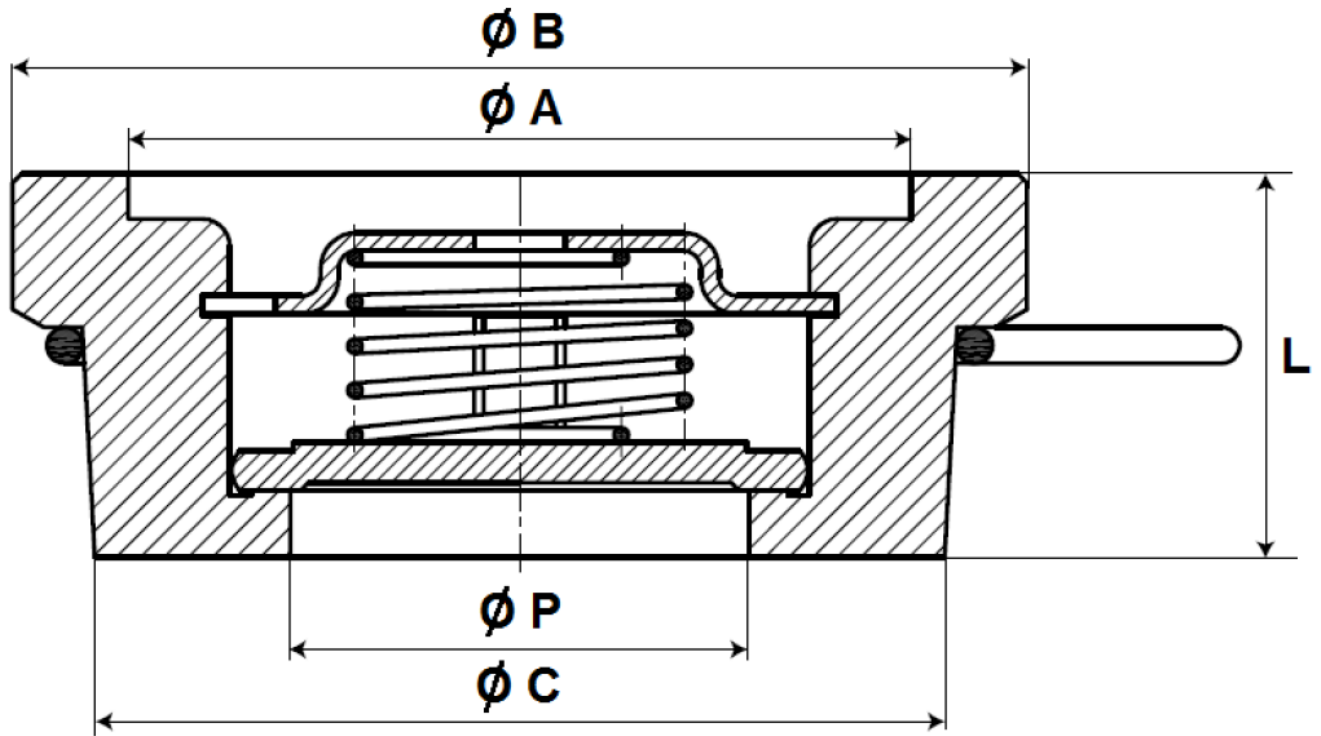

Ref.	DN	15	20	25	32	40	50	65	80	100
387	Ø A	28.3	35.7	43.2	52.4	63.1	75.4	96.2	109	125.3
	Ø B	39	46	54	70	80	96	113	130	150
	Ø C	33.5	41.2	48.3	62	74.5	87.5	107	126.3	145
	Ø P	15	20	25.3	31.7	39.3	48	62	75	85
	L	16	19	21	27.2	31	40	46	50	60
	Weight (Kg)	0.100	0.140	0.183	0.373	0.573	0.958	1.30	2.312	3.556

STANDARDS :

- Fabrication according to ISO 9001 : 2008
- DIRECTIVE 97/23/CE : CE N° 0036
Risk Category II Module A1
- Construction according to EN 12334
- Designing according to EN 14341
- Pressure tests according to EN 12266-1, range A
- Length according to EN 558 series 49

INSTALLATION POSITIONS :

Vertical position (ascendant fluid)

Horizontal position

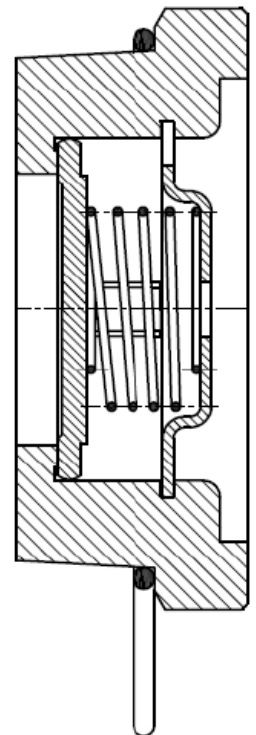
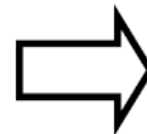
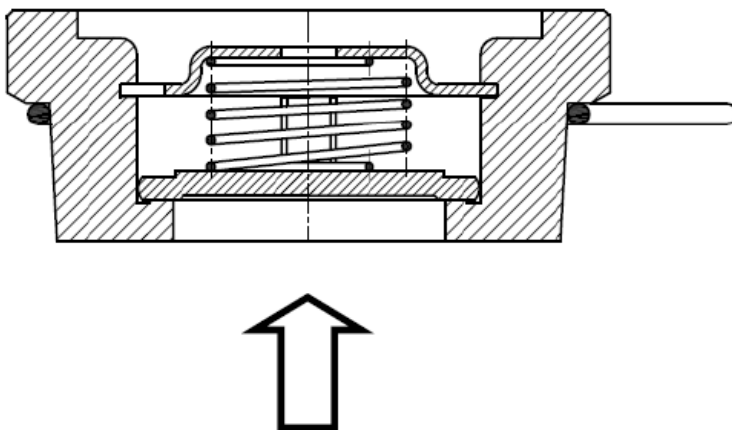

INSTALLATION INSTRUCTIONS

GENERAL GUIDELINES :

- Ensure that the check valves to be used are appropriate for the conditions of the installation (type of fluid, pressure and temperature).
- Be sure to have enough valves to be able to isolate the sections of piping as well as the appropriate equipment for maintenance and repair.
- Ensure that the valves to be installed are of correct strength to be able to support the capacity of their usage.

INSTALLATION INSTRUCTIONS :

- **Before installing the check valves, clean and remove any objects from the pipes** (in particular bits of sealing and metal) which could obstruct and block the valves.
- **Ensure that both connecting pipes either side of the check valve (upstream and downstream) are aligned** (if they're not, the valves may not work correctly).
- **Make sure that the two sections of the pipe (upstream and downstream) match, the check valve unit will not absorb any gaps. Any distortions in the pipes may affect the tightness of the connection, the working of the check valve and can even cause a rupture.** To be sure, place the kit in position to ensure the assembling will work.
- Make sure there is enough space so that the disc can be opened totally in the pipe.
- If there is a direction changing or if there's another material, it's better to take away the check valve so that it is outside the turbulence area (**between 3 and 5 times the ND before and after**).
- After a pump please refer to **FD CEN/TR 13932** to install the check valve :
 - If it is essential to keep priming the pump, a non-return check valve can be fitted to the suction pipe at a distance **L1 (straight length suction) > 10xD1 (diameter suction)**
The check valve is designed to meet the maximum flow rate in service
 - In other cases, the non-return check valve is mounted on the discharge pipe at a distance of **L2 (straight length at discharge) > 3xD2 (diameter at discharge)**