

S76.1

S76.1.177 EPDM PN10 DN50 – DN500 Knife gate valve wafer –bi directional tightness



Certificate 3.1

Size : DN 50 to DN 500
Ends : Between flanges PN10
Min Temperature : -15°C for EPDM seat
Max Temperature : + 110°C for EPDM seat
Max Pressure : 10 Bars up to DN 200
Specifications : Non rising stem and handwheel
Bidirectional tightness
Weak head loss

Materials : Cast iron body

S76.1

S76.1.177 EPDM PN10 DN50 – DN500 Knife gate valve wafer –bi directional tightness

SPECIFICATIONS :

- Opened or closed valve
- Non rising stem and handwheel
- Bidirectional tightness
- Weak head loss
- Between flanges PN10
- Full crossing threaded lower holes and blind threaded top holes
- With handwheel
- With lever or chain handwheel (option)
- 50% epoxy 50% polyester painting blue colour RAL 5005, 150 µm thickness

USE :

- Water, water treatment, chemical pulp, powders, food industry, chemistry
- Min and max Temperature Ts : - 15°C to + 110°C for valve with EPDM seat Ref.177
- Min and max Temperature Ts : - 10°C to + 180°C for valve with FKM seat (on request)

MAX PRESSURE :

DN	50	65	80	100	125	150	200	250	300	350	400	450	500
Ps (Bars)	10	10	10	10	10	10	10	8	6	4	4	3	3

MIN AND MAX SEAT TEMPERATURES WITH REFERENCES :

SEAT	TEMPERATURE	DN 50	DN 65	DN 80	DN 100	DN 125	DN 150	DN 200	DN 250	DN 300
NBR	-10°C to +90°C	9802240	9802241	9802242	9802243	9802244	9802245	9802246	9802247	9802248
EPDM	-15°C to +110°C	9802260	9802261	9802262	9802263	9802264	9802265	9802266	9802267	9802268
FKM	-10°C to +180°C	9802280	9802281	9802282	9802283	9802284	9802285	9802286	9802287	9802288

SEAT	TEMPERATURE	DN 350	DN 400	DN 450	DN 500
NBR	-10°C to +90°C	9802249	9802250	9802251	9802252
EPDM	-15°C to +110°C	9802269	9802270	9802271	9802272
FKM	-10°C to +180°C	9802289	9802290	9802291	9802292

S76.1

S76.1.177 EPDM PN10 DN50 – DN500 Knife gate valve wafer –bi directional tightness

RANGE :



- Between flanges PN10, Cast iron body, SS 304 gate , EPDM seat, with handwheel **Ref. 177** from DN 50 to DN 500



- Between flanges PN10 Cast iron body, SS 304 gate , EPDM seat, with handwheel, with limit switch for opened position **Ref. 177051 to 177401** from DN 50 to DN 400



- Chain handwheel (on request)
 - **Ref. 9801796** from DN 50 to DN 150
 - **Ref. 9801797** from DN 200 to DN 300
 - **Ref. 9801798** from DN 350 to DN 500



- Chain (per meter) **Ref. 9801795**



- Stainless steel support with bolting **Ref. 9802001 to 9802011** from DN 50 to DN 400

S76.1

S76.1.177 EPDM PN10 DN50 – DN500 Knife gate valve wafer –bi directional tightness

MATERIALS :

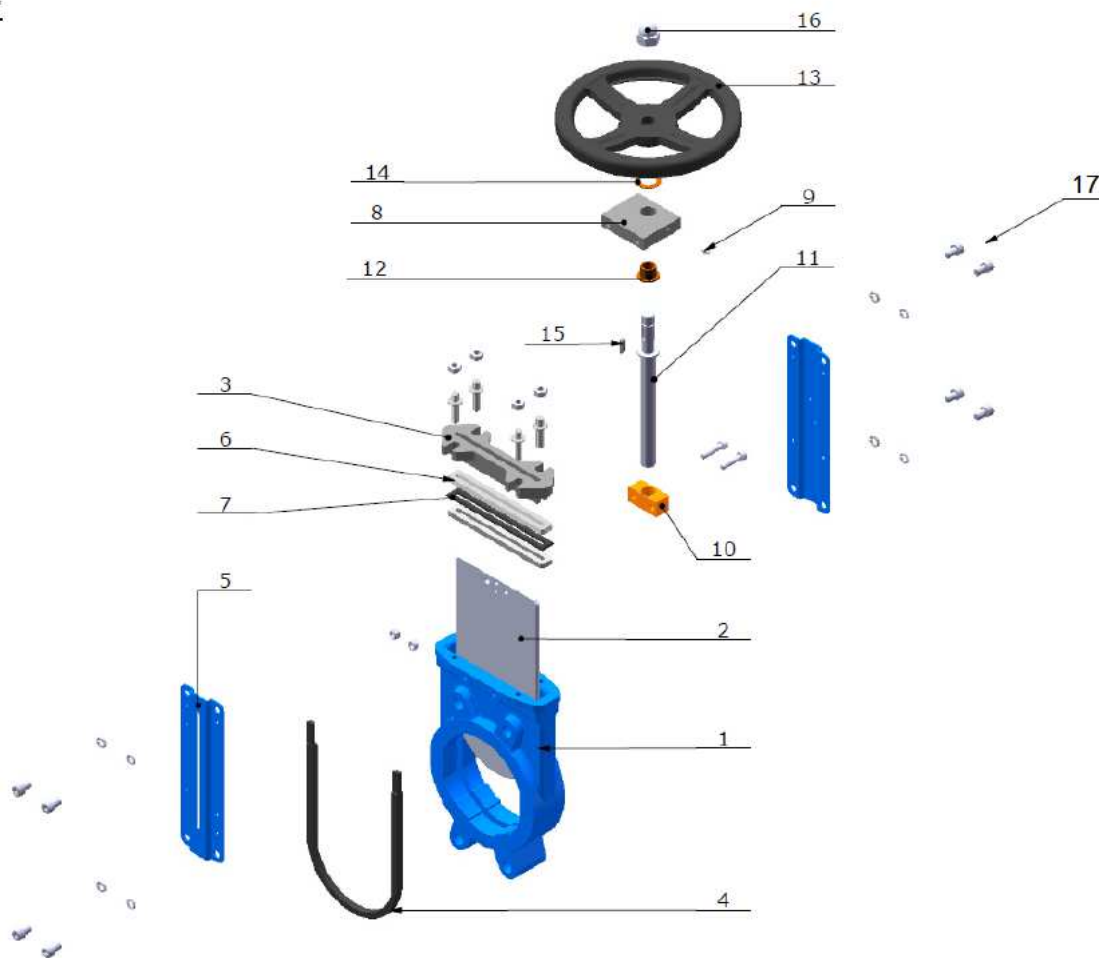

Item	Designation	Materials
1	Body	Cast iron EN GJL-250
2	Gate	AISI 304
3	Packing gland	Ductile Iron EN GJS-400-15
4	Seat	EPDM
5	Support	Painted steel
6	Packing (Tress)	PTFE
7	Packing (O ring)	EPDM
8	Yoke	A3 Steel
9	Greaser	Steel
10	Stem nut	Bronze
11	Stem	AISI 304
12	Stem nut	Bronze
13	Handwheel	A3 Steel
14	Ring	Bronze
15	Pin	Steel
16	Handwheel nut	Zinc-coated Steel
17	Bolting	Zinc-coated 8.8 steel

S76.1

S76.1.177 EPDM PN10 DN50 – DN500 Knife gate valve wafer –bi directional tightness

SIZE (in mm) :

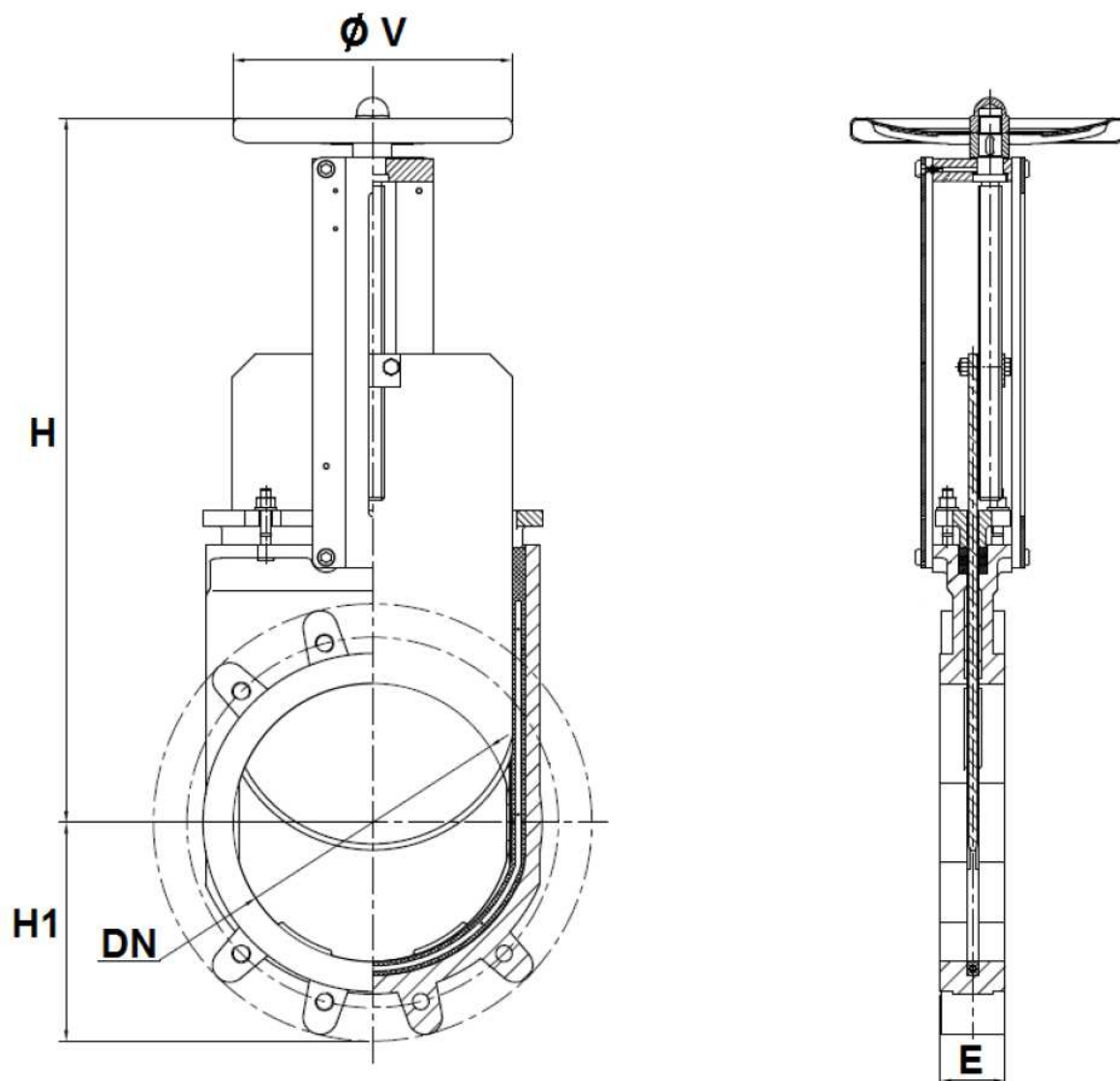

DN	50	65	80	100	125	150	200	250	300	350	400	450	500
E	40	40	50	50	50	60	60	70	70	96	100	106	110
H	286	316	342	382	415	458	575	676	776	906	1012	1098	1210
H1	63	70	92	105	120	130	160	198	234	256	292	308	340
Ø V	200	200	200	200	250	250	300	300	300	500	500	500	500
Weight (Kg)	6.2	6.8	8	9.9	12.7	16.9	25.4	42.7	59	119	144	166	203

S76.1

S76.1.177 EPDM PN10 DN50 – DN500 Knife gate valve wafer –bi directional tightness

SIZE FIXING VALVE THREADED HOLES (BETWEEN FLANGES PN10 in mm) :

DN 50 – 65

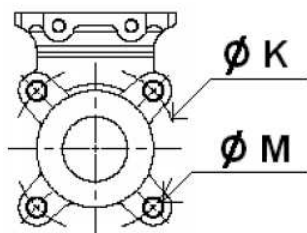

DN 80 – 200

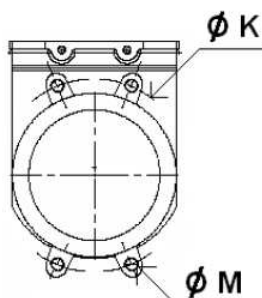

DN 250 - 300

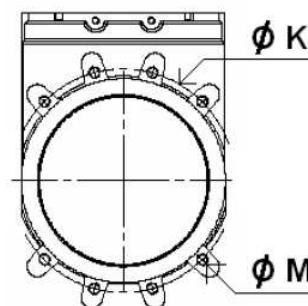

DN 350

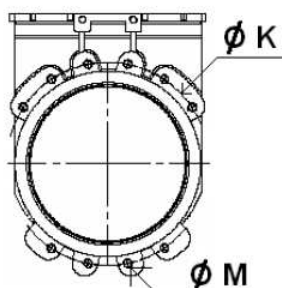

DN 400

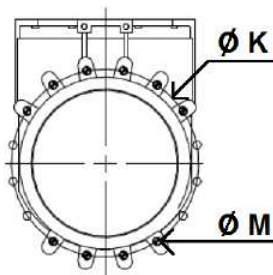

DN 450-500

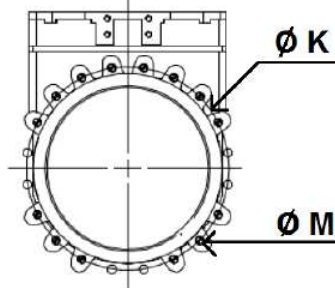

THREADED LENGHT FOR TOP BLIND HOLES :

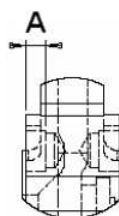

DN	50	65	80	100	125	150	200	250	300	350	400	450	500
Ø K	125	145	160	180	210	240	295	350	400	460	515	565	620
Ø M	M16	M16	M16	M16	M16	M20	M20	M20	M20	M20	M24	M24	M24
Nb threaded hole	4	4	4	4	4	4	4	8	8	10	10	14	14
A	8	8	9	9	9	10	10	12	12	20	20	24	24

SENSOR SIZE (in mm) AND SCHEMA :

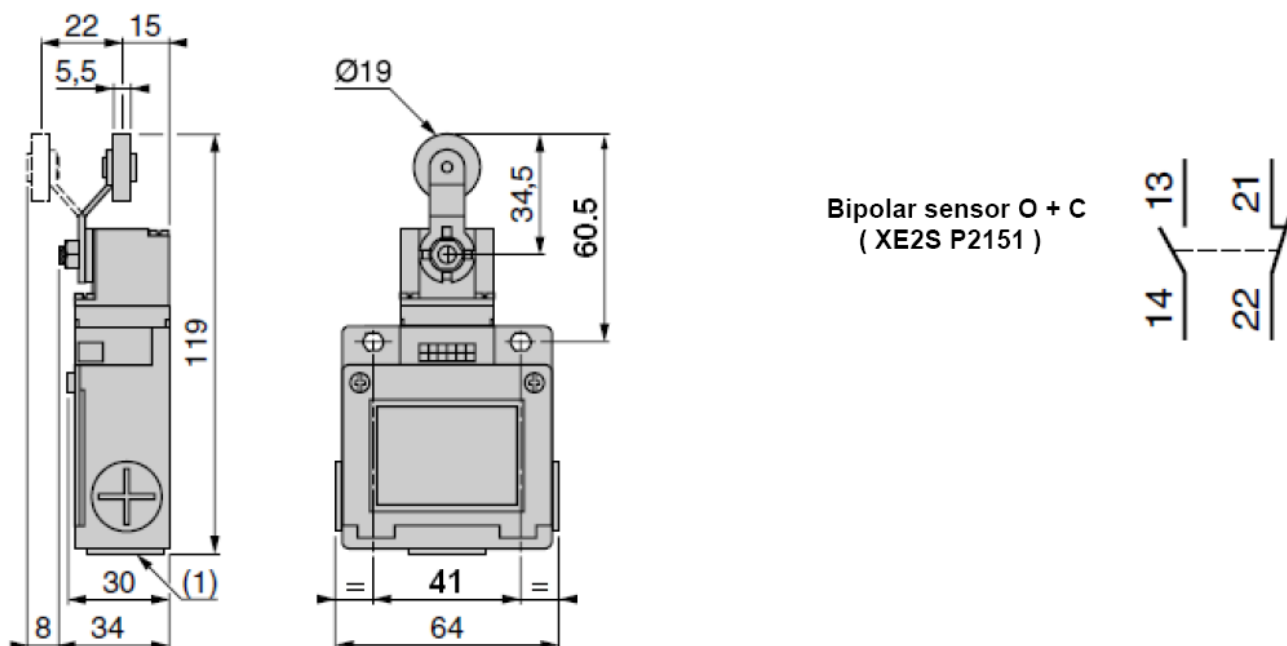

STANDARDS :

- Fabrication according to ISO 9001 : 2008
- DIRECTIVE 97/23/CE : Risk category I Module A
- Certificate 3.1 on request
- Pressure test according to ISO 5208, Range A
- Between flanges PN10 according to EN 1092-2 PN10

INSTALLATION INSTRUCTIONS :

GENERAL GUIDELINES :

- Ensure that the valves to be used are appropriate for the conditions of the installation (type of fluid, pressure and temperature).
- Be sure to have enough valves to be able to isolate the sections of piping as well as the appropriate equipment for maintenance and repair.
- Ensure that the valves to be installed are of correct strength to be able to support the capacity of their usage.
- Installation of all circuits should ensure that their function can be automatically tested on a regular basis (at least two times a year).

INSTALLATION INSTRUCTIONS :

- Before installing the valves, clean and remove any objects from the pipes (in particular bits of sealing and metal) which could obstruct and block the valves.
- Ensure that both connecting pipes either side of the valve (upstream and downstream) are aligned (if they're not, the valves may not work correctly).
- Make sure that the two sections of the pipe (upstream and downstream) match, the valve unit will not absorb any gaps. Any distortions in the pipes may affect the tightness of the connection, the working of the valve and can even cause a rupture. To be sure, place the kit in position to ensure the assembling will work.
- If sections of piping do not have their final support in place, they should be temporarily fixed. This is to avoid unnecessary strain on the valve.
- During installation operation, do not carry the valves by the handwheel.
- Valves can be installed in all positions but we recommend the above positions :

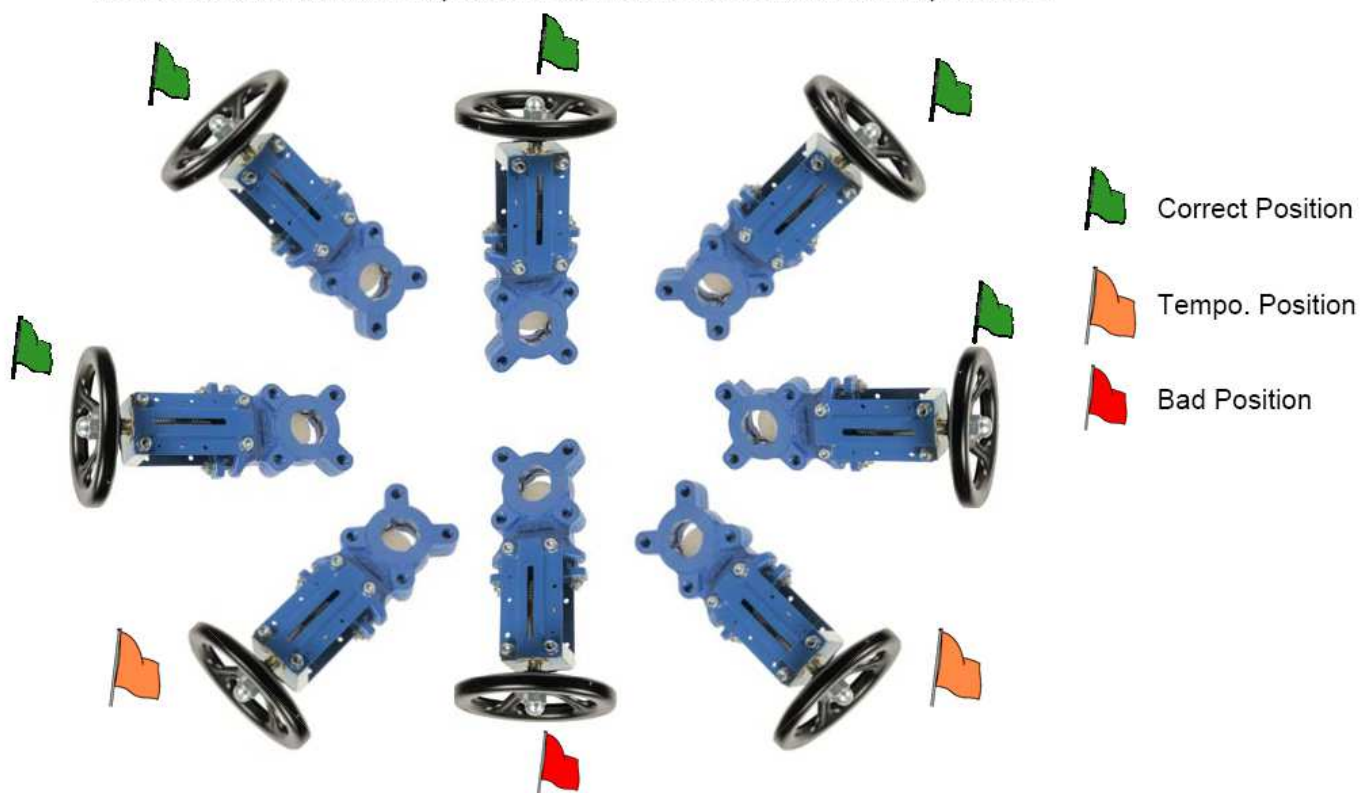

INSTALLATION INSTRUCTIONS (SUITE) :

- If the valve is installed at the end of the pipe, it must be between 2 flanges.
- Tighten the bolts in cross. For blind holes, use studs to have a good tightening and tighten them carefully so that they don't touch the gate.
- During cleaning operation, the valves must be opened.
- Tests must be done with cleaned installation and pipe.
- Test must be done with partially opened valve. Test pressure must not exceed valve specification according to ISO 5208.
- Open carefully the valve.
- Tighten the gland packing at the first start of the installation (with a moderate torque) so that there's no leakage and the handwheel is easy to operate. Make sure there's no contact between the gate and the gland.
- Keep greased the stem.
- It's recommended to operate the valve (open and close) 1 time per month