

K85

K85 131 040.780 T port DN1/4" - 2"
Ball valve 3 way threaded BSP



Size : DN 1/4" to 2"
Ends : Threaded BSP
Min Temperature : -30°C
Max Temperature : + 140°C
Max Pressure : 40 Bars
Specifications : ISO 5211 mounting pad
PTFE seat
Anti blow-out stem

Materials : Stainless steel

SPECIFICATIONS :

- Reduced bore
- Anti blow-out stem
- PTFE seat
- Locking device
- ISO 5211 mounting pad
- Tightness on 3 ways
- L or T port

USE :

- Chemical and pharmaceutical industries, petrochemical industries, hydraulic installation, compressed air
- Min and max Temperature Ts : -30°C to + 140°C
- Max Pressure Ps : 40 bars (see graph)

PRESSURE / TEMPERATURE GRAPH (STEAM EXCLUDED) :

PRESSURE

BAR

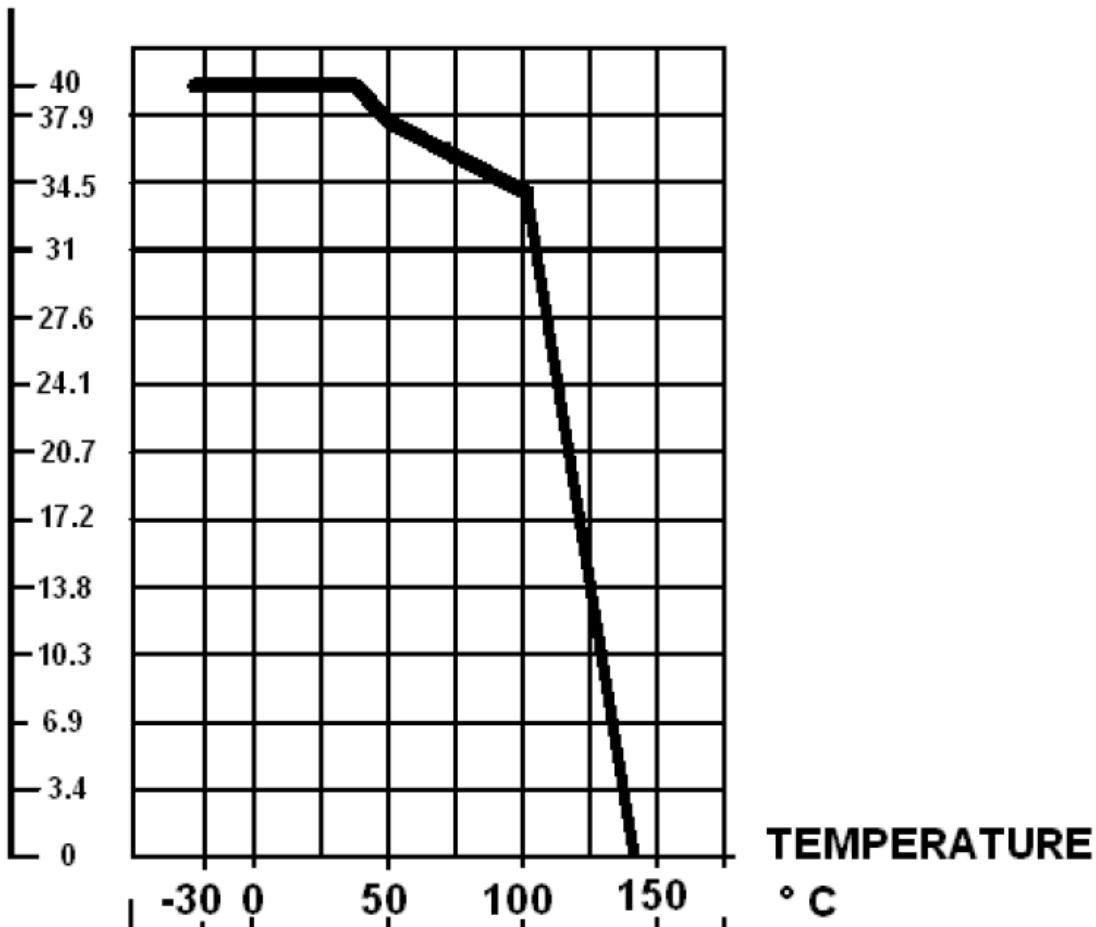

K85

K85 131 040.780 T port DN1/4" - 2" Ball valve 3 way threaded BSP

RANGE :

- Stainless steel with L port **Ref. 780** from DN 1/4" to 2"
- Stainless steel with T port **Ref. 781** from DN 1/4" to 2"

ENDS :

- Threaded BSP female cylindrical

MATERIALS :

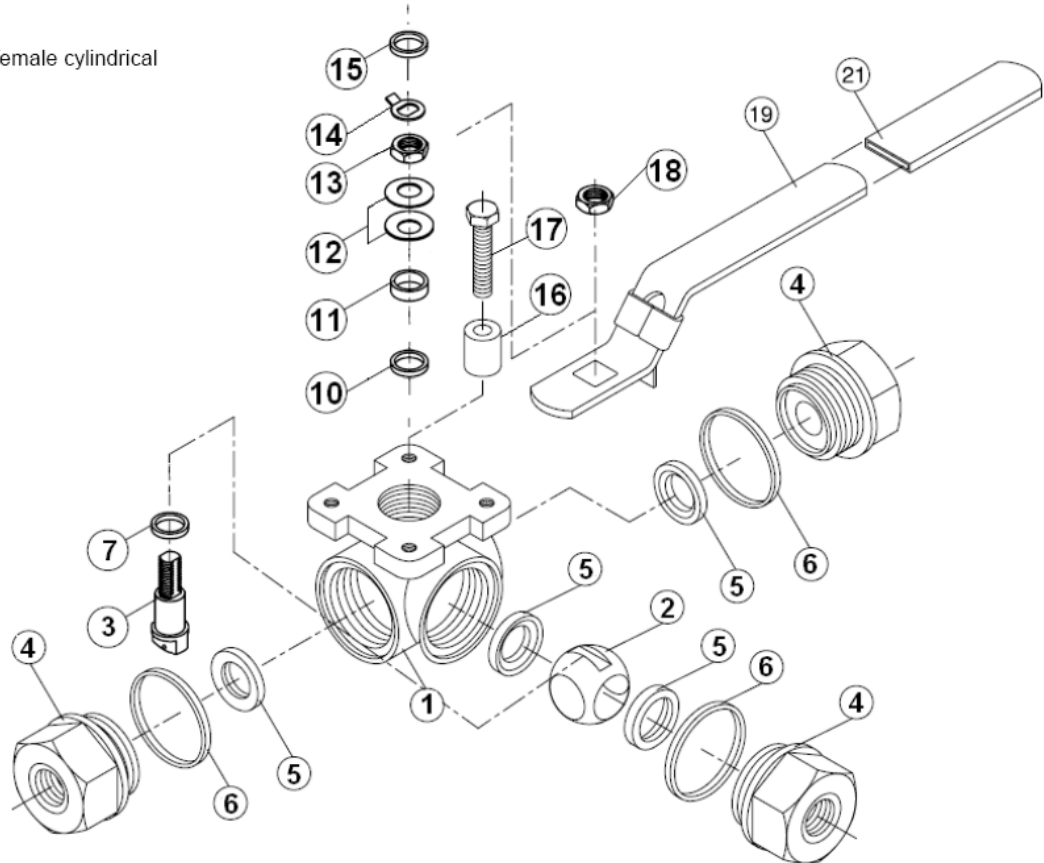

Item	Designation	Materials
1	Body	ASTM A351 CF8M
2	Ball	ASTM A351 CF8M
3	Stem	SS 316
4	Ends	ASTM A351 CF8M
5*	Seat	PTFE
6*	Body seal	PTFE
7*	Stem gasket	PTFE + 3% glass fiber
10*	Packing	PTFE
11	Gland	SS 301
12	Elastic ring	SS 304
13	Packing nut	8
14	Washer	SS 304
15	Handle washer	SS 301
16	Stop pin	8
17	Pin screw	8M
18	Handle nut	8
19	Handle	SS 201
21	Handle cover	Plastic





(* : Included in gaskets kit)

K85

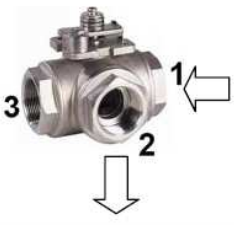
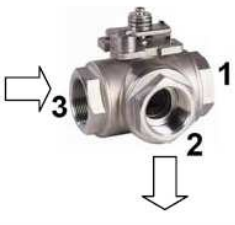

K85 131 040.780 T port DN1/4" - 2"
Ball valve 3 way threaded BSP

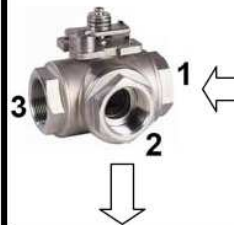
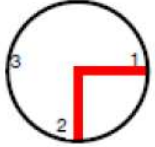
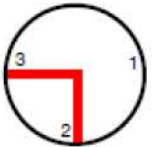
POSSIBLES POSITIONS :

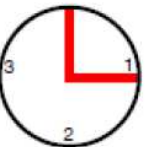
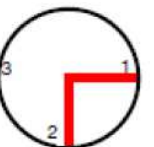
L Port (only 2 consecutive positions are possibles)

Position L1	Position L2	Position L3	Position L4	Position L5
				
				

T Port (only 2 consecutive positions are possibles)

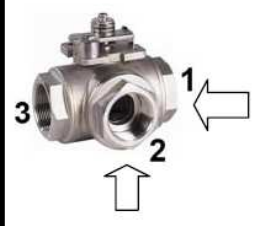
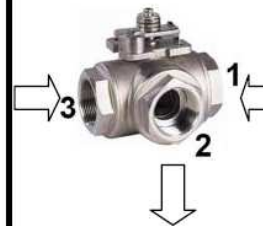
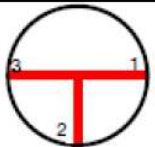
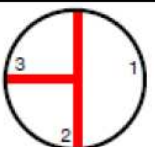
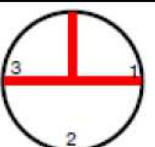
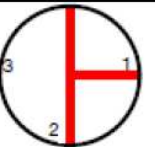
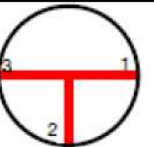
Position T1	Position T2	Position T3	Position T4	Position T5
				
				

K85

K85 131 040.780 T port DN1/4" - 2" Ball valve 3 way threaded BSP

SIZE (in mm) :

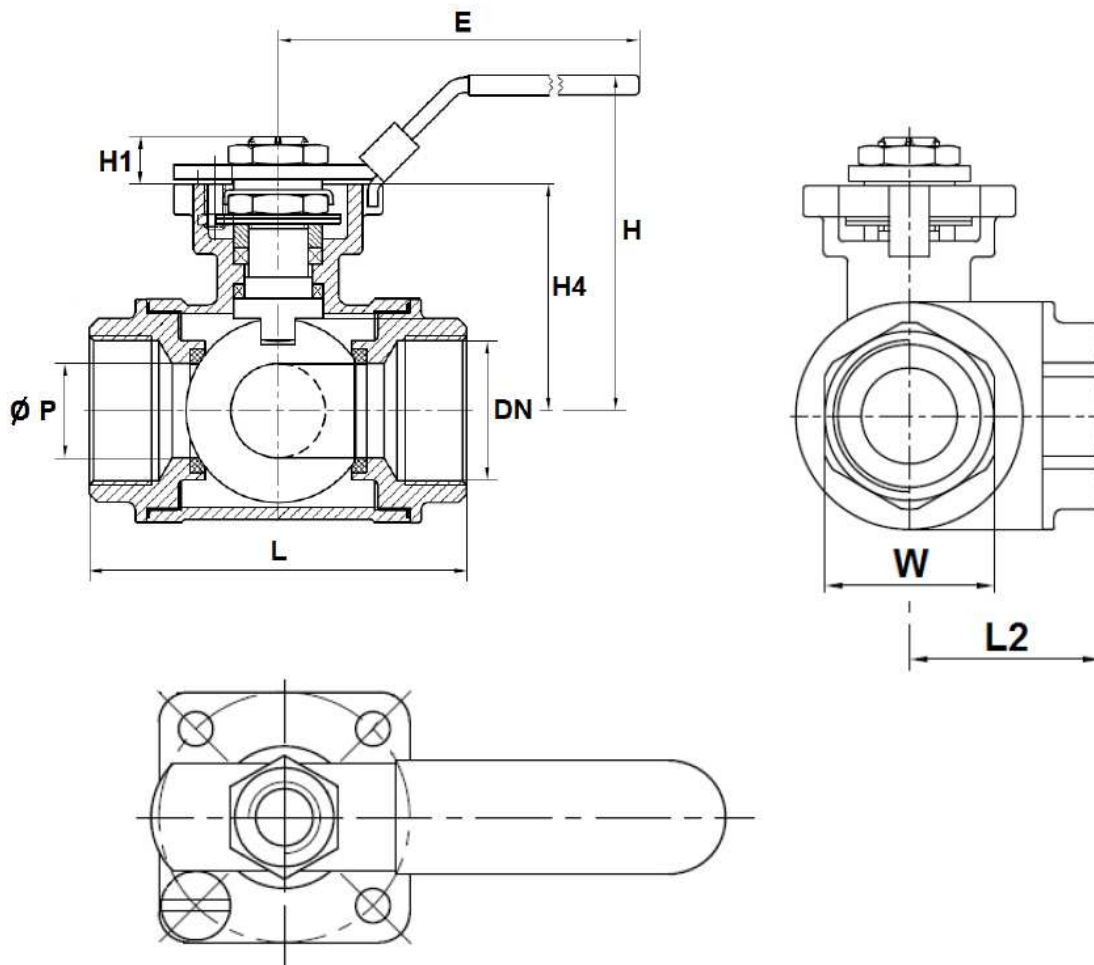

Ref.	DN	1/4"	3/8"	1/2"	3/4"	1"	1"1/4	1"1/2	2"
780 / 781	Ø P	6	8	10	15	18	25	32	38
	L	73	73	73	84	90	124	135	152
	L2	36.5	36.5	36.5	42	45.3	62	67.5	76
	E	125	125	125	145	145	163	190	190
	H	67	67	67	77	80	94	108	116
	H1	10	10	10	12.5	12.5	13	16	16
	H4	36	36	36	42	49	55.5	70	77.5
	W (on flat)	25	25	25	32	38	47.5	55	67
	Weight (Kg)	0.66	0.64	0.60	0.90	1.12	2.18	3.30	4.82

K85

K85 131 040.780 T port DN1/4" - 2"
Ball valve 3 way threaded BSP

ISO MOUNTING PAD AND STEM SIZE (in mm) :

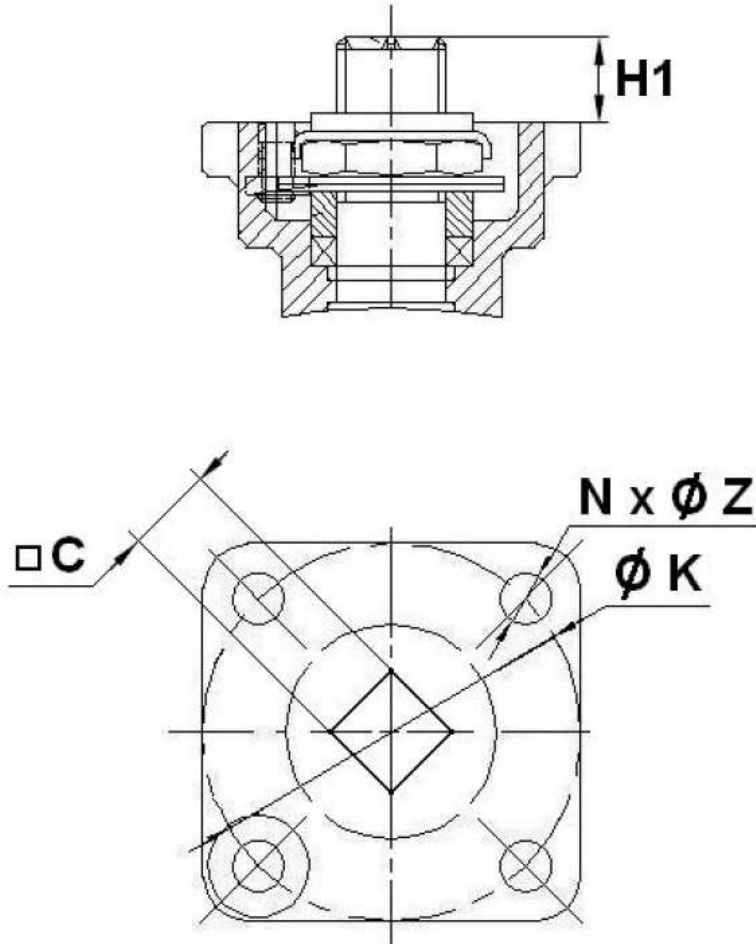

Ref.	DN	1/4"	3/8"	1/2"	3/4"	1"	1"1/4	1"1/2	2"
780 / 781	C	9	9	9	11	11	11	14	14
	H1	10	10	10	12.5	12.5	13	16	16
	Ø K	42	42	42	50	50	50	70	70
	ISO	F04	F04	F04	F05	F05	F05	F07	F07
	N x Ø Z	4 x 6	4 x 6	4 x 6	4 x 7	4 x 7	4 x 7	4 x 9	4 x 9

K85

K85 131 040.780 T port DN1/4" - 2" Ball valve 3 way threaded BSP

TORQUE VALUES (in Nm without safety coefficient) :

DN	1/4"	3/8"	1/2"	3/4"	1"	1"1/4	1"1/2	2"
Torque (Nm)	3	3	5	10	24	35	35	50

FLOW COEFFICIENT Kvs (M3 / H) :

REF.	DN	1/4"	3/8"	1/2"	3/4"	1"	1"1/4	1"1/2	2"
780	Kvs (M3 / H)	3.51	3.63	4.86	8.28	13.49	21.55	36.14	53.57
781	Kvs (M3 / H)	4.97	5.14	6.88	11.71	19.07	30.47	51.1	75.76

STANDARDS :

- Fabrication according to ISO 9001 : 2008
- DIRECTIVE 97/23/CE : CE N° 0035
Risk Category II Module D1
- Construction according to EN 12516
- Designing according to EN 10213
- Pressure tests according to EN 12266-1, Range A
- Threaded BSP cylindrical ends according to ISO 228-1
- ISO 5211 mounting pad

K85

**K85 131 040.780 T port DN1/4"- 2"
Ball valve 3 way threaded BSP**

INSTALLATION AND MAINTENANCE

BEFORE INSTALLATION :

Pipe-line must be cleaned and free from residual of weldings, rubbish, shaving and every kind of extraneous materials.
Pipe-line must be perfectly aligned and their support properly dimensioned so that there's no external constraint.

Please use the right product according to the services conditions to seal the valve.
Use the right bolt tightening so that the ends won't be damaged.

CLEANING AND TESTS

Keep closed the valves during the cleaning operation so that there's no impurities between the ball and the body.

Tests under pressure must be done with a cleaned pipe-line.

Open partially the valve for tests. Pressure test do not exceed the valve specifications according to EN 12266-1.

MAINTENANCE

It's recommended to operate the valve twice (open and close) 1 to 2 times per year.

When intervention on the valve, be sure there's no pressure in the pipe-line, there's no fluid in it, and that it is isolated.
The temperature must be low enough to operate without risks.
If there's a corrosive fluid, inert installation before intervention.

When the valve is under pressure :

If there's a leakage at the packing, tighten it slightly so that the leakage disappears.