

## D73h 118 440 – STRAINER FLANGED

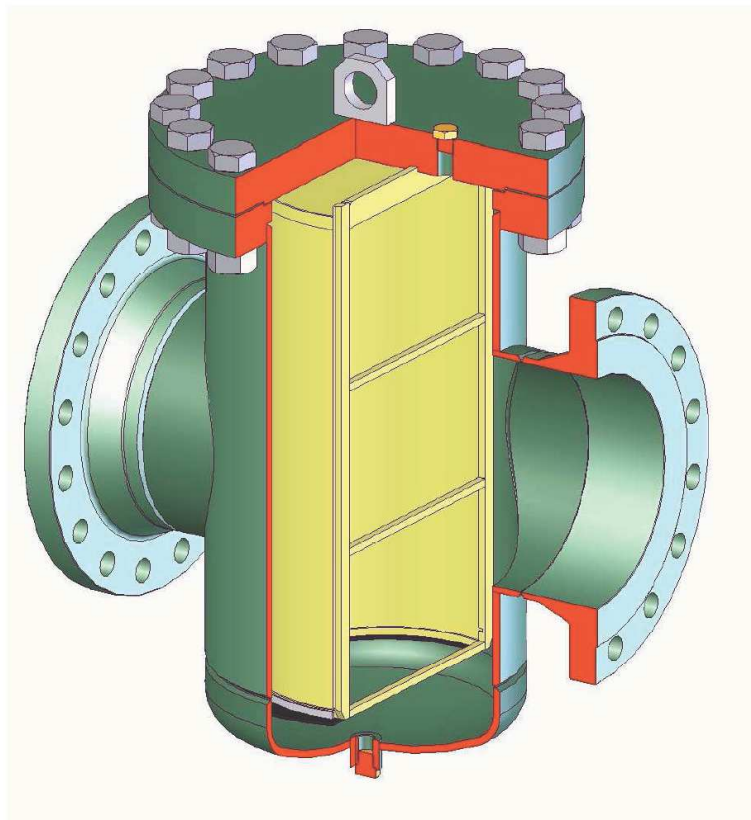

TYPE / ТИП	D73
Nominal pressure/ номинальное давление	PN 16
Nominal size/ номинальный размер	DN 100 – 300

Filter range
6 µm – 10 mm

Design / конструкция	EN 13709
Flanges / фланцы	EN 1092-1
Welding end / концы под приварку	EN 12627
Face-to-face/ стр.длина	DIN 3202
Testing/ испытания	EN 12266-1
Pressure/Temperature Давление/Температура	EN 12516-1

Pos	Part / деталь	Material / материал			
		-29 - +400 °C	-20 - +593 °C	-47 - +340 °C	-70 - +350 °C
		DIN (ASTM)	DIN (ASTM)	DIN (ASTM)	DIN (ASTM)
1	Body / корпус	C22.8 (A105) GS-C25 (WCB)	13CrMo44 (F11) GS-17CrMo5-5 (WC6)	TSTE 355 (LF2) GS-20Mn5 (LCB)	X5CrNi18-9 (F304) GX5CrNi 18-9 (CF8)
2	Bonnet / крышка	C22.8(A105) GS-C25 (WCB)	13CrMo44(F11) GS-17CrMo5-5 (WC6)	TSTE 355 (LF2) GS-20Mn5 (LCB)	X5CrNi18-9(F304) GX5CrNi 18-9 (CF8)
3	Filter element / фильтрационный элемент	X5CrNi18-9(F304)	X5CrNi18-9(F304)	X5CrNi18-9(F304)	X5CrNi18-9(F304)
4	Filter ring	X5CrNi18-9(F304)	X5CrNi18-9(F304)	X5CrNi18-9(F304)	X5CrNi18-9(F304)
5	Sealing /уплотнение	Spiral-graphite/SS	Spiral-graphite/SS	Spiral-graphite/SS	Spiral-graphite/PTFE/SS
6	Bolt / болт	A193 B7	A193 B7	A182 L7	A193 B7
7	Nut / гайка	A194 2H	A194 2H	A194 4	A194 2H

Other material specification upon request / другое исполнение по заказу

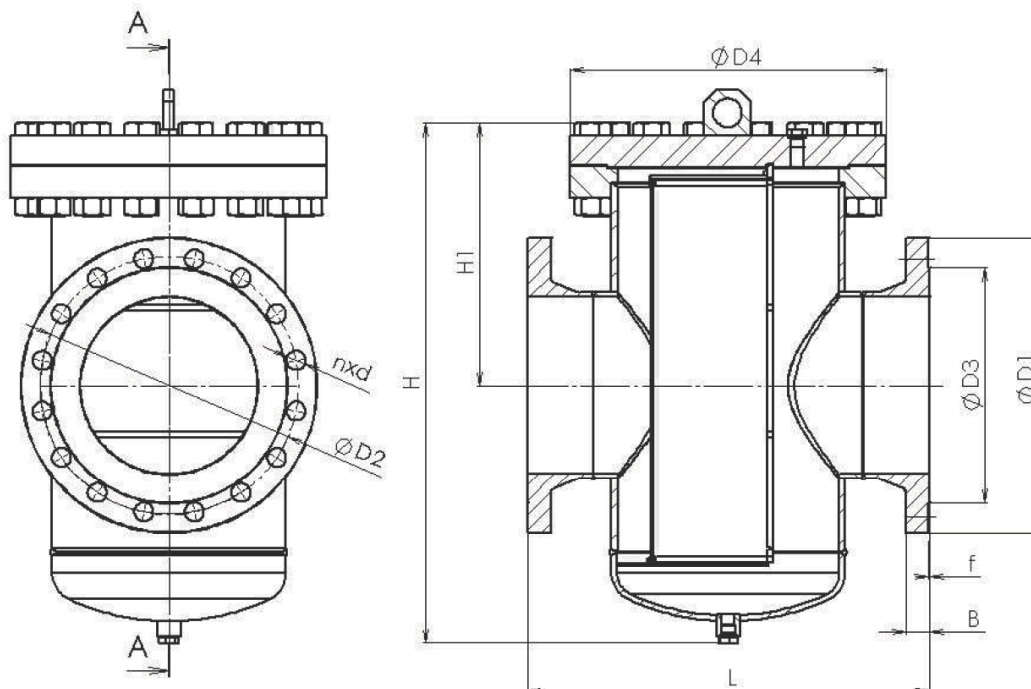

Main dimension PN16 / Основные размеры PN16						
DN	100	125	150	200	250	300
D1	220	250	285	340	405	460
D2	180	210	240	295	355	410
D3	158	188	212	268	320	378
D4	315	340	405	460	520	580
B	20	22	22	24	26	28
f	3	3	3	3	3	4
n	8	8	8	12	12	12
d	18	18	22	22	26	26
bolt	M16	M16	M20	M20	M24	M24
H1	200	220	275	320	305	380
H	380	475	550	560	690	830
L	350	400	480	600	600	700
m (kg)	50	63	97	138	190	231

