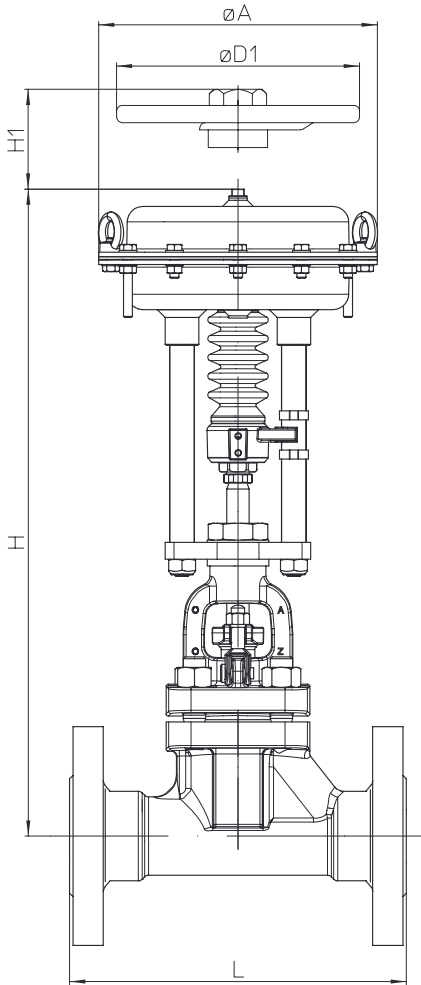
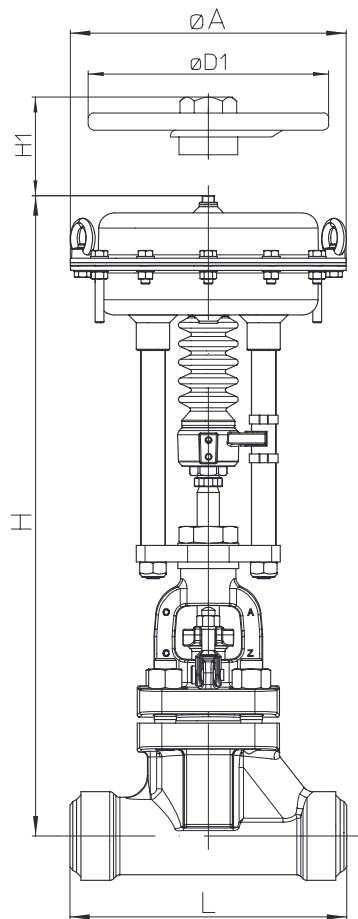

Stop valve in straightway form with gland packing with pneumatic actuator ARI-DP

Fig. 006

Fig. 005

Actuator data		DP32	DP33	DP34
Ø A	(mm)	250	300	405
Eff. diaphragm area	(cm ²)	250	400	800
Ø D1	(mm)	225	300	400
H1	(mm)	270	284	442
Weight	(kg)	5		17

Heights and weights

Technical data and accessories of actuators: refer to actuator data sheet

DN			10	15	20	25	32	40	50	65	80	100	125	150		
DP32	Fig. 006	H	(mm)	515	515	515	515	--	--	--	--	--	--	--	--	
		PN63-160	(kg)	18	18,2	19,8	20,8	--	--	--	--	--	--	--	--	--
	Fig. 005	H	(mm)	515	515	515	515	--	--	--	--	--	--	--	--	--
		PN63-160	(kg)	15,7	15,7	15,7	15,9	--	--	--	--	--	--	--	--	--
DP33	Fig. 006	H	(mm)	568	568	568	568	--	--	--	--	--	--	--	--	
		PN63-160	(kg)	24	24,2	25,8	26,8	--	--	--	--	--	--	--	--	--
	Fig. 005	H	(mm)	568	568	568	568	--	--	--	--	--	--	--	--	--
		PN63-160	(kg)	21,7	21,7	21,7	21,9	--	--	--	--	--	--	--	--	--
DP34	Fig. 006	H	(mm)	--	--	--	--	738	738	751	on request					
		PN63-160	(kg)	--	--	--	--	65	67	72,5						
	Fig. 005	H	(mm)	--	--	--	--	738	738	751						
		PN63-160	(kg)	--	--	--	--	59,2	59,2	61,7						

Fig. 006: Face-to-face dimension FTF serie 2 acc. to DIN EN 558

Standard-flange dimensions refer to page 16

Fig. 005: Face-to-face dimension ETE serie 65 acc. to DIN EN 12982

Valves with butt weld ends refer to page 16

Spring closes on air failure (Extended stem on air failure)

DN		10	15	20	25
Kvs-value	(m³/h)	2,7	4,2	6,4	8,6
max. differential press. ¹⁾	(bar)	2	2	2	2
Travel	(mm)	11	11	11	11
 DP32 250 cm²	Spring range (bar) 2-3,3 Air supply pressure min. (bar) 4,5 (bar)	40	40	40	40

Spring opens on air failure (Retracted stem on air failure)

DN		10	15	20	25
Kvs-value	(m³/h)	2,7	4,2	6,4	8,6
max. differential press. ¹⁾	(bar)	2	2	2	2
Travel	(mm)	11	11	11	11
 DP32 250 cm²	Air supply pressure min. (bar) 4,5 (bar)	40	40	40	40
	Air supply pressure min. (bar) 6 (bar)	60	60	60	60

max. permissible closing pressures on flow-to-open P2 = 0.
 Observe restrictions by Pressure-temperature-ratings, refer to page 17.

¹⁾ Max. differential pressure drop bei Flow

Air supply pressure max. to actuator: 6 bar

Spring closes on air failure (Extended stem on air failure)

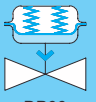
DN		10	15	20	25
Kvs-value	(m ³ /h)	2,7	4,2	6,4	8,6
max. differential press. ¹⁾	(bar)	2	2	2	2
Travel	(mm)	11	11	11	11
 DP33 400 cm ²	Spring range (bar)				
	Air supply pressure min. (bar) 2,3-3,7 4,5	(bar)	60	60	60

Spring opens on air failure (Retracted stem on air failure)

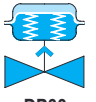
DN		10	15	20	25
Kvs-value	(m ³ /h)	2,7	4,2	6,4	8,6
max. differential press. ¹⁾	(bar)	2	2	2	2
Travel	(mm)	11	11	11	11
 DP33 400 cm ²	Air supply pressure min. (bar)				
	4,5 6	(bar)	60	60	60

max. permissible closing pressures on flow-to-open P2 = 0.

Observe restrictions by Pressure-temperature-ratings, refer to page 17.

¹⁾ Max. differential pressure drop bei Flow

Air supply pressure max. to actuator: 6 bar

Spring closes on air failure (Extended stem on air failure)

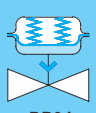
DN		32	40	50	65	80	100	125	150	
Kvs-value		(m³/h)	21,8	24,2	33	on request				
max. differential press. ¹⁾		(bar)	2	2	2					
Travel		(mm)	17	17	21					
 .DP34 800 cm²	Spring range (bar)	2,4-3,6	4,5	(bar)	60					
	Air supply pressure min. (bar)	4,5				(bar)				

Spring opens on air failure (Retracted stem on air failure)

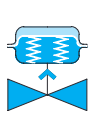
DN		32	40	50	65	80	100	125	150	
Kvs-value		(m³/h)	21,8	24,2	33	on request				
max. differential press. ¹⁾		(bar)	2	2	2					
Travel		(mm)	17	17	21					
 DP34 800 cm²	Air supply pressure min. (bar)	4,5	(bar)	65	65					
		6				(bar)	80	80	70	

max. permissible closing pressures on flow-to-open P2 = 0.
 Observe restrictions by Pressure-temperature-ratings, refer to page 17.

¹⁾ Max. differential pressure drop bei Flow

Air supply pressure max. to actuator: 6 bar

Pressure-temperature-ratings			Intermediate values for max. permissible operational pressures can be determined by linear interpolation of the given temperature / pressure chart.									
acc. to manufacturers standard			-10°C to 50°C	100°C	200°C	250°C	300°C	350°C	400°C			
1.0619+N	63	(bar)	63	55,1	45,9	42	38,1	35,4	34,1			
1.0619+N	100	(bar)	100	87,5	72,9	66,7	60,4	56,3	54,2			
1.0619+N	160	(bar)	160	140	116,7	106,7	96,7	90	86,7			
acc. to manufacturers standard			-10°C to 50°C	120°C	150°C	200°C	250°C	300°C	350°C	400°C	450°C	
1.0460	PN 63	(bar)	63	63	58	50	45	40	36	32	24	
1.0460	PN 100	(bar)	100	100	90	80	70	60	56	50	38	
1.0460	PN 160	(bar)	160	160	145	130	112	96	90	80	60	
acc. to manufacturers standard			-10°C to 250°C	300°C	350°C	400°C	450°C	500°C	520°C	530°C	540°C	550°C
1.5415	PN 63	(bar)	63	56	50	47	45	29	16	14	--	--
1.5415	PN 100	(bar)	100	87	78	74	70	45	27	22	--	--
1.5415	PN 160	(bar)	160	139	125	118	112	72	43	35	--	--
1.7335	PN 63	(bar)	63	63	61	58	56	47	32	25	20	15
1.7335	PN 100	(bar)	100	100	95	91	87	74	49	38	31	24
1.7335	PN 160	(bar)	160	160	153	146	139	118	79	62	46	35
1.7357	PN 63	(bar)	63	63	60	56,7	53,1	41,1	28,2	23,4	--	--
1.7357	PN 100	(bar)	100	100	95,2	90	84,2	65,2	44,7	37,1	--	--
1.7357	PN 160	(bar)	160	160	152,3	144	134,8	104,3	71,6	59,4	--	--

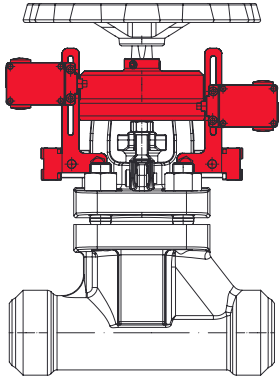

Limit switch, mechanic
(special limit switches on request)

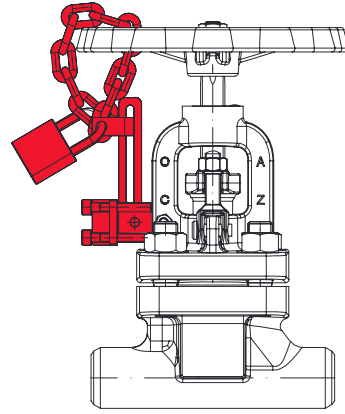

Tamper resistant
handwheel blocking

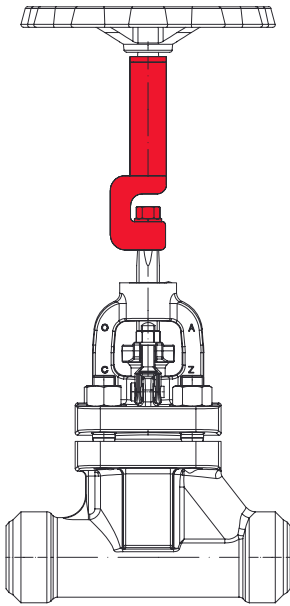

Stem extension
(please specify height in your order)

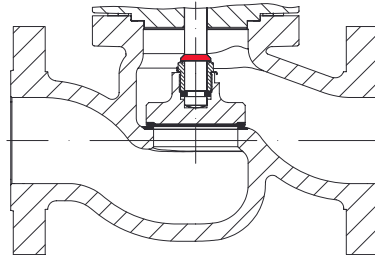

DN65-100: Back seat (when fully opened valve)
DN10-50: standard

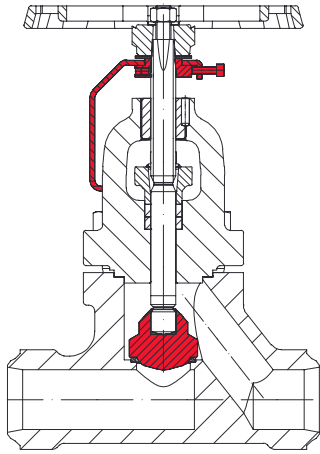

DN10-50: Regulating plug with position indicator and locking device
(for max. permissible ΔP refer to: Flow diagram)

DN65-100: on request

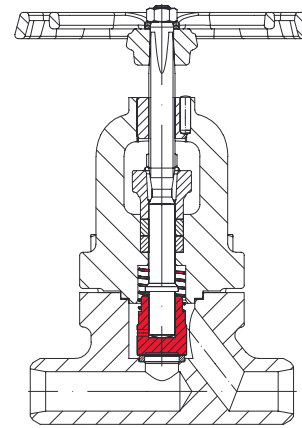

DN10-50: Screw down non-return plug with re-setting spring

DN65-100: on request

Set pressure 0,15 bar

Flow values (Kvs and Zeta) refer to data sheet „Check valves“.

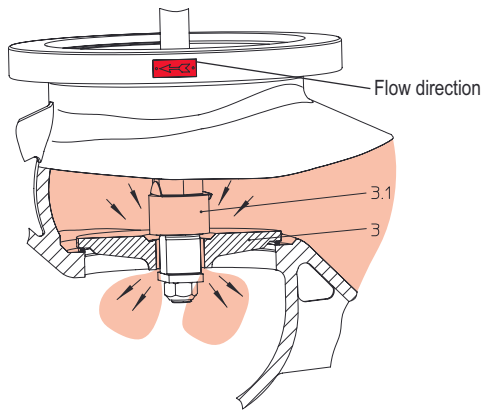

Valves with balancing plugs have to be installed with medium **flowing over the plug (3) as indicated by flow direction arrow on valve body.**

Working principles:

When the valve is closed, anticlockwise rotation of the hand wheel lifts the pilot plug (3.1) off the larger balancing plug (3).

This allows the medium to pass through the plug and equalizes the pressure of the medium under the plug (3). After the pressures have been equalized within the values stated in the table, the valve can be opened by turning the valve further with normal manual force.

Balancing plugs are fully effective only in closed systems.

The pressures of the medium on either side of the plug can not be equalized if the medium is discharged into open air.

A bypass line or some other arrangement is necessary if too much time is required for pressure equalization owing to the volume in the piping system.

Balancing plug

ARI-stop valves with differential pressures exceeding the following pressures, have to be fitted with pressure balancing plugs

DN	65	80	100	125	150
Gauge press. (ΔP) (bar)	110	70	44	on request	

Please indicate when ordering

- Figure-No.
- Nominal pressure
- Nominal diameter
- Special design / accessories

Example:

Figure 46.006; Nominal pressure PN63; Nominal diameter DN50; with regulating plug with position indicator and locking device.

Dimensions in mm
Weights in kg
1 bar Δ 10⁵ Pa Δ 0,1 MPa
Kvs in m³/h



Technology for the Future.
GERMAN QUALITY VALVES

ARI-Armaturen Albert Richter GmbH & Co. KG, D-33756 Schloß Holte-Stukenbrock,
Tel. +49 52 07 / 994-0, Telefax +49 52 07 / 994-158 or 159 Internet: <http://www.ari-armaturen.com> E-mail: info.vertrieb@ari-armaturen.com