

# Operating and installation instructions

In accordance with EC Directive 97/23/EC on Pressure Equipment

In accordance with EC Directive 2006/42/EC on Machinery

## Stop valve with gland seal

### STOBU<sup>®</sup> PN63-160

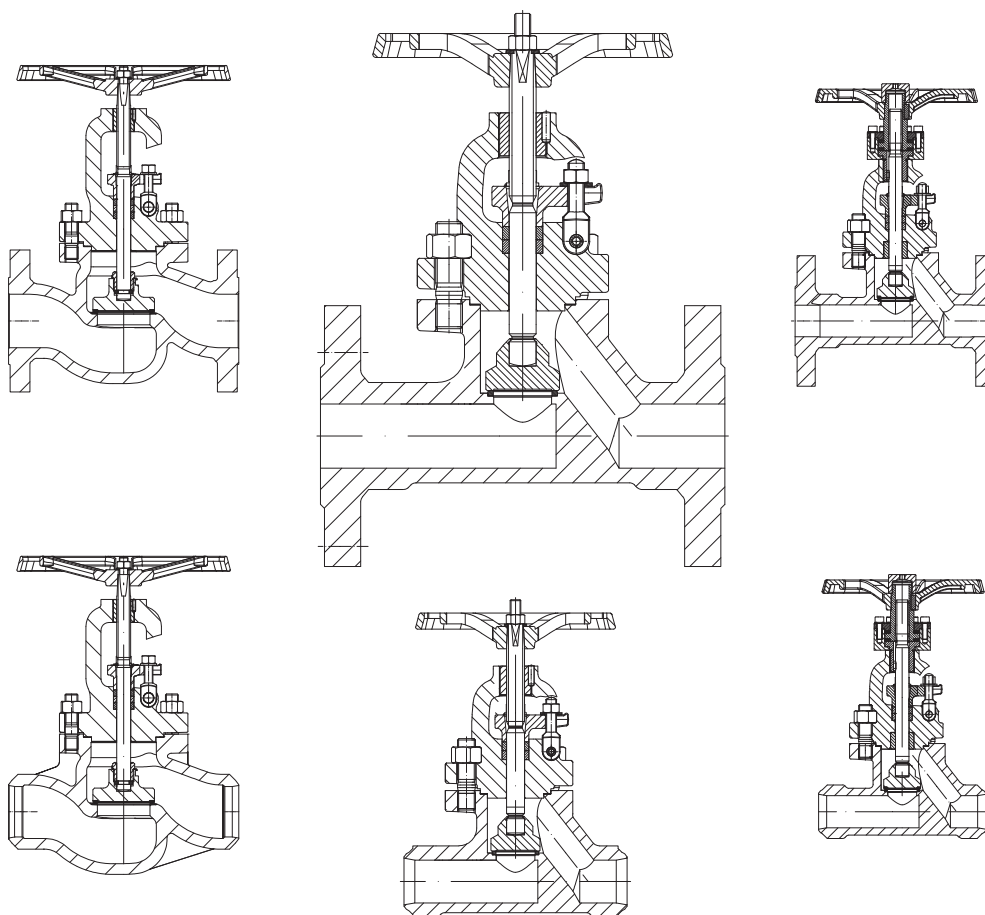

#### Contents

<b>1.0 General information on operating instructions</b> .....	<b>2-2</b>	5.4 Installing valves with limit switches .....	2-10
<b>2.0 Notes on possible dangers</b> .....	<b>2-2</b>	5.5 Conversion to lock bush B1 (Version: non-rising ..... handwheel)	2-10
2.1 Significance of symbols .....	2-2	5.6 Requirements at the place of installation .....	2-11
2.2 Explanatory notes on safety information .....	2-2	5.7 Installation instructions concerning actuators....	2-11
<b>3.0 Storage and transport</b> .....	<b>2-3</b>	<b>6.0 Putting the valve into operation</b> .....	<b>2-12</b>
<b>4.0 Description</b> .....	<b>2-3</b>	<b>7.0 Care and maintenance</b> .....	<b>2-13</b>
4.1 Scope of applications .....	2-3	<b>8.0 Troubleshooting</b> .....	<b>2-15</b>
4.2 Operating principles .....	2-4	<b>9.0 Troubleshooting table</b> .....	<b>2-15</b>
4.3 Diagram.....	2-5	<b>10.0 Dismantling the valve or the top part</b> ..	<b>2-17</b>
4.4 Technical data - remarks .....	2-7	<b>11.0 Warranty / Guarantee</b> .....	<b>2-17</b>
4.5 Marking .....	2-7	<b>12.0 Declaration of Conformity / Declaration of Incorporation</b> .....	<b>2-18</b>
<b>5.0 Installation</b> .....	<b>2-7</b>		
5.1 General notes on installation.....	2-7		
5.2 Installing valves with butt weld ends .....	2-9		
5.3 Installing valves with balancing plugs .....	2-9		

## 1.0 General information on operating instructions

These operating instructions provide information on mounting and maintaining the fittings. Please contact the supplier or the manufacturer in case of problems which cannot be solved by reference to the operating instructions.

They are binding on transport, storage, installation, start-up, operation, maintenance and repair.

You must read the operating instructions before commissioning the valve.

The notes and warnings must be observed and adhered to.

- Handling and all work must be carried out by expert personnel or all activities must be supervised and checked.

It is the owner's responsibility to define areas of responsibility and competence and to monitor the personnel.

- In addition, current regional safety requirements must be applied and observed when taking the fittings out of service as well as when maintaining and repairing them.

The manufacturer reserves the right to introduce technical modifications at any time.

These Operating Instructions comply with the requirements of EU Directives.

## 2.0 Notes on possible dangers

### 2.1 Significance of symbols

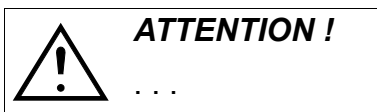

Warning of general danger.

### 2.2 Explanatory notes on safety information

In these Operating and Installation Instructions dangers, risks and items of safety information are highlighted to attract special attention.

Information marked with the above symbol and "**ATTENTION!**" describe practices, a failure to comply with which can result in serious injury or danger of death for users or third parties or in material damage to the system or the environment. It is vital to comply with these practices and to monitor compliance.

All other information not specifically emphasised such as transport, installation, operating and maintenance instructions as well as technical data (in the operating instructions, product documentation and on the device itself) must also be complied with to the fullest extent in order to avoid faults which in turn can cause serious injury to persons or damage to property.

### 3.0 Storage and transport



#### **ATTENTION !**

- *Protect against external force (like impact, vibration, etc.).*
- *Valve mountings such as actuators, handwheels, hoods must not be used to take external forces, e.g. they are not designed for use as climbing aids, or as connecting points for lifting gear.*
- *Suitable materials handling and lifting equipment should be used.*  
*See catalog sheet for weights.*

- At -20°C to +65°C.

- The paint is a base coat to protect against corrosion during transportation and storage. Do not damage paint protection.

### 4.0 Description

#### 4.1 Scope of applications

Valves are used for „shut-off and/or throttling of media“.



#### **ATTENTION !**

- *Refer to the data sheet for applications, limits on use and possibilities.*
- *Certain media require or preclude the use of special materials.*
- *The valves are designed for standard operating conditions. If conditions exceed these requirements, e.g. aggressive or abrasive media, the operator should state the higher requirements when ordering.*
- *You must state whether the valves are to be used in an explosive atmosphere (ATEX) at ordering.*  
***Special design!***

The information complies to the Pressure Equipment Directive 97/23/EC and Machine Guideline 2006/42 EC.

It is the responsibility of the machine planner to ensure compliance.

The special markings on the valve must be taken into account.

Refer to the catalogue sheet to see which materials are used in standard versions.

Please contact the supplier or the manufacturer if you have any questions.

## 4.2 Operating principles

The valve is closed by turning the hand wheel clockwise (valve plug/seating function).



**ATTENTION !**

- Do not use tools to increase the torque on the hand wheel.
- The necessary fire-protection measures depend on the medium and must be specified by the operator.

The valve stem is sealed by stuffing box.

Tighten the stuffing box if required.

The stopf valves are especially suitable for actuation by pneumatic or electrical actuators.



**ATTENTION !**

- The drive shaft is partially open and there is a **crushing hazard!**

**4.3 Diagram**

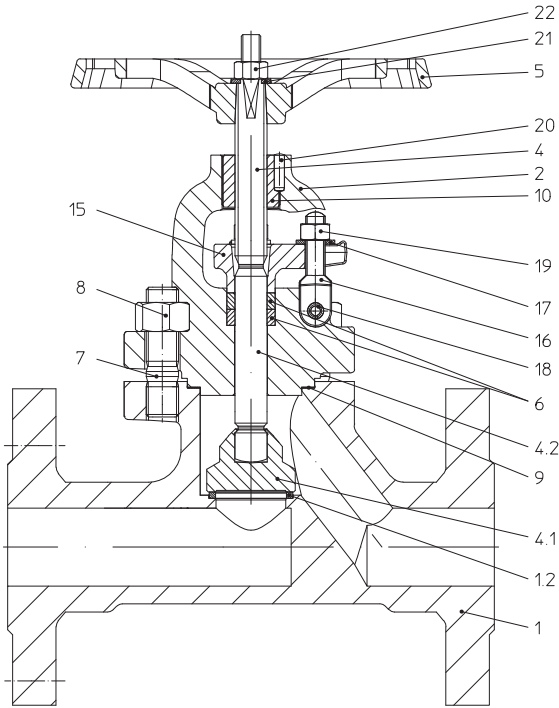

fig. 1: STOBU straight through DN10-50

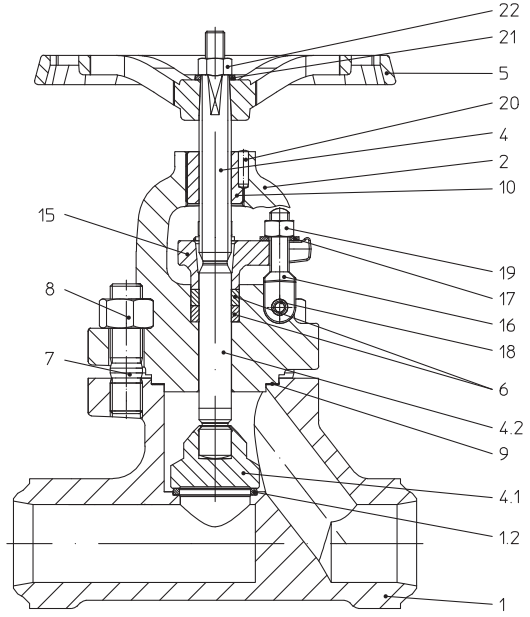

fig. 2: STOBU straight through with butt weld ends DN10-50

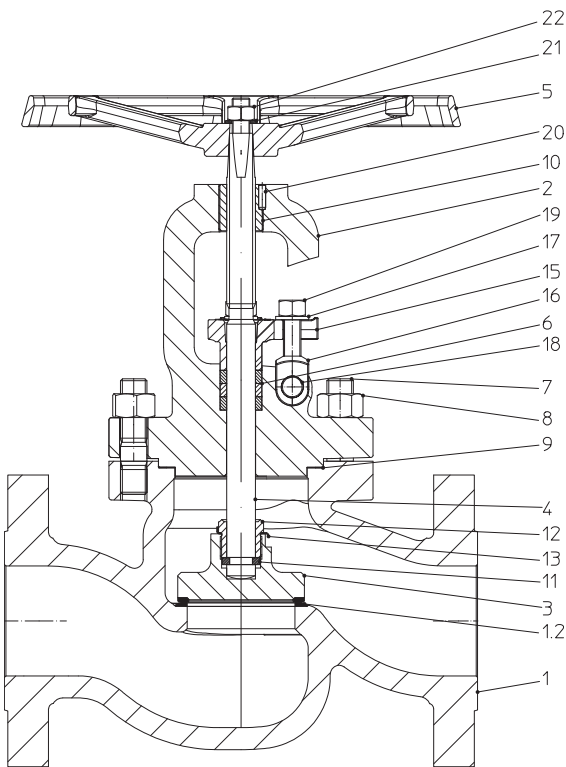

fig. 3: STOBU straight through DN65-100

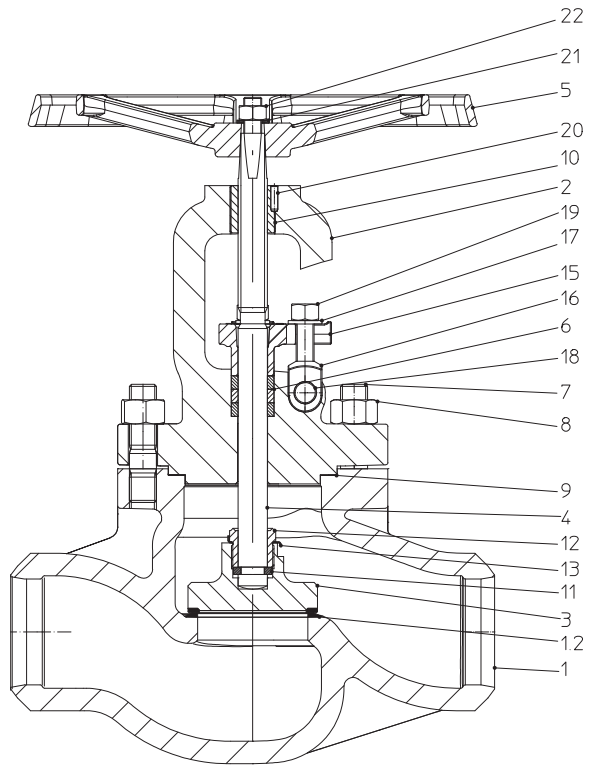

fig. 4: STOBU straight through with butt weld ends DN65-100

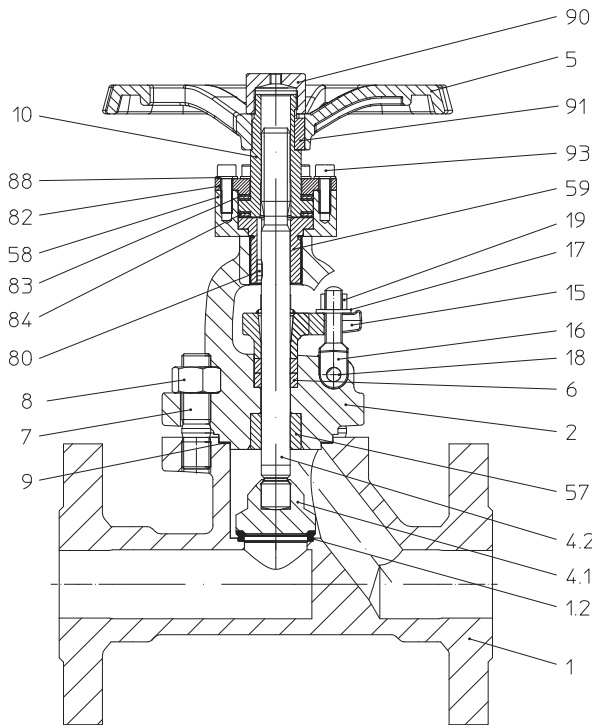

fig. 5: STOBU straight through DN10-50 with non-rising handwheel

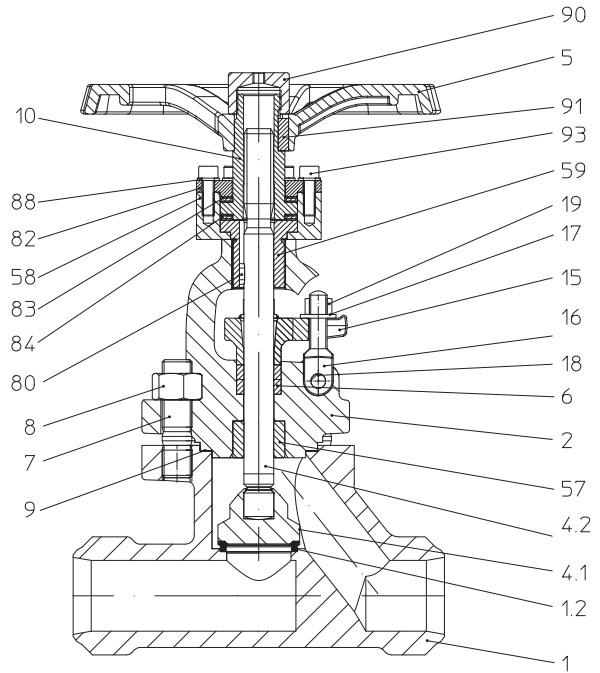

fig. 6: STOBU straight through with butt weld ends DN10-50 with non-rising handwheel

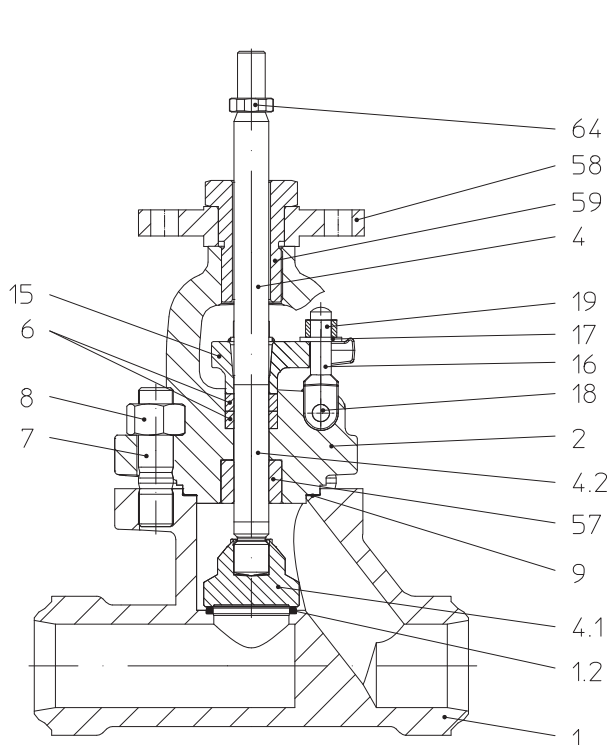

fig. 7: STOBU straight through DN10-50 with connection acc. to ISO 5210 group A

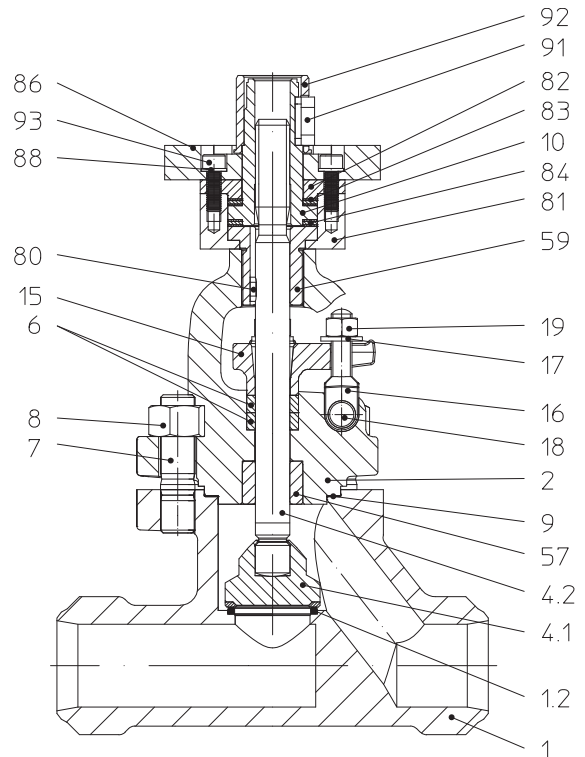

fig. 8: STOBU straight through DN10-50 with connection F10 acc. to ISO 5210 group (lock bush) B1

Refer to the data sheet for information about materials with designations and figure numbers.

## 4.4 Technical data - remarks

for

- Principal dimensions
- Pressure-temperature-ratings
- Valves with butt weld ends, etc. refer to datasheet.

## 4.5 Marking

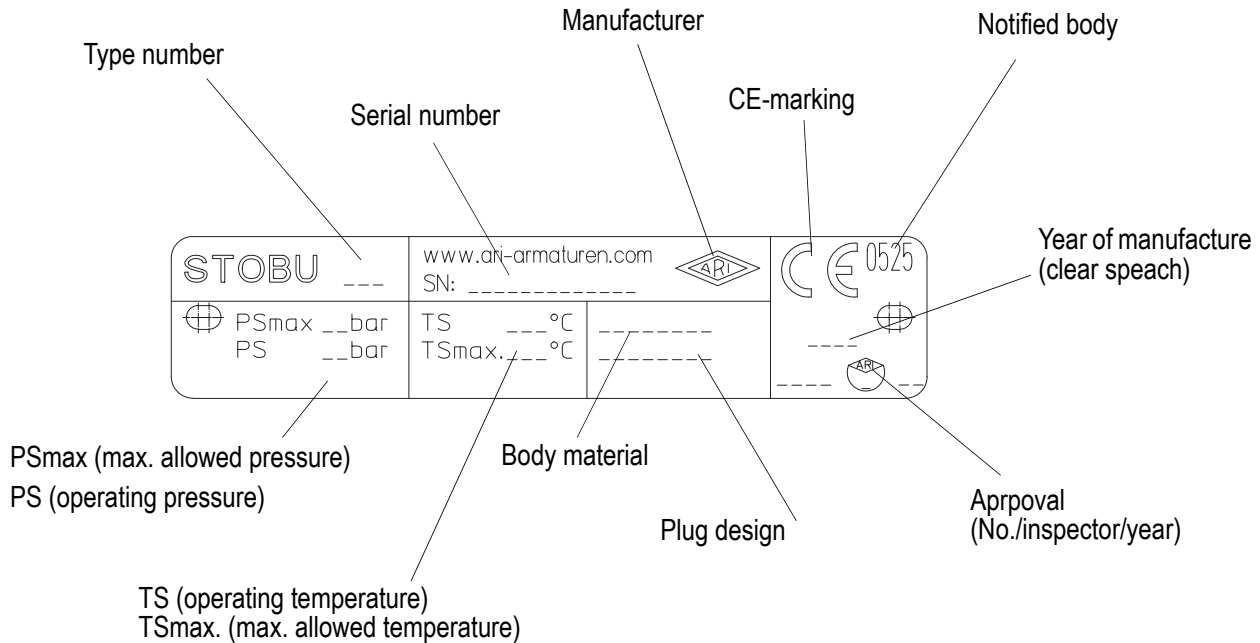

fig. 9

Address of manufacturer: refer to item 11.0 Warranty / Guarantee

According to the Pressure Equipment Directive table 6, annex II, valves without safety function are only allowed to bear the CE-marking DN32 onwards.

## 5.0 Installation

### 5.1 General notes on installation

The following points should be taken into account besides the general principles governing installation work:



#### **ATTENTION !**

- Remove flange covers if present.
- The interior of valve and pipeline must be free from foreign particles.
- Note installation position with reference to flow, see mark on valve.
- Steam line systems should be designed to prevent water accumulation.

- Lay pipelines so that damaging transverse, bending and torsional forces are avoided.
- Protect valves from dirt during construction work.
- Connection flanges must mate exactly.
- Connecting bolts for pipe flanges should be mounted preferably from the counter flange side (hexagon nuts from the valve side).  
At DN15-32: If valves should be mounted directly to valves, the upper flange connecting bolts should be preferably executed with studs and hexagon nuts on both sides.
- Valve mountings such as actuators, handwheels, hoods must not be used to take external forces, e.g. they are not designed for use as climbing aids, or as connecting points for lifting gear.
- With actuators mounted, you must disconnect the energy supply before starting work.
- You must only operate the unmounted valve while observing all the safety measures. **Crushing hazard!**
- Suitable materials handling and lifting equipment should be used.  
See data sheet for weights.
- Valves can be installed with the stem pointing in any direction, but the preferred stem position is vertical.
- Valves should be installed upside down only, if the medium being handled is clean.
- Keep the thread and shaft of the stem free from paint.
- Centre gaskets between the flanges.
- Lockable stop valves must be installed in such a way that the stem is vertical and the flow agent enters under the taper. If the valves are installed in pipelines in positions other than specified, they must be fitted with a closing spring.
- Design with loose plug with re-setting spring  
A plug damper should be used in critical applications, immediately downstream of pumps, compressors, etc., where severe turbulence and pulsating pressure surges may occur.  
Through the damper function of the loose plug, the negative influence of pressure shocks and high turbulences, are not transferred onto the valve.

- Planners / construction companies or operators are responsible for positioning and installing products.
- The valves are designed for application, not influenced from weather.
- For application outside or in adverse environments like corrosion-promoting conditions (sea water, chemical vapours, etc.), special constructions or protective measures are recommended.



## 5.2 Installing valves with butt weld ends

Please note that only qualified persons using appropriate equipment and working in accordance with technical rules are allowed to install fittings by welding.

The responsibility for this lies with the system owner.

Refer to the data sheet for information about the shape of the butt weld ends.

The valves must be welded in closed position.

## 5.3 Installing valves with balancing plugs



### **ATTENTION !**

*ARI stop valves must be equipped with pressure balancing plugs if the differential pressures listed in the table below are exceeded in the closed state.*

*Valves with pressure balancing plugs should be installed so that the pressure of the medium acts on the plug (pos. 3) and the stem is vertically upright.*

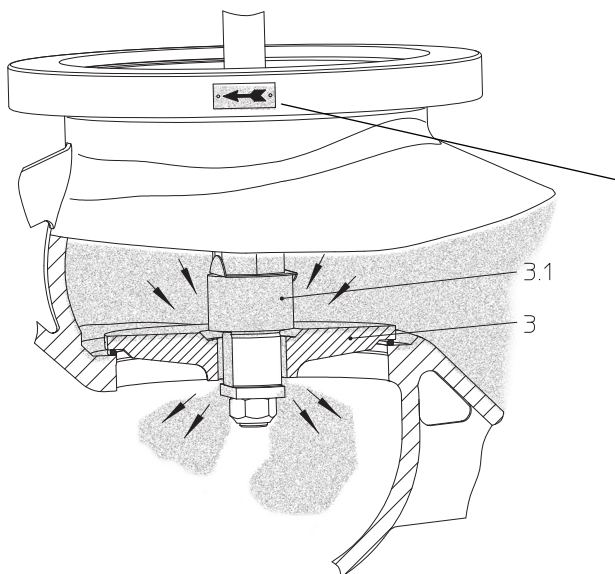

### **ATTENTION !**

**Note direction of flow.**

fig. 10

Valves with pressure balancing plugs have to be installed with medium flowing over the plug (pos. 3) as indicated by flow direction arrow on valve body.

### Working principles:

When the valve is closed, anticlockwise rotation of the hand wheel lifts the pilot plug (pos. 3.1) off the larger balancing plug (pos. 3). This allows the medium to pass through the plug and equalizes the pressure of the medium under the plug (pos. 3). After the pressures have been equalized within the values stated in the table below, the valve can be opened by turning the valve further.

Balancing plug	DN	65	80	100
Pressure difference	$\Delta P$	110 bar	70 bar	44 bar

- Pressure balancing plugs are fully effective only in closed line section.
- The pressures of the medium on either side of the plug cannot be equalized if the medium is discharged into “open air”.
- If adequate pressure equalisation cannot be achieved using a pressure balancing plug, other design solutions must be used instead (e.g. a bypass line).

## 5.4 Installing valves with limit switches

The valves with limit switches must be connected up as shown in the plans of the plant on the basis of their working principles.

## 5.5 Conversion to lock bush B1 (Version: non-rising handwheel)



### ATTENTION !

- The conversion must be carried out in compliance with all security measures.
- Countersunk screw (pos. 89) in the cover remains bolted to secure.
- F10 flange alignment acc. to the explosion graphic (fig. 11)!

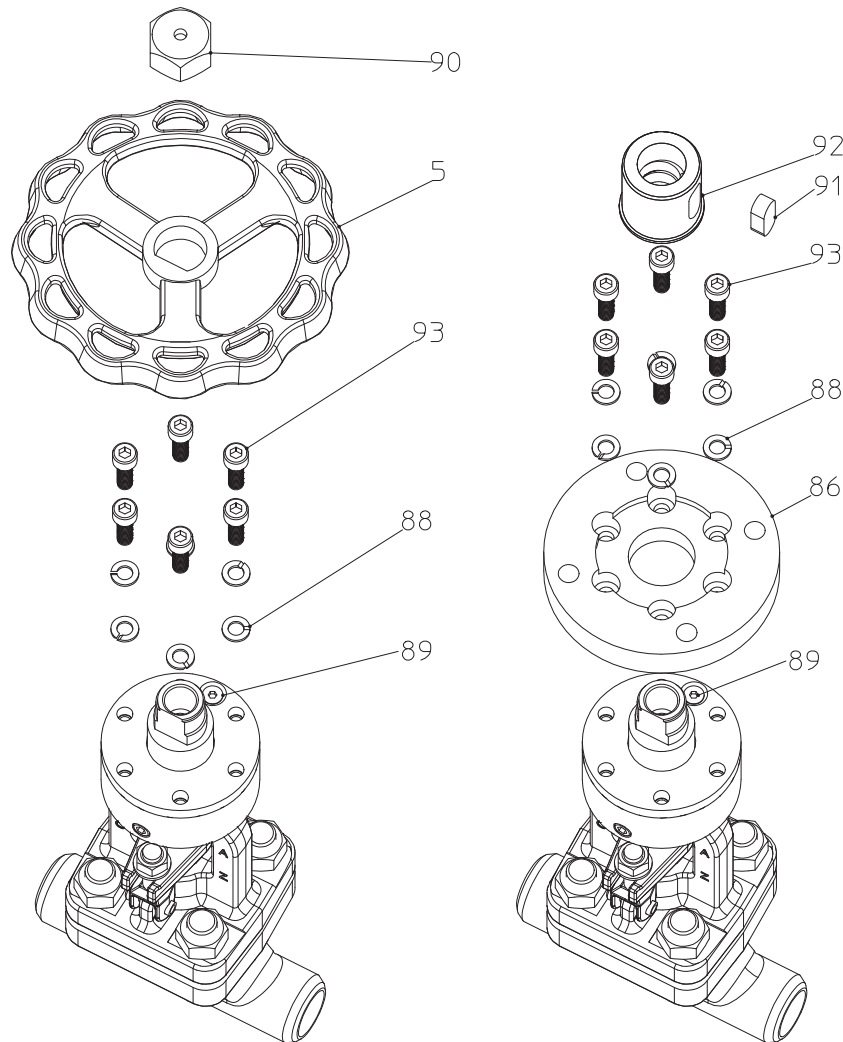

fig. 11: Conversion from version with handwheel to connection F10 acc. to ISO 5210 group (lock bush) B1

- Loosen guard cap (pos. 90)
- Remove handwheel (pos. 5)
- Loose 6 cylinder screws (pos. 93) and 6 spring rings (pos. 88)
- Align flange F10 (pos. 86) to the 6 holes (refer to fig. 11)
- Tighten the 6 spring rings (pos. 88) and 6 cylinder screws (pos. 93) crosswise
- Mount lock bush B1 (pos. 92)
- Mount parallel key (pos. 91)

## 5.6 Requirements at the place of installation

The place of installation should be easily accessible and provide ample space for maintenance and removing the actuator. Stop valves should be installed before and after the control valve to enable maintenance working without draining the piping system. The valve should preferably installed vertically with the actuator at the top. Inclined or horizontal installation without supports is permissible only with light actuators.

For this installation position, the two distance columns (or joke) have to be above each other in the vertical plane:

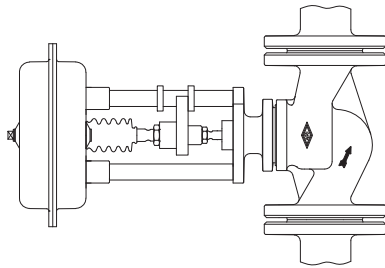

fig. 12: Pipeline vertically

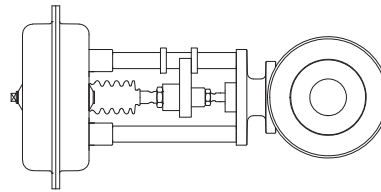

fig. 13: Pipeline horizontally

Permissible actuator weights for valves with unsupported horizontal stem is 25 kg.

The pipes must be lagged to protect the actuators from excessive heat. Sufficient space must be left for the maintenance of the stem packing.

## 5.7 Installation instructions concerning actuators

Normally, control valves are supplied complete with actuator fitted.

It is not permitted to mantle / dismantle actuators with valves operating and service conditions (temperature and pressure). The actuators must be assemble as describe in the operating instructions during conversion and maintenance.

During assembly work, the plug is not be turned on its seating at closing pressure.

When connecting the electrical actuators, you must comply with the specifications of the Low Voltage Directive. Connection (grounding) of electrical actuators must only be carried out by qualified personnel.

## 6.0 Putting the valve into operation



### **ATTENTION !**

- Before putting the valve into operation, check material, pressure, temperature and direction of flow.
- Regional safety instructions must be adhered to.
- Residues in piping and valves (dirt, weld beads, etc.) inevitably lead to leakage.
- Touching the valve when it is operating at high ( $> 50\text{ °C}$ ) or low ( $< 0\text{ °C}$ ) media temperatures can cause injury.  
Affix warning notice or protective insulation as appropriate.
- To prevent hydraulic jerks with a liquid medium, you must not slam valves closed. If necessary, chokes or dampers must be fitted.

*Before putting a new plant into operation or restarting a plant after repairs or modification, always make sure that:*

- All works has been completed.
- The valve is in the correct position for its function.
- Safety devices have been attached.

When putting the valve into operation, the tightness of the stuffing box seal (pos. 6) must be checked.

If the valve stem / stem unit (pos. 4) leaks, gradually tighten the stuffing box seal (pos. 6) evenly in increments by means of the hexagon nuts (pos. 19) until leaking stops (refer also to item 7.0 Care and maintenance).

## 7.0 Care and maintenance

Maintenance and maintenance-intervals have to be defined by the operator according to the requirements.

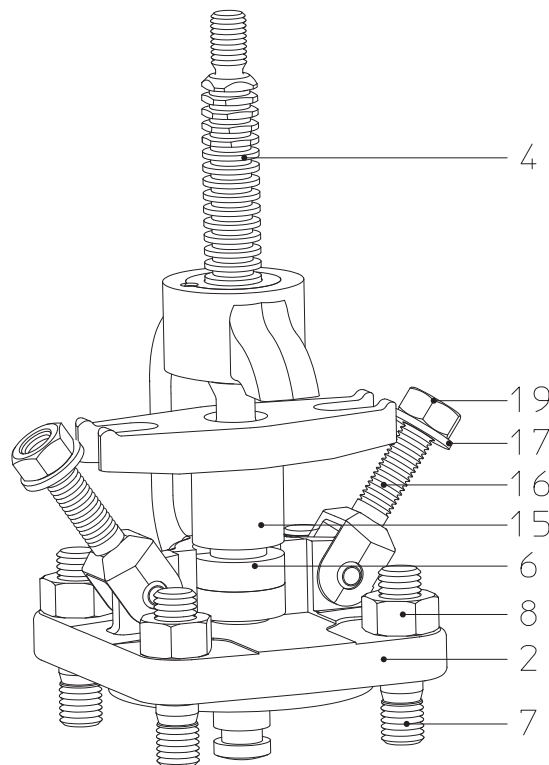

fig. 14: Pattern with hinged bolts

- Observe safety instructions!
- Keep the stem well greased!
- Lubricant: e.g. Klüberpaste HEL 46-450 (at valves for oxygen: Klüberalfa YV93-302)  
to order at: Klüber Lubrication München KG, Postfach 701047, D-81310 München  
or a lubricant which is suitable for the application.



**ATTENTION !**

*Pay attention, that the lubricant is suitable for the media.*

- If the valve stem / stem unit (pos. 4) leaks, gradually tighten the stuffing box seal (pos. 6) evenly in increments by means of the hex. nuts (pos. 19) until leaking stops.



**ATTENTION !**

- Refer to point 10.0 and 11.0 before dismantling the valve.
- Retighten the stuffing box packing if required and re-pack it in good time.
- For safety reasons we recommend that valves only be repacked when depressurised.
- When the valve is operated, there is a crushing hazard between the valve plug and the body.
- Only carry out maintenance work in the pipework when the valve has been secured from operation (the actuator has been disconnected from the mains supply and secured from reactivation.)

- Replace stuffing box packings only after the system has cooled down and the pressure in the plant has been relieved.

In the case of corrosive or aggressive mediums, drain and ventilate the valve before replacing the packing.

- Valve service life can be improved by leakage checks.

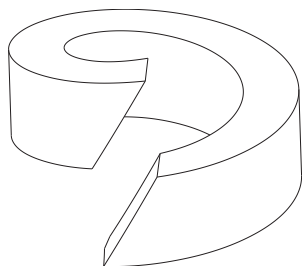

- When cutting the new packing (pos. 6) from the roll, make sure that the ends are cut with a slant (see fig. 15)

fig. 15: Split packing ring (pos. 6)

Mounting of the bonnet:

- Before reassembling the unit, remember that the bearing surface must be cleaned and a new gasket (pos. 9) must be inserted.
- Set the cover in place
- Tighten the hexagon nuts (hexagon screws for valves of cast iron) evenly crosswise.
- Tightening torque's for hexagon nuts / screws:

PN	DN	hexagon nuts / hexagon screws	Torque (Nm)
63 - 160	10 - 25	M 16	50 <sup>±2</sup>
	32 - 50	M 20	150 <sup>±3</sup>
	65	M 20	140 <sup>+20</sup>
	80	M 20	120 <sup>+20</sup>
	100	M 24	220 <sup>+20</sup>

## 8.0 Troubleshooting

In the event of malfunction or faulty operating performance check that the installation and adjustment work has been carried out and completed in accordance with these Operating Instructions.

	<p><b>ATTENTION !</b></p> <p>It is essential that the safety regulations are observed when identifying faults.</p>
---	--

If malfunctions cannot be eliminated with the help of the following table "9.0 Troubleshooting table", the supplier or manufacturer should be consulted.

## 9.0 Troubleshooting table

	<p><b>ATTENTION !</b></p> <p><b>- read point 10.0 and 11.0 prior to dismantling and repair work!</b></p> <p><b>- read point 6.0 before restarting the plant !</b></p>
---	---

Fault	Possible cause	Corrective measures
No flow	Valve closed.	Open valve.
	Flange covers not removed.	Remove flange covers.
Little flow	Valve not sufficiently open.	Open valve.
	Dirt sieve clogged.	Clean / replace sieve.
	Piping system clogged.	Check piping system.
Valve difficult to move or cannot be opened	Stem/ Stem unit dry (pos. 4; fig. 14)	Grease stem / Stem unit (pos. 4; fig. 14) (Lubricant: see page 13)
	Stuffing box too tight (pos. 6; fig. 1 - 8)	Slacken hex. nuts of stuffing box gland (pos. 15) slightly, but not sufficiently to cause leakage (fig. 1 - 8)
	Wrong direction of rotation	Turn in correct direction (anticlockwise to open valve).
Valve stem leaking	Stuffing box gland (pos. 15) slack (fig. 1 - 8).	Tighten stuffing box gland (pos. 15) until leakage stops. -Hex. nut (fig. 1 - 8).
		If necessary, renew packing in stuffing box seal (pos. 6). Observe warnings (fig. 14)!
Leakage across valve seat.	Valve not properly closed.	Pull hand wheel tight without tools.
	Seat (pos. 1.2) / plug (pos. 3 / 4.1) damaged by foreign particles. (fig. 1 - 8).	Replaced valve, consult supplier/manufacturer.
	Pressure difference too high.	Use a valve with balancing plug (see point 5.3).
	Medium contaminated (suspended solids).	Clean valve. Install dirt screen upstream of valve.
Leakage too high when valve is closed	Pneumatic actuator not completely vented; spring force not fully effective.	Vent actuator air chamber completely.
	Actuator not powerful enough.	Install more powerful actuator. Check service data.

Fault	Possible cause	Corrective measures
Valve with throttling plug + position indicator + locking device cannot be opened.	Locking device has been tightened.	Release locking device.
Rattling / banging of the plug design with „loose plug“	Nominal diameter of the valve in compliance to the flow rate is <u>to big</u>	Choose smaller nominal diameter Use a plug damper execution: see medium
	<ul style="list-style-type: none"> <li>- high flow turbulences;</li> <li>- the valve with loose plug is mounted directly by a centrifuged pump;</li> <li>- behind pressure reduction stations;</li> <li>- behind pipe elbows;</li> <li>- in compact plants;</li> <li>- expansion joints are missing;</li> <li>- the pump is not mounted on a damper;</li> <li>- there is no flow stabilizing pipe length;</li> <li>- there is no start-up bypass line</li> </ul>	Alter the system Use a plug damper execution: see medium
Flange broken between valve and piping.	Bolts tightened unevenly. Mating flanges not properly aligned.	Re-align piping and fit new valve!



## 10.0 Dismantling the valve or the top part



### **ATTENTION !**

*The following points must be observed:*

- *Pressureless pipe system.*
- *Medium must be cool.*
- *Plant must be drained.*
- *Purge piping systems in case of caustic, inflammable, aggressive or toxic media.*

## 11.0 Warranty / Guarantee

The extent and period of warranty cover are specified in the "Standard Terms and Conditions of Albert Richter GmbH & Co. KG" valid at the time of delivery or, by way of departure, in the contract of sale itself.

We guarantee freedom of faults in compliance with state-of-the-art technology and the confirmed application.

No warranty claims can be made for any damage caused as the result of incorrect handling or disregard of operating and installation instructions, datasheets and relevant regulations.

This warranty also does not cover any damage which occurs during operation under conditions deviating from those laid down by specifications or other agreements.

Justified complaints will be eliminated by repair carried out by us or by a specialist appointed by us.

No claims will be accepted beyond the scope of this warranty. The right to replacement delivery is excluded.

The warranty shall not cover maintenance work, installation of external parts, design modifications or natural wear.

Any damage incurred during transport should not be reported to us but *rather* to the competent cargo-handling depot, the railway company or carrier company immediately or else claims for replacements from these companies will be invalidated.



**Technology for the Future.**

**GERMAN QUALITY VALVES**

ARI-Armaturen Albert Richter GmbH & Co. KG, D-33756 Schloß Holte-Stukenbrock

Telephone (+49 5207) 994-0 Telefax (+49 5207) 994-158 or 159

Internet: <http://www.ari-armaturen.com> E-mail: [info.vertrieb@ari-armaturen.com](mailto:info.vertrieb@ari-armaturen.com)

## 12.0 Declaration of Conformity / Declaration of Incorporation

### Declaration of Conformity according to Directive 97/23/EC on Pressure Equipment

We,

**ARI-Armaturen Albert Richter GmbH & Co. KG,  
Mergelheide 56-60, D-33756 Schloß Holte-Stukenbrock**

hereby declare that the products listed below comply with the following requirements.

Description of valve series:

Stop valve with gland seal ARI-STOBU®						
Type	Nominal pressure	Nominal diameter	Fluid group	Module	Certificate-No.:	Applied standards
005	PN 63-160	DN 32 - 100	I	H	--	DIN EN 12516-2 AD 2000 leaflet A4 (1.0619+N, 1.0460, 1.5415, 1.7335, 1.7557)
006	PN 63-160	DN 32 - 100	I	H		
<b>Note:</b> According to the above mentioned Directive 97/23/EC on Pressure Equipment (article 3, paragraph 3) products in DN 10-25 are executed and classified acc. to „Sound engineering practice“. These products are not covered to the requirements of the Pressure Equipment directive and need not to carry a CE mark.						

Name and address of the notified licensing and monitoring agency:

**Lloyd's Register Quality Assurance GmbH  
Am Sandtorkai 41, D-20457 Hamburg**

Number of the named agency

**0525**

### Translated Declaration of Incorporation for partly completed machinery according to EC Directive 2006/42/EC on Machinery

for the products mentioned above:

As the manufacturer, ARI-Armaturen GmbH & Co. KG hereby declares that the products mentioned above comply with the following basic requirements of the **Machinery Directive (2006/42/EC)**.

Annex I, Clauses 1.1.2, 1.1.3, 1.1.5, 1.2.1, 1.3.1, 1.3.2, 1.3.4, 1.3.7, 1.3.9, 1.5.1, 1.5.3, 1.5.4, 1.5.5, 1.5.6, 1.5.7, 1.5.15, 1.6.1, 1.7.1, 1.7.2, 1.7.3, 1.7.4

The following harmonised standards were used:

DIN EN ISO 12100: 03/2011

ARI products are specified for assembly with electrical, pneumatic and hydraulic actuators. Commissioning must not be carried out until it has been ensured that the entire machine into which the ARI products are to be installed complies with the stipulations of EC Directive 2006/42/EC.

The manufacturer undertakes to submit in electronic form the relevant documentation of the partly completed machinery in response to a duly reasoned request by the competent national authorities. The special technical documentation associated with the machine has been drawn up in accordance with Annex VII Part B.

Authorised representative for the technical documentation: Heinrich Kramig

Schloß Holte-Stukenbrock, 28.02.2013

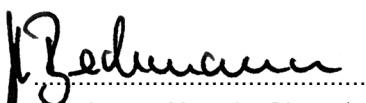
  
(Brechmann, Managing Director)

The declaration certifies compliance with the stated Directive; it does not, however, represent any assurance of features in the sense of product liability legislation. The safety information in the supplied product documentation must be observed. This declaration is invalidated if modifications that the manufacturer did not authorize are made to the device or if the safety information is not complied with.