



IOM - Instructions for installation,
operation and maintenance of:

Forged Strainers
according to BS/ANSI

[SAP]



“TERMOVENT” SC
Temerin

Republic of Serbia

Table of Contents

1. General safety information's	3
2. Product description	3
3. Storage and handling.....	4
4. Installation and start-up.....	5
5. Usage and maintenance	6
6. Service and repair	7
7. Possible malfunctions and solutions	8
8. Guarantee	8

1. General safety information's

- Instructions for installation, start-up and maintenance during the period of exploitation of strainers manufactured in the "TERMOVENT" SC should be used as a manual intended for all personnel directly or indirectly involved in dealing with the aforementioned goods.
- These instructions are only related to Strainers.
- Operators in charge of installation, operation and maintenance of strainers during the period of use, should be fully trained for the correct / optimal performance of these tasks.
- Information about temperatures and allowable working pressures shown in our technical data sheets are according to ASME B16.34, Table 2. Under no circumstances should the valves be operated at conditions outside these tables.
- Because strainers in working conditions have hot parts (body and cover) and may cause burns, the operator has an obligation to undertake all necessary precautions to avoid such by using protective facilities.
- Before the service or reinstallation of the strainers, the plant or installation should be taken out of operation (pressure 0 bar, temperature of strainers should be the same temperature as the environment).
- These products are recyclable. No ecological hazard is anticipated with the disposal of these products providing due care is taken.

2. Product description

- The main purpose of the Strainers is to collect solid particles and impurities from fluids in the pipeline.
- If anything is unclear at the time of installation, start-up or during use, and not covered in these instructions, the departments of the "TERMOVENT" SC should be contacted directly in order to obtain the required support.

All Strainers manufactured in "TERMOVENT" SC are marked with following marks:

- Identification of manufacturer ("TERMOVENT" SC logo);
- Nominal diameter of strainer NPS (inch) or DN(mm);
- Nominal pressure Class rating (#);
- Material designation of body and cover;
- Body and cover melt identification/heat number;
- Trim identification- material grade for net;
- Unique serial number;
- Arrow mark for allowable direction of flow;
- Date of manufacture (month and year) ;
- Maximum allowable pressure at maximal temperature according to ANSI B16.34
- Pipe ends flanges and body/bonnet flanges grooved for ring joints and the rings to be used with them shall be marked with corresponding ring number;
- Other marks in accordance with customer request or product standard.

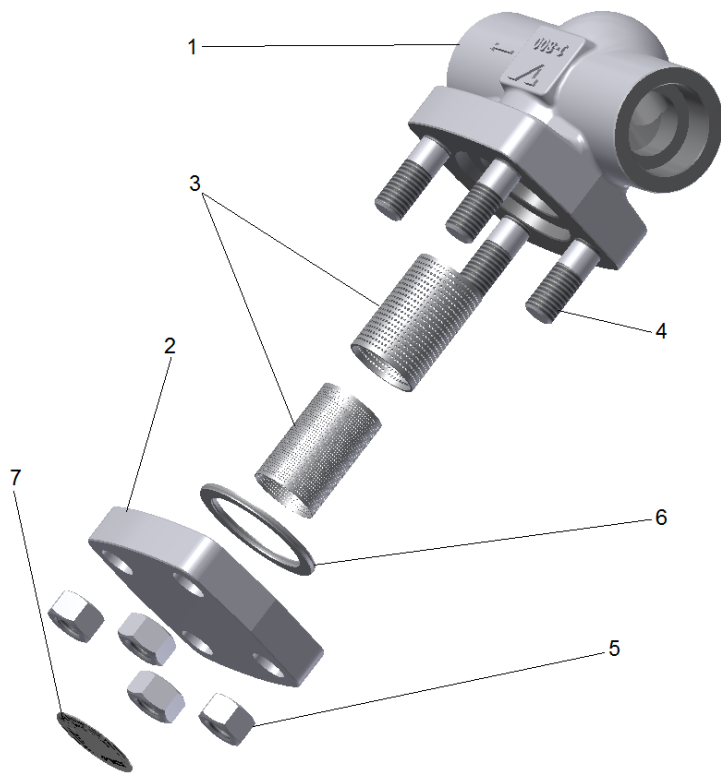

Fig 1.Parts

Table 1.

Pos.	Part Name	Quantity	Spare Parts
1	Body	1	
2	Cover	1	
3	Net	1	
4	Stud bolts	4	
5	Nuts	4	
6	Gasket	1	YES
7	Nameplate	1	

3. Storage and handling

General information

Strainers are delivered with protective covers on their ends. During storage period protective covers shall not be removed.

3.1 Recommended storage facilities

- The strainers have to be stored in closed, clean, dry and ventilated storage facilities.
- Storage conditions shall be: ambient temperature in the range +10°C to +35°C and the humidity up to 85%
- Store the strainers in their original shipped packing.
- Strainers should be taken out of crates or removed from the covering of a pallet just before installation.

3.2 Storage inspection

- Periodical inspection should be performed on all stored strainers. At the minimum, all strainers should be inspected every 3-4 months for dirt, moisture or any other type of contamination. If any is found the strainer is to be thoroughly cleaned and dried.
- Slight external rusting may occur on strainer. This will have no effect on their performance.
- If strainers are stored for more than 6 months we recommended following:
 - Preservation of inner surfaces, inner parts, flange facing, butt welding ends and threads shall be repeated every 6 months with appropriate corrosion preventive coating
 - Re-tighten diametrically opposite all the bolts as per factory specifications to overcome possible bolt relaxation during long-term storage (Fig.3)

3.3. Handling requirements

- For strainer handling and/or lifting the lifting equipment must be sized and selected while taking into account the strainer weight indicated at packing list. Lifting and handling must be made only by qualified personnel. Caution must be taken during the handling to avoid that this equipment passes over the workers. For strainers handling or lifting the lifting equipment must be sized and selected while taking or over any other place where a possible fall could cause damage.

WARNING !!!

- | |
|---|
| <ul style="list-style-type: none">➤ You must not lift strainers using the connection flange holes➤ You must not remove the protection covers from the strainer connection ends |
|---|

4. Installation and start-up

- After the removal of the protection covers it is necessary to thoroughly clean inside the strainer with compressed air.
- Do not disassemble or modify a strainer in any way prior to installation. This will void the factory warranty if it occurs.
- When installing strainers with flanged ends it is necessary to take into consideration the selection of adequate bolt material and the appropriate type of gasket depending on the type of working fluid, pressure, temperature, and the type of flange facing. It is necessary to install gaskets strictly in accordance with instructions given from the manufacturer of the gaskets.
- Strainers with welding ends should be welded onto the pipeline by an expert and with appropriate WPS. After welding, if necessary, local normalization should be performed and the inside of the pipeline should be cleaned to remove possible welding remains.
- At the moment of installation the influence of the load of the pipeline on the strainer should be reduced. The same also applies for temperature oscillation, hydraulic impact and similar. The strainer should not be used as a support for a pipeline.
- It is important to take care about the flow direction at the time of installation. The flow direction is indicated with the arrow mark casted or imprinted on the body of the strainer.
- Mounting is allowed in any position, but it is recommended that the cover is positioned down Fig. 2, for easier cleaning and preventing the retention of impurities in the central part body. You must pay attention on direction of flow.

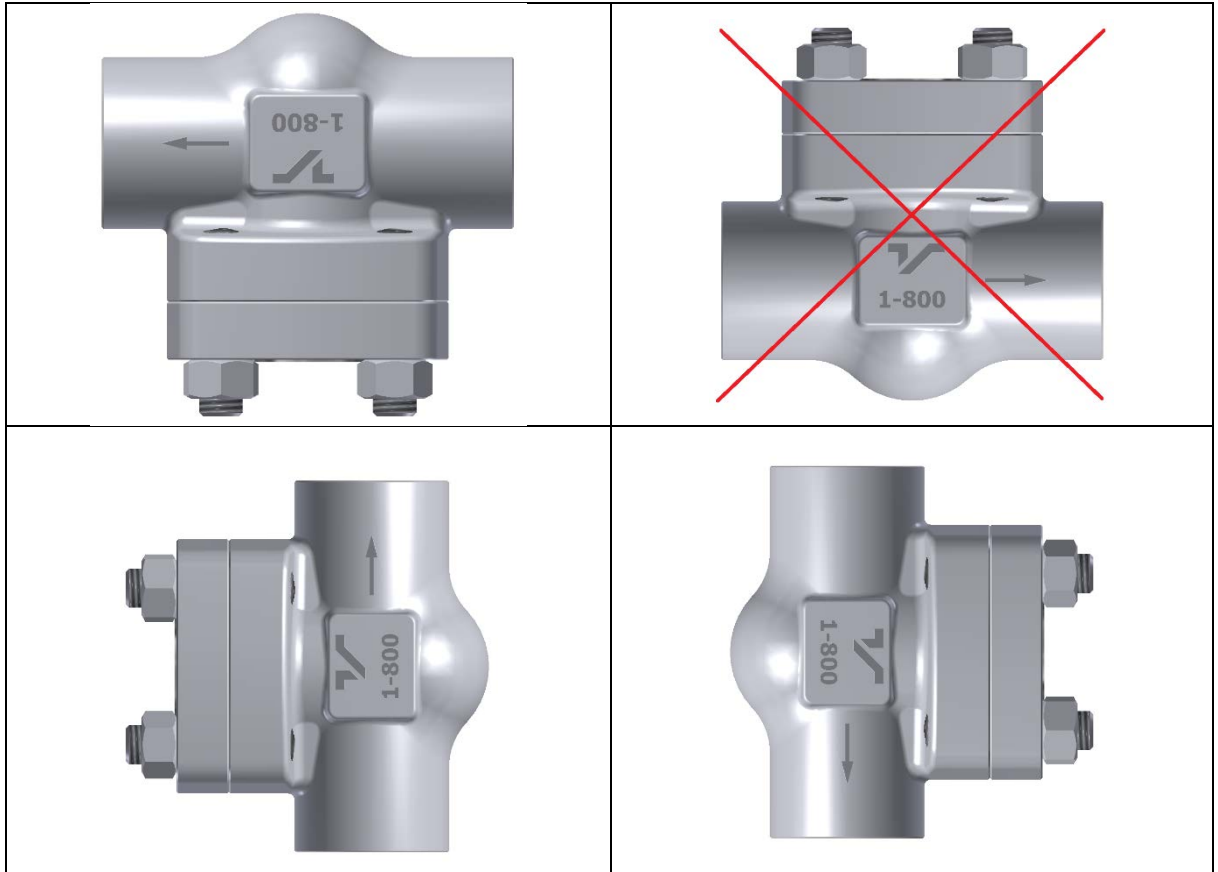

Fig. 2 Recommended mounting position

WARNING!!!

- Do not disassemble or modify a strainer in any way prior to installation. This will void the factory warranty if it occurs.
- You must not lift the strainer using the connection flange holes at the moment of the installation on the pipeline – you should use lifting straps.
- Before installation the impurities should be removed from the pipeline or from the appliance;
- Remove protecting covers from the strainer ends, degrease and clean the inside of the strainer, and in case of a flanged connection, carefully clean the sealing surfaces;
- Confirm that the marks on the strainers correspond to the projected parameters of the plant (e.g. size, pressure, material etc.) and installation is according to allowable flow direction;
- Confirm that the velocity of the fluid at the place of the installation is in range of the recommended velocity;
- At the moment of testing of a pipeline or an installed appliance strainer; take care about the predicted maximal differential pressure.

5. Usage and maintenance

- It is convention during usage of the strainers that all minor defects, if operating conditions allow, should be repaired on the spot. If not, the strainer should be dismantled from the site in order to perform a full repair. If the strainer is severely damaged it should be replaced with a new one. Such repairs protect strainers against further deterioration, being permanently out of work and being the cause of severe accidents in the plant.
- In case of leakage through gaskets between strainer connection flanges or between the cover and body, it is necessary to make replacements of the gaskets as soon as possible to prevent damage of the sealing surfaces due to erosion.

WARNING!!!

- If, when a strainer is overhauled, a decrease of wall thickness of more than 30% is detected at any of the ports (due to erosion) the strainer should stop being used;
- Any time when a strainer is dismantled or reinstalled the gaskets should be replaced with new ones with the appropriate quality;
- Strainer maintenance and manipulation during use should be done only by experts and persons well trained for such purpose;
- At the moment of installation of the plant sudden and extreme change of pressure and temperature should be avoided;

6. Service and repair

- Only authorized persons should perform service and repair with appropriate tools and, if it is possible, using original spare parts. Personal protection should be applied in accordance with valid regulations and legalizations.
- Attention should always be paid to the reliability of the strainers and parameters of the working implementation / plant, and only materials which can successfully replace those originally installed should be used.
- For highly reliable strainers (strainers which work with high temperatures, high pressures or with dangerous fluids) any service, repair or replacement should be done professionally and responsibly in accordance with valid regulations for safe working conditions at the plant.
- Before the service or reinstallation of the strainers, the plant or installation should be taken out of operation (pressure 0 bar, temperature of strainers should be the same temperature as the environment).
- Every Strainer serviced or repaired should be subject to all necessary tests usually performed for a newly produced strainer.
- Bolts for connection between body and cover should be tightened evenly and crosswise applying appropriate torque.
- For high temperature and high pressure applications after 24 hours of operation, all nuts shall be re-tighten diametricly opposite up to design stresses. This action compensate any relaxation or creep. Periodic inspection is recommended, thereafter.
- Bearing in mind the responsibility of the equipment in the eventual replacement of materials / parts, installed materials must be at least the same or better quality than to the originally.
- Possible torques for tightening are listed in Table 2 and the selection of torque depends on the material grade of bolts and nuts used, as well as the quality of the gasket.

Table 2.

Nominal bolt diameter	Material of bolts: B7	Material of bolts: B16	Material of bolts: B8
	Torque [Nm]	Torque [Nm]	Torque [Nm]
M10	55	55	20
M12	90	90	30
M14	140	140	45
M16	215	215	65
M18	270	275	85
M20	410	415	125

7. Possible malfunctions and solutions

During the period of usage of the installed strainer malfunctions may occur. Only experts in the premises of the user should undertake repairs. The most common cause of malfunctions and how to overcome such situations is listed in Table 3.

Table 3.

Failure	Possible cause	Troubleshooting
Absence of flow	Protection covers are not removed	Remove protection covers from connection ends
	Very dirty filter (net).	Clean out net (Pos.3) or replace net with new one.
Reduced or aggravated flow	Dirty filter (net).	Clean out net (Pos.3) or replace net with new one.
Leakage on gasket	Nuts (Pos.5) are not tightened	Evenly tighten the nuts (Pos.5)
	Gasket (Pos.6) is damaged	Disassemble cover (Pos.2) and replace gasket (Pos.6) with new one

8. Guarantee

- The Guarantee issued by “TERMOVENT” SC confirms the safe working of its products under conditions when these products are properly installed in accordance with the instructions in the documentation given to the customer, and usage is in accordance with approved technical conditions and working parameters.
 - The Guarantee is void if inappropriate parts from other manufacturers are implemented, if the user changes construction, or if there is any decline in function or malfunction due to natural wear and tear.

Guarantee conditions:

- The Guarantee is valid for defective parts or defective products, when any such defect is confirmed by an expert engaged by the customer and approved by experts from our company. In such a situation “TERMOVENT” SC will replace the defective part(s) or defective product(s).
- Replacement of defective part(s) or defective product(s) with new one(s) should be done only by an expert engaged by the customer upon approval or by instruction of our experts and in accordance with the instructions for installation.
- The Guarantee period is not valid if installation and manipulation of the strainers isn't in accordance with these instructions. The Guarantee period for all replaced parts or product(s) starts from the moment the replacement(s) is/are done.

The Guarantee is valid only if the strainers are handled, stored, installed, used and maintained in full accordance to the Instructions and recommendation listed in this Document.

WARNING!!!

- After detection of mistakes “Termovent” SC should be informed immediately.
- Claims must be made in writing.