



C 06 K-10-HA



C 06 M

Filter-regulator »multifix-mini«

Size 0

C 05

G 1/8

C 06

G 1/4

5 µm

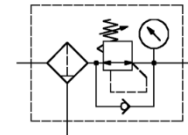

Characteristics

Type	C 05	C 06
Port	G 1/8	G 1/4
Pressure gauge port	G 1/8	
Type of construction	Diaphragm pressure regulator / self-relieving design / Centrifugal filter /	
Input pressure p ₁ max.	single (independent) component: 16 bar Multi-element unit: 12 bar	
Input pressure p ₁ min.	1,5 bar	
Control range p ₂	0,1-3 bar / 0,5-10 bar 0,2-6 bar / 0,5-16 bar (option)	
Mounting position	vertical, drain valve at bottom	
Mounting typet	Bracket on the top, -hole circle Ø30,5 ;	
Medium temperature	max.60°C (other temperatur-	
Ambient temperature	max.60°C ranges on request)	
Filter rating	5 µm	
Bowl capacity	max. 16 cm ³ condensate	
Construction of drain valves	semi automatic, - standard equipment (HA4) - manual and fully autom. on request	
Weight [g]	280 / 360 incl. pressure gauger	

Description

- Modular principle
- Simple block mounting with other devices
Connector sets (**KP 05**) are required, creating a unit assembly system
- Pressure setting can be locked by pushing the knob down
- Pressure entry in direction of marking (▶)
- Pressure gauge included
- Bowl guard (option) can be retrofitted without tools (plastic bowl KS 11 F required)

Accessories

Designation	Order.-No.
Nut M 30x1,5	R 11-55
Mounting bracket with nut R 33-55	MV 30
Joiner set	KP 05
Polycarbonate bowl	640/1
Metal bowl	640/11
Filter-element 5 µm	611.6.905
Plastic bowl / fully automatic drain valve	KS 11 F-A
Metal bowl / semi-automatic drain valve	641/11-HA
Metal bowl / fully automatic drain valve	640/11-A

Variants

Order-No: = basic+addition

Basic		
C 05-*	C 06 *	
Port G 1/8	Port G 1/4	
Variants	Addition	
Control range 10 bar / plastic bowl / semi-automatic drain valve	* K-10-HA	
Control range 3 bar / plastic bowl / semi-automatic drain valve	* K-3-HA	
Control range 10 bar / plastic bowl / fully-automatic drain valve	* K-10-A	
Control range 3 bar / plastic bowl / fully-automatic drain valve	* K-3-A	
Control range 10 bar / metal bowl / manual drain valve	* M	
Control range 10 bar / metal bowl / fully automatic drain valve	* M-A	
Ordering example: Fiter-regulator »multifix-mini« / port size G 1/4 / control range 10 bar / plastic bowl / semi-automatic drain valve	Basic C 06	Addition K-10-HA

Standards and directives

97/23/EU (DGRL)	Extent of validity: §3, passage3 No marking (according to attachment II, Diagram2 true for § 3, passage 3)
ISO 4414	General rules and safety requirements for pneumatic fluid power systems and components used on machinery
RoHS	No validity

Dimensions [mm]

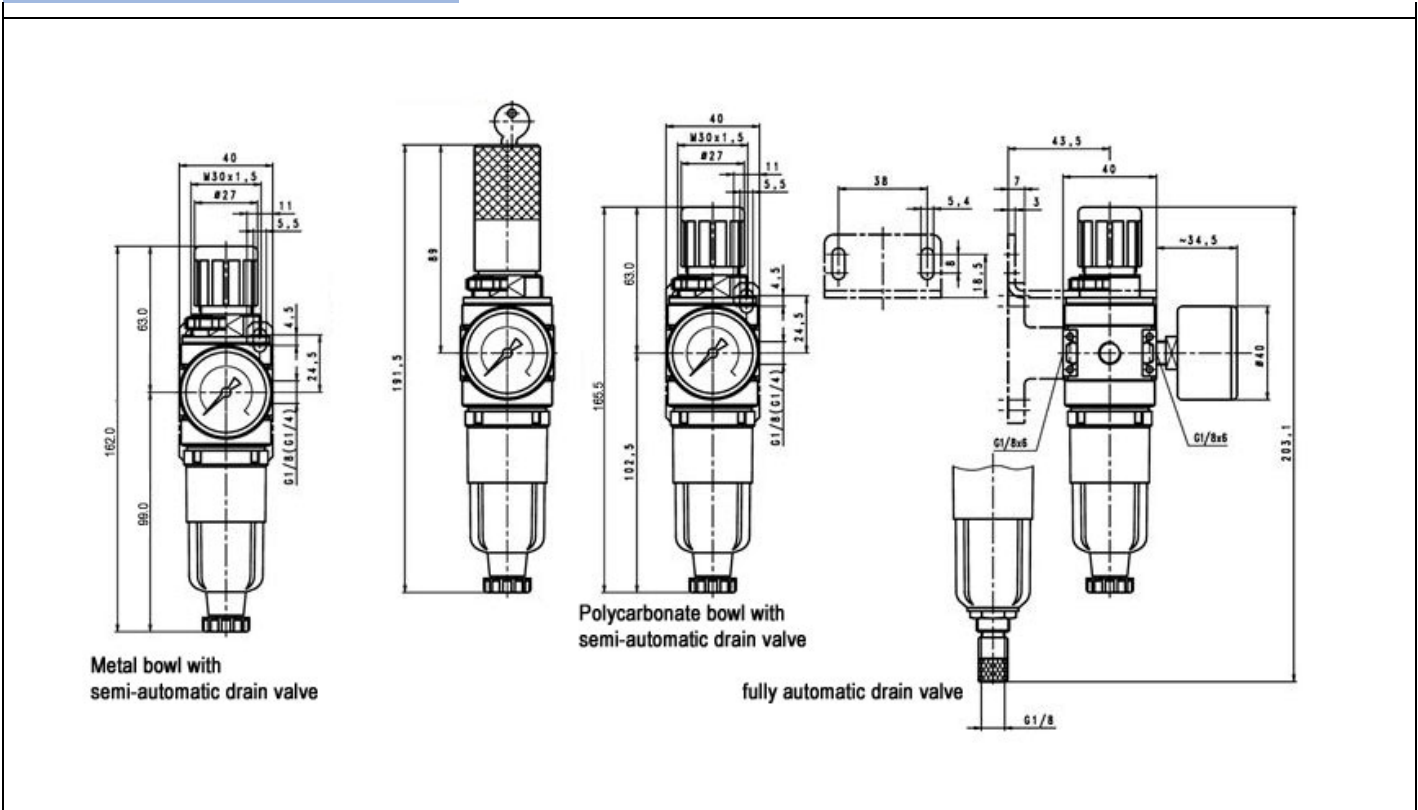

Flow rates

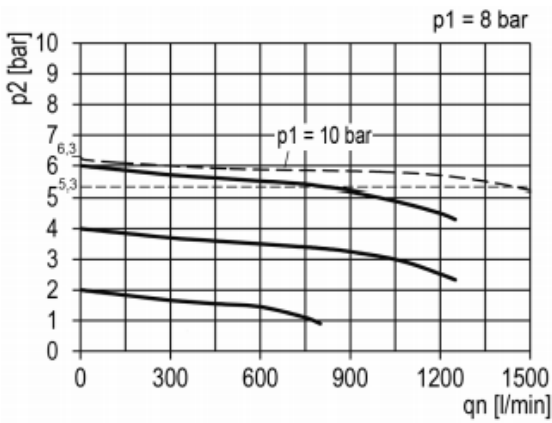

Hysteresis

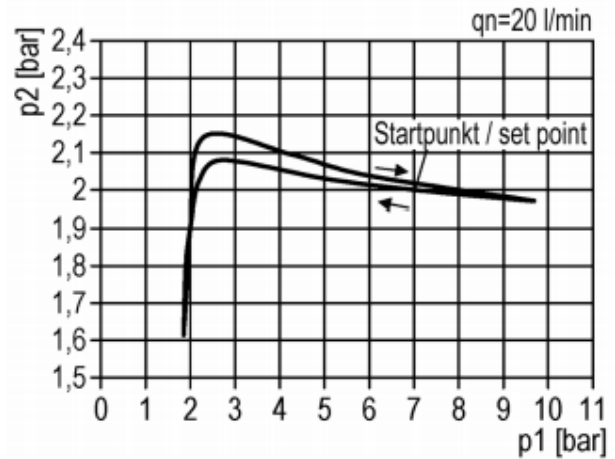

Material

Component	Material
Head piece (body)	Z 410
Spring bonnet	POM-brass
Diaphragm	→ NBR-brass
Control spring	St. galvanised
Valve cone	→ NBR-brass
counter pressure spring	Stainless steel
O-ring 30x2	→ NBR
Spring bonnet lockable	POM-Al
Key cylinder	Brass
Filter-element 5 µm	Cellpor
Condensate bowl	Polycarbonate
Baffle/cone-channell	POM / PA6

Main spare parts

Designation	Order-No.
Set of wearing parts	22.1805.4
Filter-element 5 µm	611.6.905