

# S38

## S38 111 016.148 PN16 DN50-DN300 Stainless steel gate valve flange

### STAINLESS STEEL GATE VALVE FLANGED PN16 SHORT PATTERN (3202-1 F4)

Stainless steel gate valve TRIM10 flanged PN16 full bore for water distribution, gas oil, steam, petrochemical, petroleum industry and gas.

Short pattern 3202-1 F4 with flexible one piece wedge.

Graphite packing for stem and gasket bonnet in stainless steel+graphite.

Compatible with explosive atmosphere, ATEX Zone 1&21 and Zone 2&22.



**Certificate**  
**3.1**



PED 2014/68/UE



**Size :** DN50 to DN300  
**Connection :** Flanges RF PN16  
**Min Temperature :** -29°C  
**Max Temperature :** +538°C (+300°C with corrosive fluid)  
**Max Pressure :** 16 Bars  
**Specifications :** Rising non rotating stem  
Bolted bonnet and packing  
Full bore

**Materials :** Stainless Steel ASTM A351 CF8M

# S38

## S38 111 016.148 PN16 DN50-DN300 Stainless steel gate valve flange

### STAINLESS STEEL GATE VALVE FLANGED PN16 SHORT PATTERN (3202-1 F4)

#### SPECIFICATIONS :

- Full bore
- Rising, non-rotating stem
- Fixed non rising handwheel
- Flexible one piece wedge
- Flanges R.F. PN16
- Stainless steel body
- Bolted bonnet and gland pack
- TRIM 10 standard AISI 316
- ATEX

#### USE :

- Water distribution, gas oil, steam, petrochemical, petroleum industry, gas
- Min and max Temperature Ts : - 29°C to + 538°C (300°C with corrosive fluid)
- Max Pressure Ps : 16 bars
- **Do not use with scraper**
- Tighten the gland packing in service

#### FLOW COEFFICIENT Kvs :

DN ( mm )	50	65	80	100	125	150	200	250	300
Kvs	265	423	614	1124	1807	2690	4947	7727	11546

#### TORQUE VALUE ( in Nm without safety coefficient ) :

DN	50	65	80	100	125	150	200	250	300
Torque (Nm)	37	68	85	107	165	180	265	410	540

#### NUMBER OF CYCLES TO CLOSE OR OPEN THE VALVE :

DN	50	65	80	100	125	150	200	250	300
Number of cycles	15	20	18	23	28	33	38	45	55

#### PRESSURE / TEMPERATURE RELATION :

( According to BS EN 12516-1 for A351 CF8M )

Pressure ( Bar )	15.7	15.7	15.2	13.3	12.2	11.3	10.5	10	9.6	9.4	9.3	9.2	9.1	9.1	8.6	8	7.6
Temperature (°C)	-29	38	50	100	150	200	250	300	350	375	400	425	450	475	500	525	538

#### RANGE :

- Stainless steel gate valve with flanges R.F. PN16 Ref. 148 From DN 50 to DN 300

# S38

## S38 111 016.148 PN16 DN50-DN300

### Stainless steel gate valve flange

#### STAINLESS STEEL GATE VALVE FLANGED PN16 SHORT PATTERN (3202-1 F4)

#### MATERIALS :

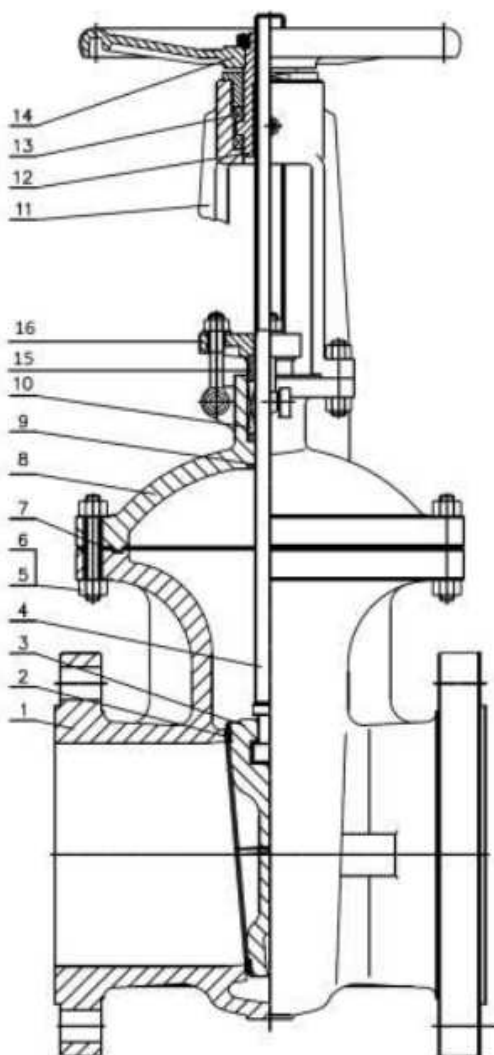

#### Repairability :



\*Gaskets kit (Items 7 and 10)

DN (mm)	Ref.
50	9802300
65	9802301
80	9802302
100	9802303
125	9802303a
150	9802304
200	9802305
250	9802306
300	9802307

(\* : included in gaskets kit)

Item	Designation	Materials
1	Body	ASTM A351 CF8M
2	Seat	ASTM A351 CF8M
3	Wedge	ASTM A351 CF8M
4	Stem	ASTM A182 F316
5	Stud bolt	ASTM A193 Gr B8
6	Nut	ASTM A194 Gr 8
7*	Bonnet gasket	AISI 316 + graphite
8	Bonnet	ASTM A351 CF8M
9	Back seat bushing	Coating 13Cr
10*	Packing	Graphite
11	Yoke	ASTM A351 CF8M
12	Stem nut	Aluminium + Bronze
13	Ring	E51100
14	Handwheel	Cast iron
15	Packing gland	ASTM A351 CF8M
16	Gland flange	ASTM A351 CF8M

# S38

## S38 111 016.148 PN16 DN50-DN300

### Stainless steel gate valve flange

STAINLESS STEEL GATE VALVE FLANGED PN16 SHORT PATTERN (3202-1 F4)

SIZE ( in mm ) :

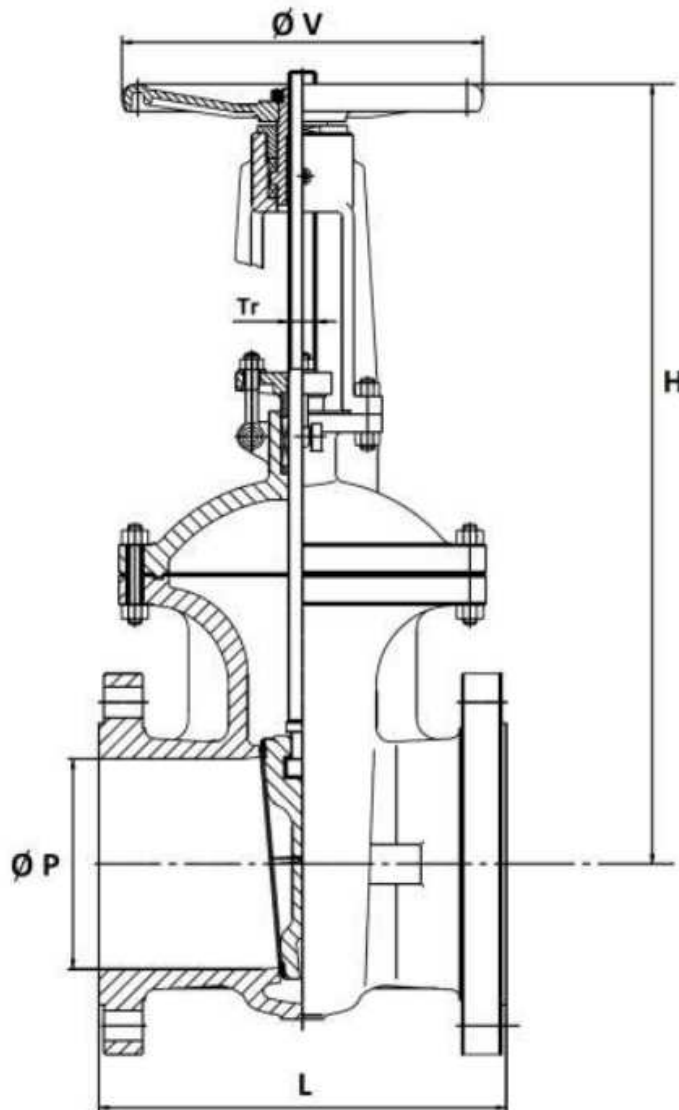

DN ( mm )	50	65	80	100	125	150	200	250	300
Ø P	50	63	78	100	125	150	203	254	300
L	150	170	180	190	200	210	230	250	270
H (opened)	356	463	459	544	685	757	988	1166	1400
H (closed)	299	385	372	437	548	595	768	900	1075
Ø V	240	240	240	280	350	350	400	400	500
Stem threading Tr	Tr18x4LH	Tr20x4LH	Tr22x5LH	Tr26x5LH	Tr28x5LH	Tr28x5LH	Tr32x6LH	Tr36x6LH	Tr38x6LH
Weig. (Kg)	15	23	27	35	56	67	106	163	220
Ref.	148050	148065	148080	148100	148125	148150	148200	148250	148300

# S38

## S38 111 016.148 PN16 DN50-DN300 Stainless steel gate valve flange

STAINLESS STEEL GATE VALVE FLANGED PN16 SHORT PATTERN (3202-1 F4)

FLANGES SIZE ( in mm ) :

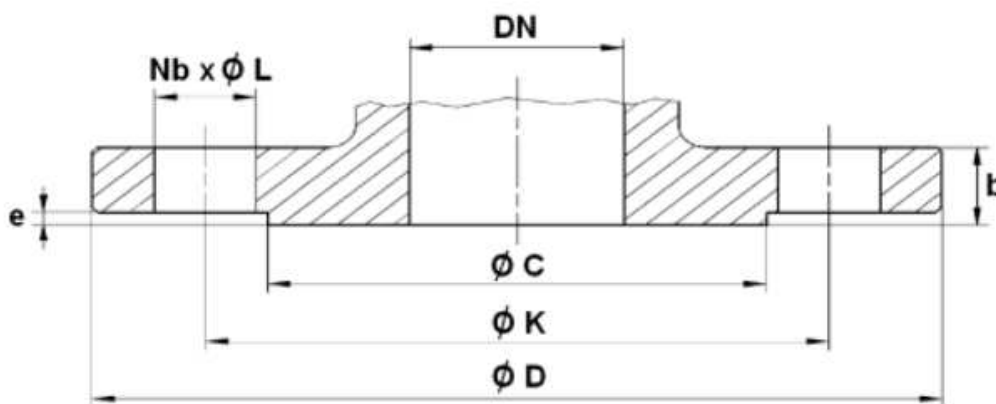

DN ( mm )	50	65	80	100	125	150	200	250	300
Ø C	102	122	138	158	188	212	268	320	378
Ø D	165	185	200	220	250	285	340	405	460
Ø K	125	145	160	180	210	240	295	355	410
Nb x Ø L	4 x 18	8 x 18	8 x 18	8 x 18	8 x 18	8 x 22	12 x 22	12 x 26	12 x 26
b	18	18	20	20	22	22	24	26	28
e	3	3	3	3	3	3	3	3	4

# S38

## S38 111 016.148 PN16 DN50-DN300 Stainless steel gate valve flange

STAINLESS STEEL GATE VALVE FLANGED PN16 SHORT PATTERN (3202-1 F4)

### STANDARDS :

- Manufacturer certified ISO 9001 : 2015 and ISO 14001 : 2015
- DIRECTIVE 2014/68/EU : For liquids and gas of Group 1
  - DN50 : Risk Category I, CE 0036 marking
  - DN65-200 : Risk Category II, CE 0036 marking
  - DN250-300 : Risk Category III, CE 0036 marking
- Certificate 3.1 on request
- Designing according to EN 1984 and EN 12516-1
- Pressure Tests according to EN 122661-1, Rate D
- Length according to EN 558 series 14 (DIN 3202-1, series F4)
- Flanges R.F. according to EN 1092-1 PN16
- ATEX Group II Category 2 G/2D Zone 1 & 21 Zone 2 & 22 ( optional marking ) according to directive 2014/34/EU