

D71 118 016.240 – FILTR PŘÍRUBOVÝ

FLANGED STAINLESS STEEL STRAINER PN16



ISO 9001:2008

BUREAU VERITAS
Certification



Size: DN 15 to DN 200
Ends: ISO PN16 Flanges R.F.
Min Temperature: - 20°C
Max Temperature: + 200°C
Max Pressure: 16 Bars
Specifications: Removable stainless steel filter
Bolted bonnet with draining cap

Materials: Stainless steel

FLANGED STAINLESS STEEL STRAINER PN16

SPECIFICATIONS :

- Removable stainless steel filter
- ISO PN16 Flanges R.F.
- Horizontal or vertical position with descendant fluid (respect the flow direction indicated by the arrow)
- Mesh 8/10° mm (800 μ) up to DN 50 , 10/10° mm from DN 65 to 80 and 30/10° over
- Bolted bonnet with draining cap threaded BSP

USE :

- For Chemical and pharmaceutical industries, petrochemical industries, hydraulic installation, compressed air
- Min Temperature Ts : - 20°C
- Max Temperature Ts : + 200°C
- Max Pressure Ps : 16 bars (see graph)

PRESSURE / TEMPERATURE GRAPH (STEAM EXCLUDED) :

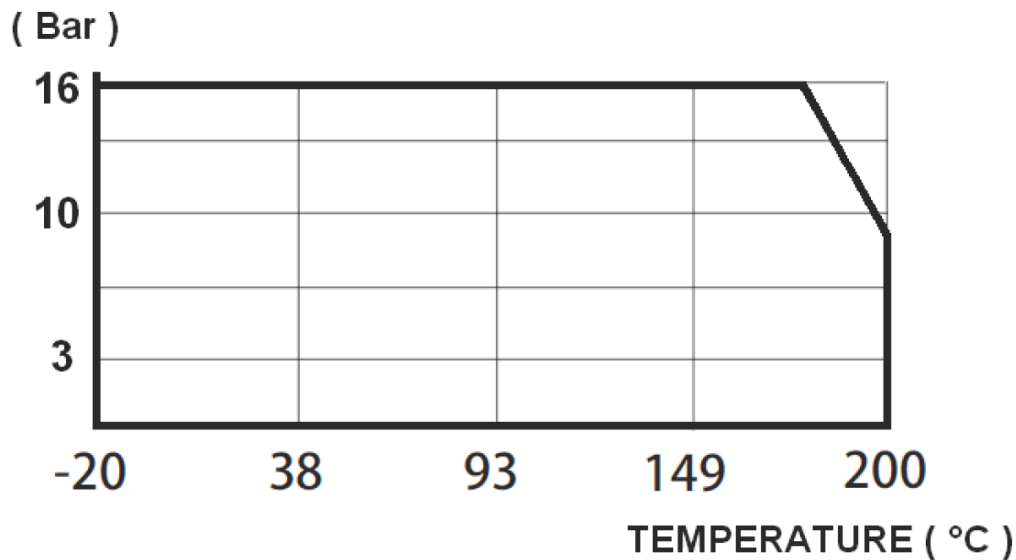

FLOW COEFFICIENT Kvs (M3 / h) :

DN	15	20	25	32	40	50	65	80	100	125	150	200
Kvs (m3/h)	2.59	6.05	12.1	17.3	27.7	56.2	85.5	138.4	259.5	415.1	605.4	882.3

RANGE :

- ISO PN16 Flanges R.F. from DN 15 to DN 200 **Ref.240**

FLANGED STAINLESS STEEL STRAINER PN16

HEAD LOSS GRAPH :

DN 15 - 40

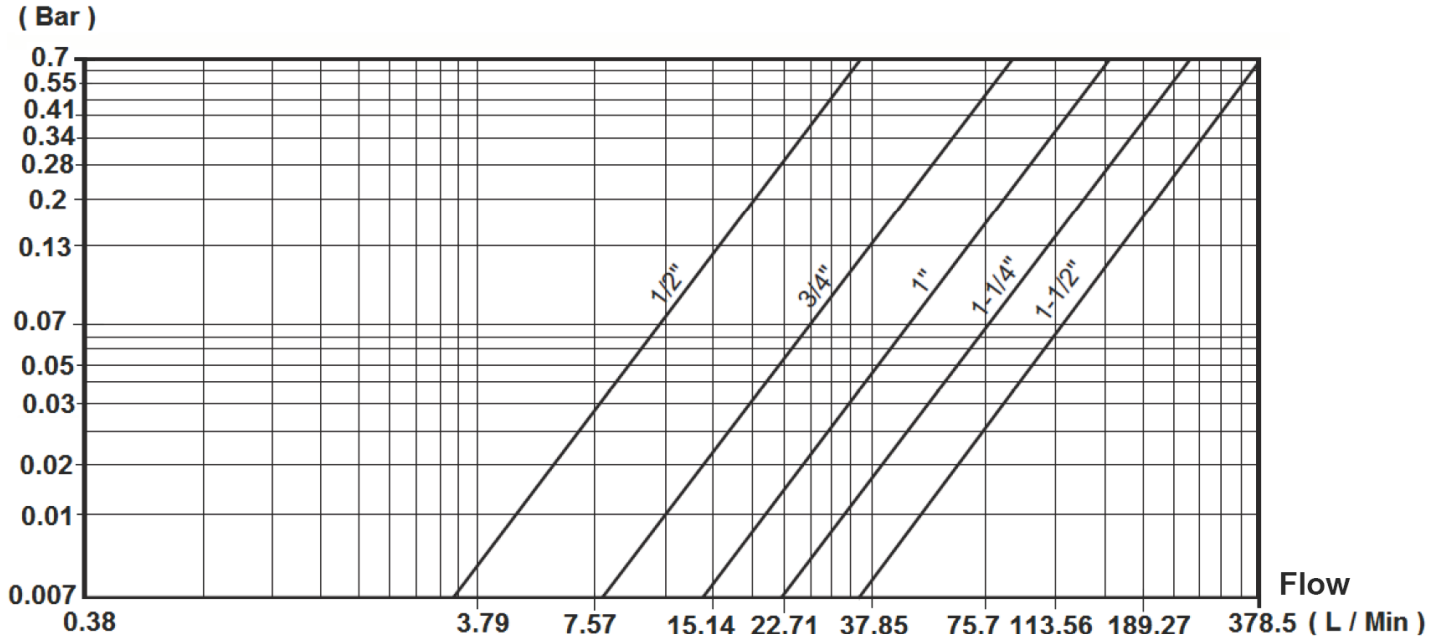

DN 50 - 200

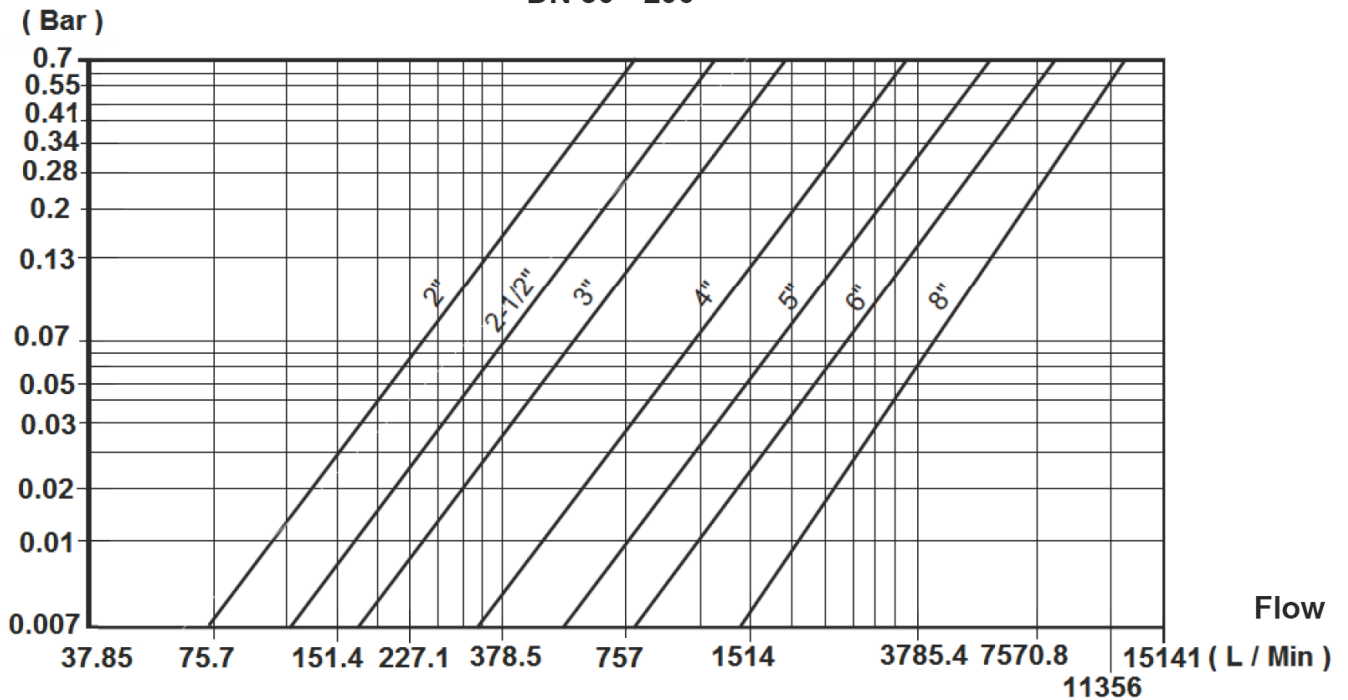

FLANGED STAINLESS STEEL STRAINER PN16

MATERIALS :

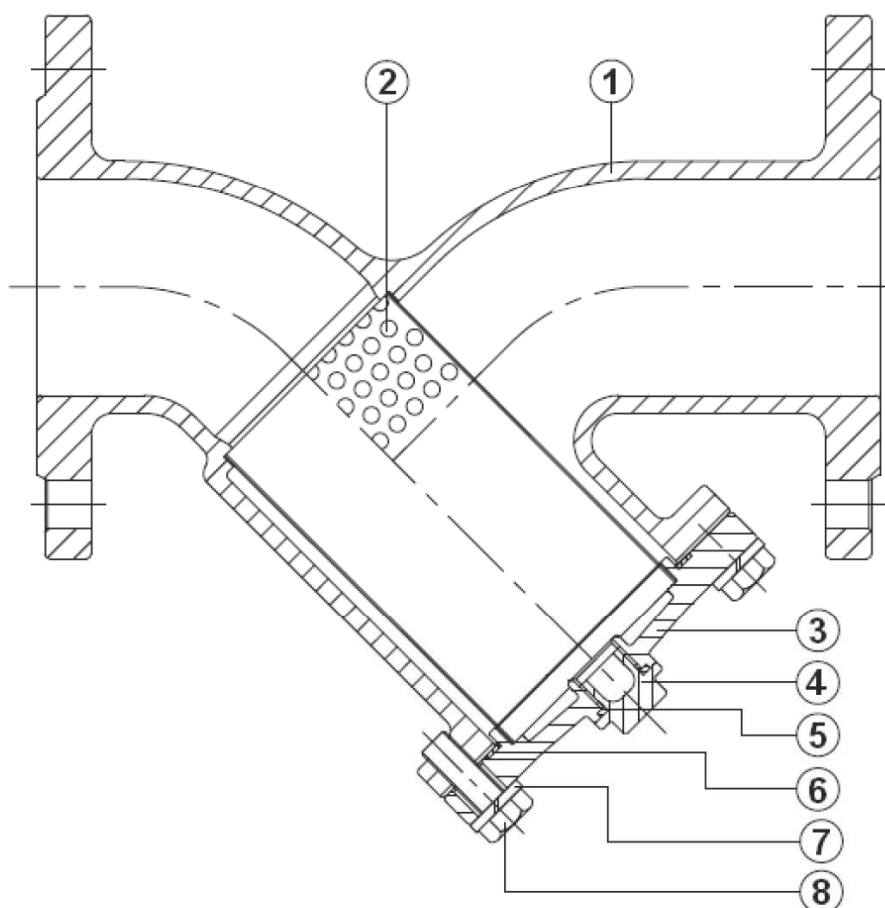

Item	Designation	Materials
1	Body	ASTM A351 CF8M
2	Filter	SS 304
3	Bonnet	ASTM A351 CF8M
4	Draining cap	ASTM A351 CF8M
5	Gasket	PTFE
6	Bonnet gasket	PTFE
7	Washer	SS 304
8	Screw	SS 304

FLANGED STAINLESS STEEL STRAINER PN16

SIZE (in mm) :

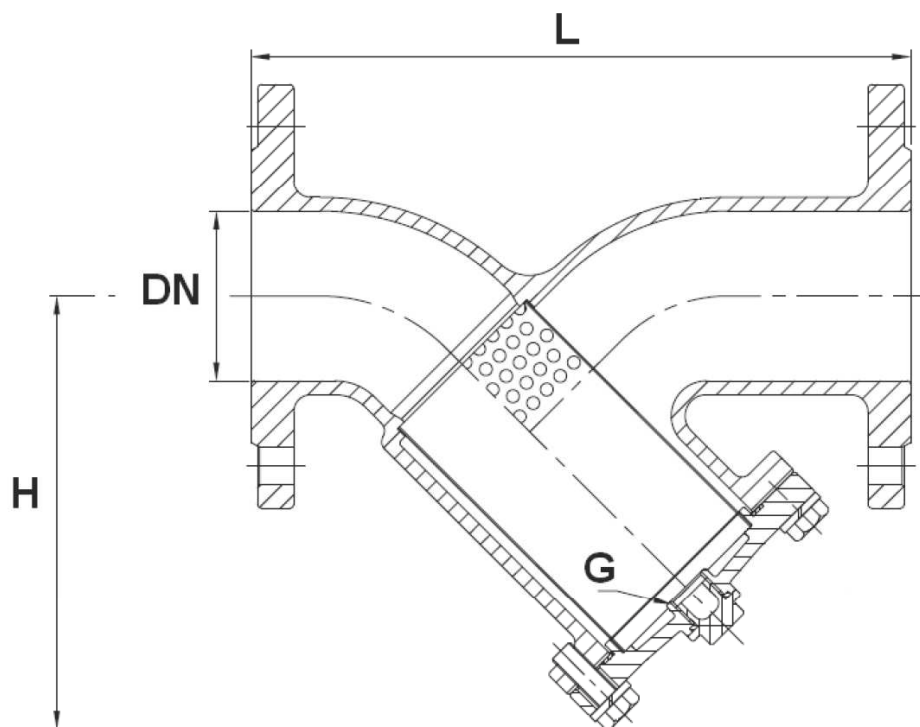

Filter size :

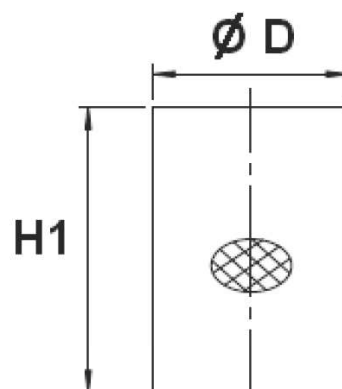

Ref.	DN	15	20	25	32	40	50	65	80	100	125	150	200	
240	L	130	150	160	180	200	230	290	310	350	400	480	600	
	H	85	85	112	114	132	150	185	200	232	274	328	410	
	G (drain)	1/2"	1/2"	1/2"	1/2"	1/2"	1/2"	1/2"	1/2"	3/4"	3/4"	3/4"	3/4"	
	Ø D	19	24	27	40	43	54	65	85	103	128	154	208	
	H1	57	55	87	82	99.5	102	135	150	160	221	250	300	
	Mesh	0.8	0.8	0.8	0.8	0.8	0.8	0.8	1	1	3	3	3	3
	Weight (Kg)	2	2.7	3.5	5	6.1	8.1	12.3	15.5	22	30	45.1	77.1	

FLANGED STAINLESS STEEL STRAINER PN16

STANDARDS :

- Fabrication according to ISO 9001 : 2008
- DIRECTIVE 97/23/CE : CE N° 0035
Risk category III Module H
- Construction according to EN 12516-1
- Tests according to API 598
- Length according to EN 558 series1 (DIN 3202 F1 – NF 29354)
- ISO PN16 Flanges R.F. according to EN 1092-1
- ATEX Group II Category 2 G/2D Zone 1 & 21 Zone 2 & 22 (optional marking)

INSTALLATION POSITIONS :

Vertical position (descendand fluid)



Horizontal position

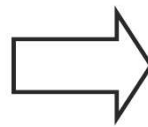

FLANGED STAINLESS STEEL STRAINER PN16

INSTALLATION INSTRUCTIONS

GENERAL GUIDELINES :

- Ensure that the strainers to be used are appropriate for the conditions of the installation (type of fluid, pressure and temperature).
- Be sure to have enough valves to be able to isolate the sections of piping as well as the appropriate equipment for maintenance and repair.
- Ensure that the strainers to be installed are of correct strength to be able to support the capacity of their usage.
- **Installation of all circuits should ensure that their function can be automatically tested on a regular basis (at least two times a year).**

INSTALLATION INSTRUCTIONS :

- **Before installing the strainers, clean and remove any objects from the pipes** (in particular bits of sealing and metal) which could obstruct and block the strainers.
- **Ensure that both connecting pipes either side of the strainer (upstream and downstream) are aligned** (if they're not, the strainer may not work correctly).
- **Make sure that the two sections of the pipe (upstream and downstream) match, the strainer unit will not absorb any gaps. Any distortions in the pipes may affect the tightness of the connection, the working of the strainer and can even cause a rupture.** To be sure, place the kit in position to ensure the assembling will work.
- Make sure flanges are cleaned.
- **If sections of piping do not have their final support in place, they should be temporarily fixed. This is to avoid unnecessary strain on the strainer.**
- Tighten the bolts in cross.
- The pressurisation must be increased gradually.
- So that the maintenance operations could be easily done, place a stop valve before and after the strainer. Thereby, the strainer could be isolated. During this operation, ensure to have a new bonnet gasket to avoid a leakage during the restarting.
- **Fluids in the strainer must not contain solid objects (it could damaged the seat).**